



New

Chamfer angle

15° 30°
45° 60°

Back & Front Chamfer Tool

Features

- All applications for Chamfer
: Back Chamfering, Front Chamfering, De-burring, Counter sinking
- Chamfer angle 15°, 30°, 45°, 60° for various customer's needs.
- The long cutting edge provides a wide chamfering range which reduces the number of tools.



Back & Front Chamfer Tools



Long Chamfer Tools



Back & Front Chamfer Tool

Code system | Insert

Code system

CEA	45	11	100	R	S	075
Chamfer endmill	Chamfer angle	Available insert	Min. machined diameter (ø1inch)	Hand of tool	Tool length	Shank diameter
		11 : SPMT110408-KC 12 : SPMN120308 31 : XCET310404ER-KC		- R : Right - L : Left	- S : Standard - M : Middle - L : Long	- 0.75inch

Insert

Back & Front Chamfer Type

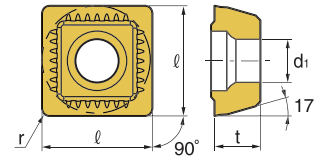
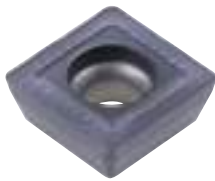

Designation	l	t	r	d ₁	Coated				Uncoated	
					PC230	PC3525	PC3545	PC6510	G10	ST30A
SPMT110408-KC	0.433	3/16	1/32	0.177	●	○	○	○	●	●

● Stock item, ○ Under preparing for stock

Front Chamfer Type

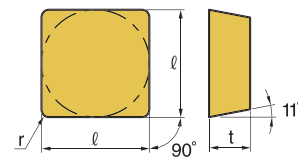
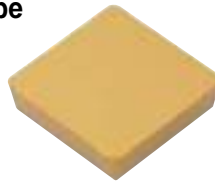

Designation	l	t	r	Coated		Uncoated
				NCM325	PC3525	ST30A
SPMN120308	1/2	1/8	1/32	○	○	●

● Stock item, ○ Under preparing for stock

Long Chamfer Type

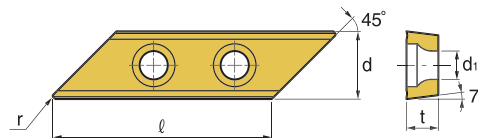

Designation	l	d	t	r	d ₁	Coated				Uncoated	
						PC230	PC3525	PC3545	PC6510	G10	ST30A
XCET310404ER-KC	1.217	0.375	3/16	1/64	4.4	●	○	○	○	●	●

● Stock item, ○ Under preparing for stock



Back & Front Chamfer Tool

Holder

Holder

Back & Front Chamfer Type

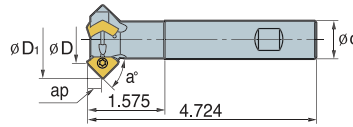

Fig.1

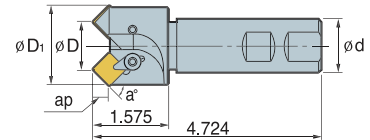
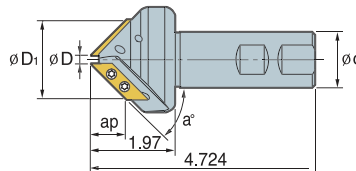

Fig.2

Designation	Available Insert	Chamfer angle (a°)		ϕD	ϕD_1	ϕd	a_p	No. of tooth	Available diameter Min.- Max.	Applications
		Front	Back							
CEA 15-11100R-S075	SPMT110408-KC	15°	-	1.000	1.217	0.75	0.374	2	$\phi 1.00\sim\phi 1.18$	Front chamfering
CEA 30-11100R-S075		30°	60°	1.000	1.413	0.75	0.335	2	$\phi 1.00\sim\phi 1.37$	Back,Front chamfering
CEA 45-11100R-S075		45°	-	0.281	0.868	0.75	0.276	1	$\phi 0.28\sim\phi 0.82$	Front chamfering
CEA 45-11075R-S075		45°	45°	0.750	1.337	0.75	0.276	2	$\phi 0.75\sim\phi 1.29$	Back,Front chamfering
CEA 45-11100R-S075		45°	45°	1.000	1.587	0.75	0.276	3	$\phi 1.00\sim\phi 1.53$	Back,Front chamfering
CEA 60-11100R-S075		60°	30°	1.000	1.720	1.25	0.197	3	$\phi 1.00\sim\phi 1.65$	Back,Front chamfering
CEA 45-12028R-S125	SPMN120308	45°	-	0.281	0.923	1.25	0.307	1	$\phi 0.28\sim\phi 0.86$	Front chamfering
CEA 45-12075R-S125		45°	-	0.750	1.431	1.25	0.307	2	$\phi 0.75\sim\phi 1.41$	Front chamfering
CEA 45-12100R-S125		45°	-	1.000	1.681	1.25	0.307	2	$\phi 1.00\sim\phi 1.61$	Front chamfering
CEA 45-12137R-S125		45°	-	1.375	2.056	1.25	0.307	2	$\phi 1.37\sim\phi 2.00$	Front chamfering

Long Chamfer Type





Designation	Available Insert	Chamfer angle (a°)		ϕD	ϕD_1	ϕd	a_p	No. of tooth	Available diameter Min.- Max.	Applications
		Front	Back							
CEA 30-31020R-S125	XCET310404ER-KC	30°	-	0.203	1.384	1.25	1.039	1	$\phi 0.20\sim\phi 1.37$	Front chamfering
CEA 45-31020R-S125		45°	-	0.203	1.896	1.25	0.846	2	$\phi 0.20\sim\phi 1.89$	Front chamfering
CEA 60-31020R-S125		60°	-	0.203	2.278	1.25	0.598	2	$\phi 0.20\sim\phi 2.27$	Front chamfering



Back & Front Chamfer Tool

Parts | Recommended cutting condition | Application examples

Parts

Designation				
CEA00 - 11 000R - S000	FTKA0408	-	-	TW15S
CEA00 - 12 000R - S000	CHX0617L	CH6R2	CR05	HW30L
CEA00 - 31 000R - S000	FTKA03510	-	-	TW15S

Recommended cutting condition

ISO	Chamfering		Face chamfering		Grade
	vc (sfm)	fz (ipt)	vc (sfm)	fz (ipt)	
P	350~550	0.008~0.019	350~550	0.002~0.02	PC230 PC3525 PC3545 ST30A
M	300~400	0.004~0.012	300~400	0.002~0.006	PC3545
K	350~550	0.008~0.024	350~550	0.002~0.02	PC6510 G10

Application examples

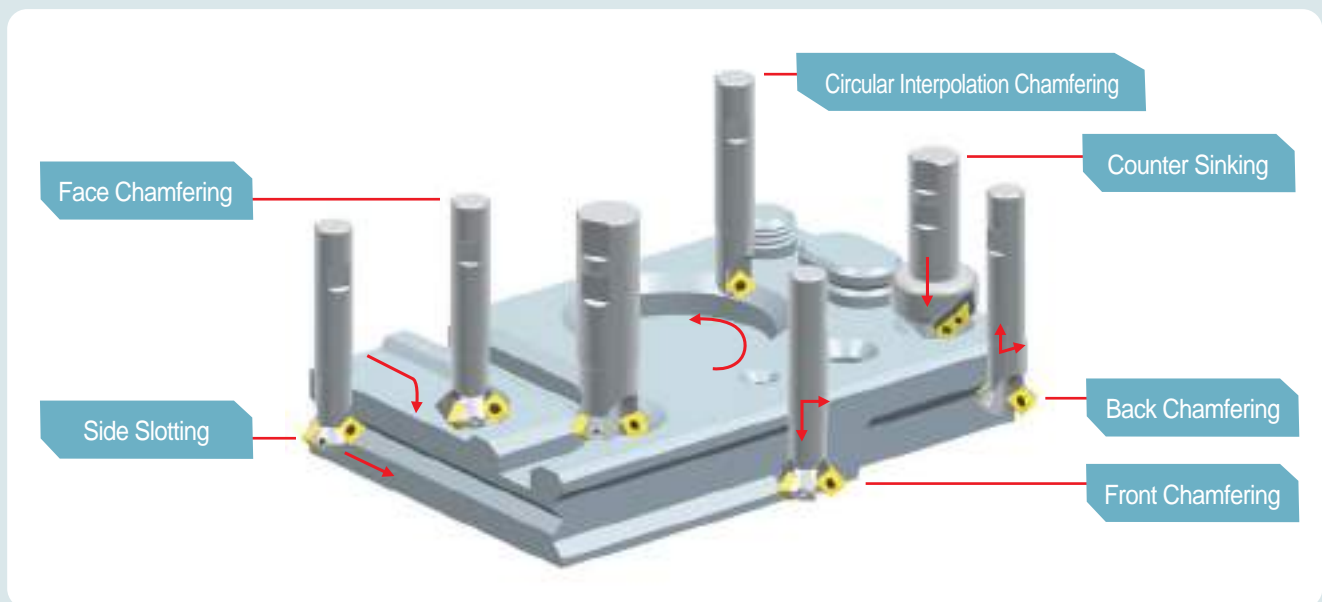

KORLOY AMERICA Inc.

2750 Oregon Court, South Bay Business Park, Suite M7, Torrance, CA90503, USA
 TEL:+1 310 782 3800 TOLL FREE:+1 888 711 0001 FAX:+1 310 782 3885
 E-MAIL: KorloyAmerica@korloy.com WEB: www.KorloyAmerica.com

KORLOY Inc.

Holystar B/D 953-1, Doksanbon-Dong, Geumcheon-Gu, Seoul, Korea
 TEL:+82 2 522 3181 FAX:+82 2 522 3184, +82 2 3474 4744
 E-MAIL: export@korloy.com WEB: www.korloy.com