

**ISO 26623-1**

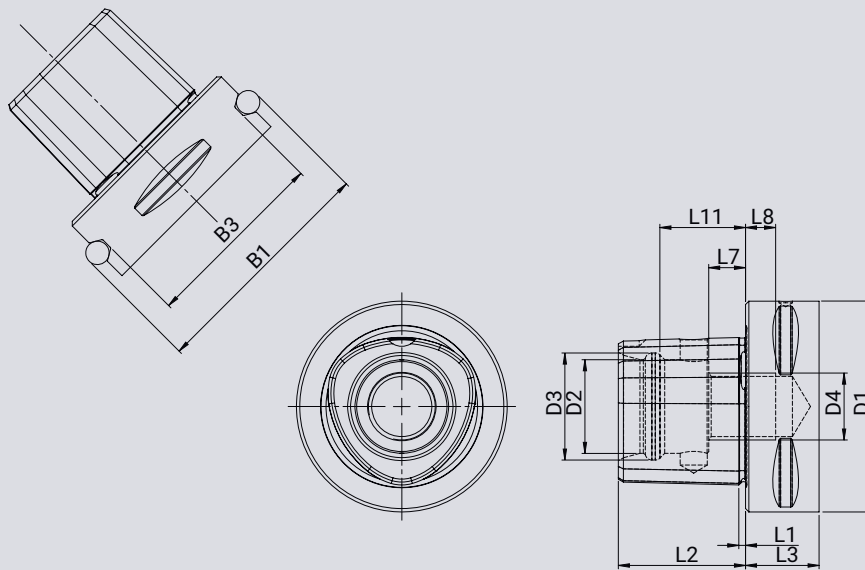



ATTACCO SIZE	B1	B3	D1	D2	D3	D4	L1	L2	L3	L7	L8	L11
32	39	27,9	32	15	16,5	M12 X 1,5P	2,5	19	15	6	6	13,5
40	46	34,9	40	18	20	M14 X 1,5P	2,5	24	20	9	6	17,5
50	59,3	44	50	21	24	M16 X 1,5P	3	30	20	10	7	22
63	70,7	55,4	63	28	32	M20 X 2,0P	3	38	22	11	9	26
80	86	70,7	80	32	38	M20 X 2,0P	3	48	30	20	0	34

Tutti i mandrini portautensili PAGNONI TOOLS vengono prodotti secondo le normative DIN  
 All PAGNONI TOOLS toolholders are manufactured according to DIN norms  
 Alle PAGNONI TOOLS Aufnahme sind nach DIN Norm produziert  
 Tous les mandrins porte-outils PAGNONI TOOLS sont produits suivant les specifications DIN

## DATI TECNICI

### PRE-BILANCIATI:

- Grado di equilibratura aggiuntiva G 6,3 8000

### MATERIALI E TRATTAMENTI:

- Acciaio da cementazione legato
- Temprati-rinvenuti
- HRC 58  $\pm$ 2 – profondità si indurimento 0,4-0,5 mm
- Resistenza 800-1000 N/mm<sup>2</sup>
- Bruniti dopo trattamento termico
- Rettificati internamente e esternamente

## TECHNISCHE DATEN

### VORGEWUCHTET:

- Wuchtgüte angegeben G 6,3 8000

### WERKSTOFF UND OBERFLÄCHENBEHANDLUNGEN:

- Legierter Einsatzstahl
- Gehärtet und angelassen
- Einsatzgehärtet HRC 58  $\pm$  2, Härtetiefe 0,4-0,5 mm
- Festigkeit 800-1000 N/mm<sup>2</sup>
- Brüniert nach wärmebehandlung
- Innen- und Außengeschliffen

## TECHNICAL FEATURES

### PRE-BALANCED:

- Additional balancing grade G 6,3 8000

### MATERIAL AND SURFACE TREATMENTS:

- Alloyed case-hardened steel
- Hardened-tempered
- Case hardened HRC 58  $\pm$  2 - hardening depth 0,4-0,5 mm
- Strength 800-1000 N/mm<sup>2</sup>
- Black-finished after hardened
- Internal and external grinding

## DONNE TECHNIQUES

### PRÉ-ÉQUILIBRÉ:

- Équilibrage attitionnel G 6,3 8000

### MATÉRIAUX ET TRAITEMENTS:

- Acier de cémentation allié
- Temprés – Revenus
- Cémentation à HRC 58  $\pm$  2, profondeur de cémentation 0,4-0,5 mm
- Résistance 800-1000 N/mm<sup>2</sup>
- Bruni après traitement thermique
- Rectifié en interne et en externe



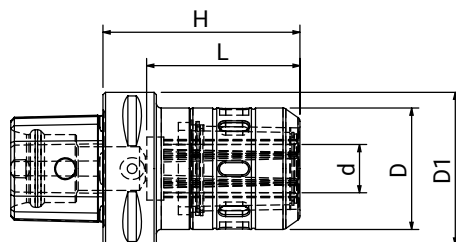

COD	CONO	d	H	L	D	D1
XP3FS112	C30	12	65	47	34	30
XP3FS116	C30	16	60	51	42	30
XP4FS112	C40	12	65	47	34	40
XP4FS116	C40	16	65	51	42	40
XP4FS120	C40	20	90	62	54	40
XP5FS112	C50	12	80	47	34	50
XP5FS116	C50	16	70	51	42	50
XP5FS120	C50	20	70	60	54	50
XP5FS132	C50	32	95	80	63	50
XP6FS112	C63	12	100	80	34	63
XP6FS116	C63	16	100	80	42	63
XP6FS120	C63	20	100	80	54	63
XP6FS132	C63	32	100	80	72	63
XP8FS020	C80	20	75	80	54	80
XP8FS032	C80	32	95	80	72	80

ISO 26623-1

ACCESSORI | ACCESSORIES | ZUBEHÖR | ACCESSOIRES



> PAG. 259

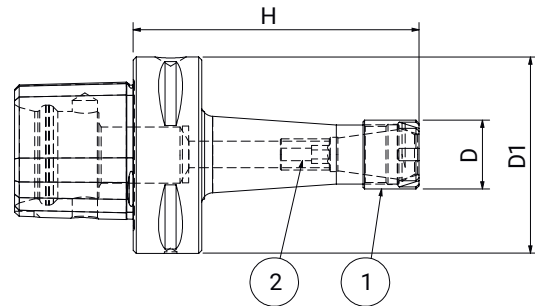

COD	CONO	TIPOLOGIA	H	D	D1	1 - GHIERA	2 - GRANO INTERNO
XP3PM107	C32	ER11MINI	50	16	32	911GHRMN	-
XP3PM110	C32	ER16MINI	50	22	32	916GHRMN	-
XP3PM113	C32	ER20MINI	50	28	32	920GHRMN	-
XP3PM116	C32	ER25MINI	50	35	32	925GHRMN	-
XP4PM107	C40	ER11MINI	60	16	40	911GHRMN	-
XP4PM110	C40	ER16MINI	60	22	40	916GHRMN	-
XP4PM113	C40	ER20MINI	60	28	40	920GHRMN	-
XP4PM116	C40	ER25MINI	60	35	40	925GHRMN	-
XP5PM107	C50	ER11MINI	60	16	50	911GHRMN	100601001
XP5PM110	C50	ER16MINI	60	22	50	916GHRMN	101001601
XP5PM113	C50	ER20MINI	60	28	50	920GHRMN	101001601
XP5PM116	C50	ER25MINI	60	35	50	925GHRMN	101815801
XP5PM207	C50	ER11MINI	100	16	50	911GHRMN	100601001
XP5PM210	C50	ER16MINI	100	22	50	916GHRMN	101001601
XP5PM213	C50	ER20MINI	100	28	50	920GHRMN	101001601
XP5PM216	C50	ER25MINI	100	35	50	925GHRMN	101815801
XP5PM407	C50	ER11MINI	160	16	50	911GHRMN	100601001
XP5PM410	C50	ER16MINI	160	22	50	916GHRMN	101001601
XP5PM413	C50	ER20MINI	160	28	50	920GHRMN	101001601
XP5PM416	C50	ER25MINI	160	35	50	925GHRMN	101815801
XP6PM107	C63	ER11MINI	60	16	63	911GHRMN	100601001
XP6PM110	C63	ER16MINI	60	22	63	916GHRMN	101001601
XP6PM113	C63	ER20MINI	60	28	63	920GHRMN	101001601
XP6PM116	C63	ER25MINI	60	35	63	925GHRMN	101815801
XP6PM207	C63	ER11MINI	100	16	63	911GHRMN	100601001
XP6PM210	C63	ER16MINI	100	22	63	916GHRMN	101001601
XP6PM213	C63	ER20MINI	100	28	63	920GHRMN	101001601
XP6PM216	C63	ER25MINI	100	35	63	925GHRMN	101815801
XP6PM407	C63	ER11MINI	160	16	63	911GHRMN	100601001
XP6PM410	C63	ER16MINI	160	22	63	916GHRMN	101001601
XP6PM413	C63	ER20MINI	160	28	63	920GHRMN	101001601
XP6PM416	C63	ER25MINI	160	35	63	925GHRMN	101815801

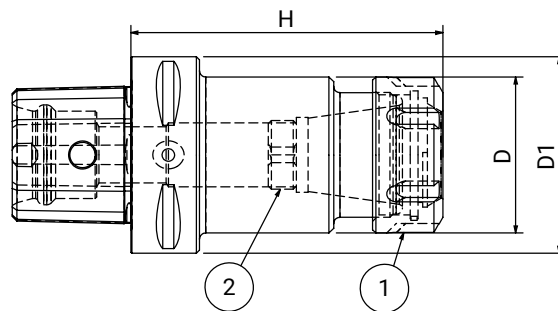

COD	CONO	TIPOLOGIA	H	D	D1	1 - GHIERA	2 - GRANO INTERNO
XP3PP110	C32	ER16	45	32	32	916GHREQ	101001601
XP3PP113	C32	ER20	45	34	32	920GHREQ	101001601
XP3PP116	C32	ER25	52	42	32	925GHREQ	101815801
XP4PP110	C40	ER16	70	32	40	916GHREQ	101001601
XP4PP113	C40	ER20	52	35	40	920GHREQ	101001601
XP4PP116	C40	ER25	52	42	40	925GHREQ	101815801
XP4PP120	C40	ER32	54	50	40	932GHREQ	102215901
XP5PP110	C50	ER16	60	32	50	916GHREQ	101001601
XP5PP113	C50	ER20	60	35	50	920GHREQ	101001601
XP5PP116	C50	ER25	60	42	50	925GHREQ	101815801
XP5PP120	C50	ER32	60	50	50	932GHREQ	102215901
XP5PP126	C50	ER40	65	63	50	940GHREQ	103015901
XP5PP210	C50	ER16	100	32	50	916GHREQ	101001601
XP5PP213	C50	ER20	100	34	50	920GHREQ	101001601
XP5PP216	C50	ER25	100	42	50	925GHREQ	101815801
XP5PP220	C50	ER32	100	50	50	932GHREQ	102215901
XP5PP226	C50	ER40	100	63	50	940GHREQ	103015901
XP6PP110	C63	ER16	60	32	63	916GHREQ	101001601
XP6PP113	C63	ER20	60	35	63	920GHREQ	101001601
XP6PP116	C63	ER25	60	42	63	925GHREQ	101815801
XP6PP120	C63	ER32	60	50	63	932GHREQ	102215901
XP6PP126	C63	ER40	70	63	63	940GHREQ	103015901
XP6PP210	C63	ER16	100	32	63	916GHREQ	101001601
XP6PP213	C63	ER20	100	35	63	920GHREQ	101001601
XP6PP216	C63	ER25	100	42	63	925GHREQ	101815801
XP6PP220	C63	ER32	100	50	63	932GHREQ	102215901
XP6PP226	C63	ER40	100	63	63	940GHREQ	103015901
XP6PP410	C63	ER16	160	32	63	916GHREQ	101001601
XP6PP416	C63	ER25	160	42	63	925GHREQ	101815801
XP6PP420	C63	ER32	160	50	63	932GHREQ	102215901
XP6PP426	C63	ER40	160	63	63	940GHREQ	103015901
XP8PP116	C80	ER25	70	42	80	925GHREQ	101815801
XP8PP120	C80	ER32	70	50	80	932GHREQ	102215901
XP8PP126	C80	ER40	70	63	80	940GHREQ	103015901

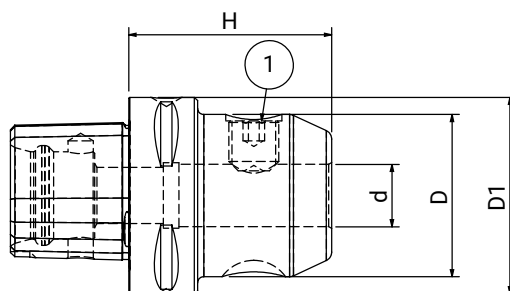

COD	CONO	d	H	D	D1	1 - GRANO
XP3WLD06	C32	6	46	25	32	1 x 100601002
XP3WLD08	C32	8	46	28	32	1 x 100801002
XP3WLD10	C32	10	50	35	32	1 x 101001202
XP3WLD12	C32	12	55	42	32	1 x 101201602
XP4WLD06	C40	6	50	25	40	1 x 100601002
XP4WLD08	C40	8	50	28	40	1 x 100801002
XP4WLD10	C40	10	50	35	40	1 x 101001202
XP4WLD12	C40	12	55	42	40	1 x 101201602
XP4WLD14	C40	14	55	44	40	1 x 101201602
XP4WLD16	C40	16	55	48	40	1 x 101401602
XP5WLD06	C50	6	55	25	50	1 x 100601002
XP5WLD08	C50	8	55	28	50	1 x 100801002
XP5WLD10	C50	10	65	35	50	1 x 101001202
XP5WLD12	C50	12	65	42	50	1 x 101201602
XP5WLD14	C50	14	65	44	50	1 x 101201602
XP5WLD16	C50	16	65	48	50	1 x 101401602
XP5WLD18	C50	18	65	50	50	1 x 101401602
XP5WLD20	C50	20	65	52	50	1 x 101601602
XP5WLD25	C50	25	80	63	50	2 x 101802002
XP6WLD06	C63	6	55	25	63	1 x 100601002
XP6WLD08	C63	8	55	28	63	1 x 100801002
XP6WLD10	C63	10	60	35	63	1 x 101001202
XP6WLD12	C63	12	60	42	63	1 x 101201602
XP6WLD14	C63	14	60	44	63	1 x 101201602
XP6WLD16	C63	16	65	48	63	1 x 101401602
XP6WLD20	C63	20	65	52	63	1 x 101601602
XP6WLD25	C63	25	80	63	63	2 x 101802002
XP6WLD32	C63	32	90	72	63	2 x 102002002
XP8WLD06	C80	6	70	25	80	1 x 100601002
XP8WLD08	C80	8	70	28	80	1 x 100801002
XP8WLD10	C80	10	70	35	80	1 x 101001202
XP8WLD12	C80	12	70	42	80	1 x 101201602
XP8WLD14	C80	14	70	44	80	1 x 101201602
XP8WLD16	C80	16	70	48	80	1 x 101401602
XP8WLD20	C80	20	70	50	80	1 x 101601602
XP8WLD25	C80	25	80	52	80	1 x 101801202
XP8WLD32	C80	32	80	72	80	1 x 102002002
XP8WLD40	C80	40	110	80	80	1 x 101801202



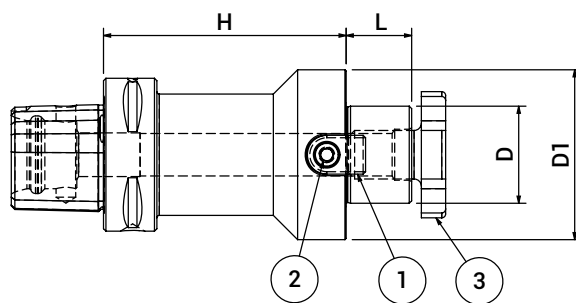

COD	CONO	D	H	D1	L	1 - TASSELLO	2 - VITE	1 - VITE A CROCE
XP3PF016	C32	16	32	32	17	2 x 916TSL03	2 x 110300801	916VTC02
XP4PF016	C40	16	32	32	17	2 x 916TSL03	2 x 110300801	916VTC02
XP4PF116	C40	16	55	38	17	2 x 916TSL03	2 x 110300801	916VTC02
XP4PF022	C40	22	25	40	19	2 x 922TSL10	2 x 110401201	922VTC02
XP4PF122	C40	22	55	48	19	2 x 922TSL10	2 x 110401201	922VTC02
XP5PF116	C50	16	60	38	17	2 x 916TSL11	2 x 110301201	916VTC02
XP5PF016	C50	16	35	38	17	2 x 916TSL11	2 x 110301201	916VTC02
XP5PF122	C50	22	60	48	19	2 x 922TSL11	2 x 110401201	922VTC02
XP5PF022	C50	22	25	48	19	2 x 922TSL11	2 x 110401201	922VTC02
XP5PF127	C50	27	60	58	21	2 x 927TSL11	2 x 110501601	927VTC02
XP5PF132	C50	32	60	63	24	2 x 932TSL10	2 x 110601201	932VTC02
XP6PF016	C63	16	40	32	17	2 x 916TSL10	2 x 110300801	916VTC02
XP6PF116	C63	16	63	38	17	2 x 916TSL11	2 x 110301201	916VTC02
XP6PF022	C63	22	25	55	19	2 x 922TSL11	2 x 110401201	922VTC02
XP6PF222	C63	22	100	48	19	2 x 922TSL11	2 x 110401201	922VTC02
XP6PF027	C63	27	25	63	21	2 x 927TSL02	2 x 110401201	927VTC02
XP6PF227	C63	27	100	58	21	2 x 927TSL11	2 x 110501601	927VTC02
XP6PF032	C63	32	25	63	24	2 x 932TSL20	2 x 110601601	932VTC02
XP6PF232	C63	32	100	63	24	2 x 932TSL11	2 x 110601601	932VTC02
XP6PF040	C63	40	40	89	27	2 x 940TSL10	2 x 110601601	940VTC02
XP6PF240	C63	40	100	70	27	2 x 940TSL10	2 x 110602001	940VTC02
XP8PF116	C80	16	50	32	17	2 x 916TSL10	2 x 110301001	916VTC02
XP8PF022	C80	22	30	55	19	2 x 922TSL13	2 x 110401601	922VTC02
XP8PF027	C80	27	30	65	21	2 x 927TSL11	2 x 110501601	927VTC02
XP8PF032	C80	32	30	79	24	2 x 932TSL12	2 x 110602001	932VTC02
XP8PF040	C80	40	30	80	27	2 x 940TSL05	2 x 110601601	940VTC02

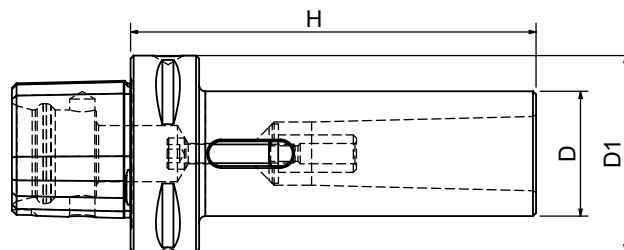

ISO 26623-1

COD	CONO	MORSE	D	H	D1
XP4MP102	C40	2	32	110	40
XP4MP103	C40	3	40	130	40
XP5MP102	C50	2	32	110	50
XP5MP103	C50	3	40	130	50
XP6MP102	C63	2	32	110	63
XP6MP103	C63	3	40	130	63
XP6MP104	C63	4	52	155	63
XP8MP103	C80	3	40	140	80
XP8MP104	C80	4	52	170	80
XP8MP105	C80	5	63	200	80

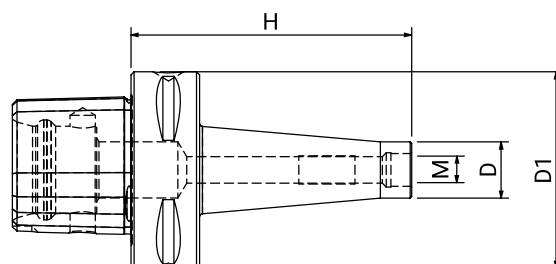

COD	CONO	M	H	D	D1
XP5AF108	C50	M8	70	13	50
XP5AF110	C50	M10	80	18	50
XP5AF112	C50	M12	80	21	50
XP5AF116	C50	M16	80	29	50
XP6AF108	C63	M8	70	13	63
XP6AF110	C63	M10	90	18	63
XP6AF112	C63	M12	100	21	63
XP6AF116	C63	M16	100	29	63

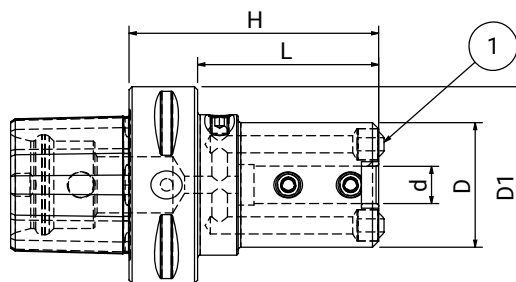

COD	CONO	d	D	H	L	D1	1 - OGIVA
XP3BR006	C32	06	36	35	20	32	2 x OGIVA08
XP3BR008	C32	08	36	35	20	32	2 x OGIVA08
XP3BR010	C32	10	36	35	20	32	2 x OGIVA08
XP3BR012	C32	12	36	40	24	32	2 x OGIVA08
XP3BR016	C32	16	40	50	42	32	2 x OGIVA08
XP4BR108	C40	08	36	40	19	40	2 x OGIVA08
XP4BR110	C40	10	36	40	19	40	2 x OGIVA08
XP4BR112	C40	12	36	45	24	40	2 x OGIVA08
XP4BR116	C40	16	40	50	29	40	2 x OGIVA08
XP4BR120	C40	20	45	70	42	40	2 x OGIVA08
XP4BR125	C40	25	54	70	42	40	2 x OGIVA08
XP5BR108	C50	08	40	50	25	50	2 x OGIVA10
XP5BR110	C50	10	45	50	25	50	2 x OGIVA10
XP5BR112	C50	12	36	70	45	50	2 x OGIVA10
XP5BR116	C50	16	40	80	48	50	2 x OGIVA10
XP5BR120	C50	20	45	80	48	50	2 x OGIVA10
XP5BR125	C50	25	54	80	50	50	2 x OGIVA10
XP6BR108	C63	08	36	60	35	63	2 x OGIVA10
XP6BR110	C63	10	36	60	35	63	2 x OGIVA10
XP6BR112	C63	12	36	60	35	63	2 x OGIVA10
XP6BR116	C63	16	40	80	48	63	2 x OGIVA10
XP6BR120	C63	20	45	80	48	63	2 x OGIVA10
XP6BR125	C63	25	63	85	52	63	2 x OGIVA10
XP6BR132	C63	32	72	95	58	63	2 x OGIVA12
XP6BR140	C63	40	80	105	72	63	2 x OGIVA12
XP8BR116	C80	16	45	85	48	80	2 x OGIVA10
XP8BR120	C80	20	50	85	48	80	2 x OGIVA10
XP8BR125	C80	25	55	85	48	80	2 x OGIVA10
XP8BR132	C80	32	72	95	58	80	2 x OGIVA12
XP8BR140	C80	40	80	110	73	80	2 x OGIVA12
XP8BR150	C80	50	85	100	73	80	2 x OGIVA12

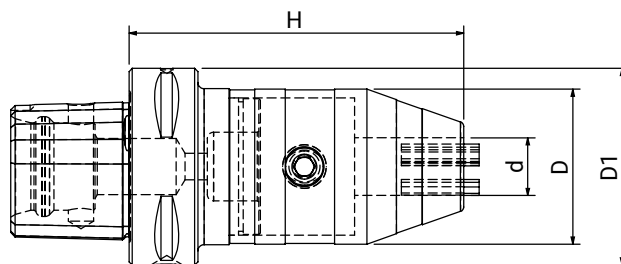

COD	CONO	d	D	H	D1
XP3MAZ13	C30	1-13	50	99	32
XP4MAZ13	C40	1-13	50	115	40
XP5MAZ13	C50	1-13	50	98	50
XP6MAZ13	C63	1-13	50	105	63
XP6MAZ16	C63	3-16	50	110	63
XP8MAZ13	C80	1-13	50	109	80
XP8MAZ16	C63	3-16	50	114	80

ISO 26623-1

ACCESSORI | ACCESSORIES | ZUBEHÖR | ACCESSOIRES



> PAG. 279

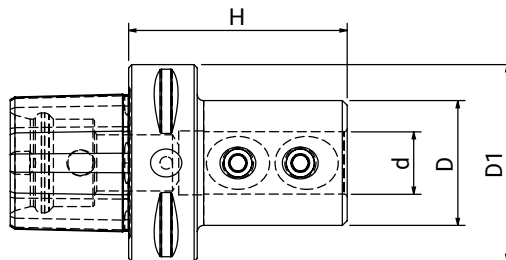

ISO 26623-1

COD	CONO	d	H	D	D1
XP3PB116	C32	16	56	36	32
XP3PB120	C32	20	60	40	32
XP4PB108	C40	8	50	28	40
XP4PB110	C40	10	50	35	40
XP4PB112	C40	12	50	42	40
XP4PB116	C40	16	56	36	40
XP4PB120	C40	20	60	40	40
XP4PB125	C40	25	77	45	40
XP5PB108	C50	8	52	28	50
XP5PB110	C50	10	52	38	50
XP5PB112	C50	12	52	42	50
XP5PB116	C50	16	65	36	50
XP5PB120	C50	20	60	40	50
XP5PB125	C50	25	70	45	50
XP5PB132	C50	32	75	52	50
XP6PB108	C63	8	60	28	63
XP6PB110	C63	10	60	35	63
XP6PB112	C63	12	60	42	63
XP6PB116	C63	16	70	36	63
XP6PB120	C63	20	70	40	63
XP6PB125	C63	25	72	45	63
XP6PB132	C63	32	75	52	63
XP6PB140	C63	40	85	63	63
XP8PB116	C80	16	80	36	80
XP8PB120	C80	20	80	40	80
XP8PB125	C80	25	85	45	80
XP8PB132	C80	32	90	52	80
XP8PB140	C80	40	95	63	80

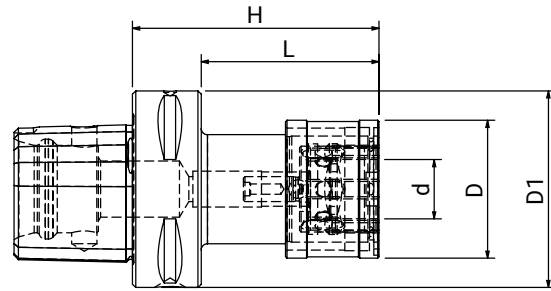

COD	CONO	RANGE	SIZE	d	D	H	L	D1
XP4PCRM1	C40	M3-M12	GR.1	19	39,2	73	53	40
XP4PCRM2	C40	M6-M20	GR.2	31	54,5	116,5	96,5	40
XP5PCRM1	C50	M3-M12	GR.1	19	39,2	91	71	50
XP5PCRM2	C50	M6-M20	GR.2	31	54,5	122	144	50
XP6PCRM1	C63	M3-M12	GR.1	19	39,2	90	68	63
XP6PCRM2	C63	M6-M20	GR.2	31	54,5	143	121	63
XP8PCRM1	C80	M3-M12	GR.1	19	39,2	80	50	80
XP8PCRM2	C80	M6-M20	GR.2	31	54,5	118,5	88,5	80

ISO 26623-1

ACCESSORI | ACCESSORIES | ZUBEHÖR | ACCESSOIRES



> PAG. 258



> PAG. 257

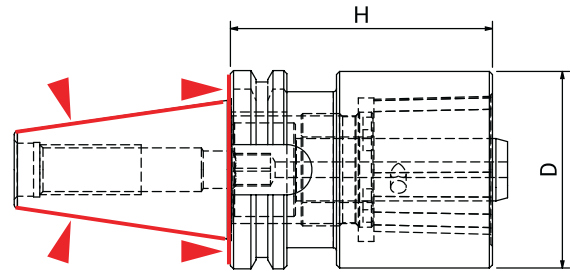

ISO 26623-1

COD	CONO	RIDUZIONE	D	H
141XP0C3	ISO40	C32	32	30
141XP0C4	ISO40	C40	40	30
141XP0C5	ISO40	C50	50	40
141XP0C6	ISO40	C63	63	85
151XP0C3	ISO50	C32	32	30
151XP0C4	ISO50	C40	40	30
151XP0C5	ISO50	C50	50	30
151XP0C6	ISO50	C63	63	30
151XP0C8	ISO50	C80	80	70
151XP1C3	ISO50	C32	32	60
151XP1C4	ISO50	C40	40	60
151XP1C5	ISO50	C50	50	70
151XP1C6	ISO50	C63	63	50
151XP1C8	ISO50	C80	80	120
151XP2C6	ISO50	C63	63	100



RIDUZIONI MAS 403 BT A DOPPIO CONTATTO PER ATTACCO POLIGONALE  
 REDUCTION DUAL CONTACT MAS 403 BT WITH POLYGONAL SHANK  
 REDUKTION DOPPELKONTAKT MAS 403 BT MIT POLYGONALSHAFT  
 REDUCTION CONTACT DIRECT MAS 403 BT AVEC ATTACHEMENT POLYGONALE

DOPPIO CONTATTO  
 MAS 403 BT

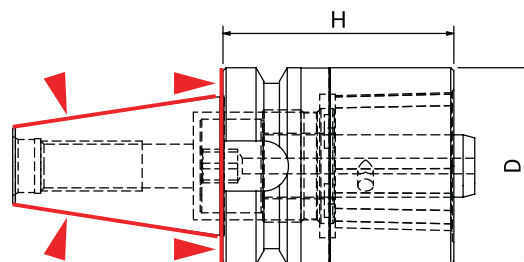

COD	CONO	RIDUZIONE	D	H
341XP0C3	ISO40	C32	32	30
341XP0C4	ISO40	C40	40	30
341XP0C5	ISO40	C50	50	40
341XP0C6	ISO40	C63	63	75
351XP0C3	ISO50	C32	32	40
351XP0C4	ISO50	C40	40	40
351XP0C5	ISO50	C50	50	40
351XP0C6	ISO50	C63	63	50
351XP0C8	ISO50	C80	80	70
351XP1C3	ISO50	C32	32	70
351XP1C4	ISO50	C40	40	70
351XP1C5	ISO50	C50	50	70
351XP1C6	ISO50	C63	63	90
351XP1C8	ISO50	C80	80	120

ISO 26623-1

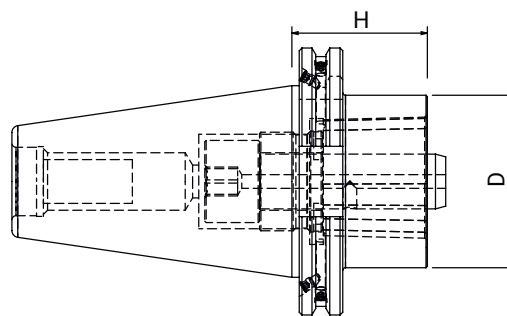

ISO 26623-1

COD	CONO	RIDUZIONE	D	H
140XP0C3	ISO40	C32	32	30
140XP0C4	ISO40	C40	40	30
140XP0C5	ISO40	C50	50	40
140XP0C6	ISO40	C63	63	85
140XP1C3	ISO40	C32	32	60
140XP1C4	ISO40	C40	40	60
150XP0C3	ISO50	C32	32	30
150XP0C4	ISO50	C40	40	30
150XP0C5	ISO50	C50	50	30
150XP0C6	ISO50	C63	63	30
150XP0C8	ISO50	C80	80	70
150XP1C3	ISO50	C32	32	60
150XP1C4	ISO50	C40	40	60
150XP1C5	ISO50	C50	50	70
150XP1C6	ISO50	C63	63	50
150XP1C8	ISO50	C80	80	120
150XP2C5	ISO50	C50	50	110
150XP2C6	ISO50	C63	63	80

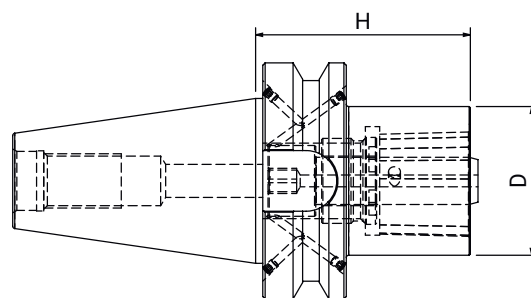

COD	CONO	RIDUZIONE	D	H
340XP0C3	ISO40	C32	32	30
340XP0C4	ISO40	C40	40	30
340XP0C5	ISO40	C50	50	50
340XP0C6	ISO40	C63	63	75
340XP1C3	ISO40	C32	32	60
340XP1C4	ISO40	C40	40	60
340XP1C5	ISO40	C50	50	90
350XP0C3	ISO50	C32	32	40
350XP0C4	ISO50	C40	40	40
350XP0C5	ISO50	C50	50	40
350XP0C6	ISO50	C63	63	50
350XP0C8	ISO50	C80	80	70
350XP1C3	ISO50	C32	32	70
350XP1C4	ISO50	C40	40	70
350XP1C5	ISO50	C50	50	80
350XP1C6	ISO50	C63	63	90
350XP1C8	ISO50	C80	80	120

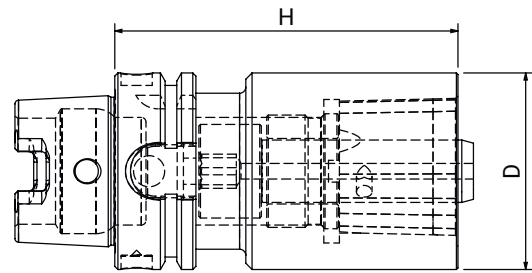

ISO 26623-1

COD	CONO	RIDUZIONE	D	D1	H
66AXP0C3	HSK63/A	C32	32	63	80
66AXP0C4	HSK63/A	C40	40	63	80
66AXP0C5	HSK63/A	C50	50	63	90
66AXP0C6	HSK63/A	C63	63	63	110
61AXP0C3	HSK100/A	C32	32	100	80
61AXP0C4	HSK100/A	C40	40	100	90
61AXP0C5	HSK100/A	C50	50	100	100
61AXP0C6	HSK100/A	C63	63	100	90
61AXP0C8	HSK100/A	C80	80	100	130
61AXP1C6	HSK100/A	C63	63	100	150

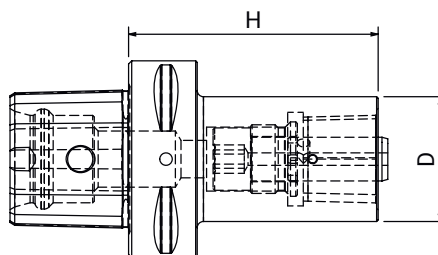

COD	CONO	RIDUZIONE	D	D1	H
XP4XP0C3	C40	C32	32	40	55
XP5XP0C4	C50	C40	40	50	65
XP5XP1C4	C50	C40	40	50	85
XP6XP0C4	C63	C40	40	63	80
XP6XP0C5	C63	C50	50	63	80
XP8XP0C5	C80	C50	50	80	120
XP8XP0C6	C80	C63	63	80	110

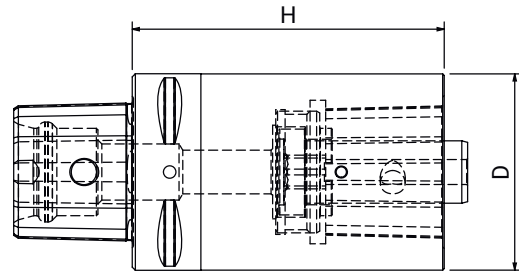

ISO 26623-1

COD	CONO	ATTACCO	D	H
XP3XP0C3	C32	C32	32	60
XP3XP1C3	C32	C32	32	80
XP4XP0C4	C40	C40	40	40
XP4XP1C4	C40	C40	40	60
XP4XP2C4	C40	C40	40	80
XP5XP0C5	C50	C50	50	50
XP5XP1C5	C50	C50	50	80
XP5XP2C5	C50	C50	50	100
XP6XP0C6	C63	C63	63	60
XP6XP1C6	C63	C63	63	100
XP6XP2C6	C63	C63	63	140
XP8XP0C8	C80	C80	80	65
XP8XP1C8	C80	C80	80	100
XP8XP2C8	C80	C80	80	125

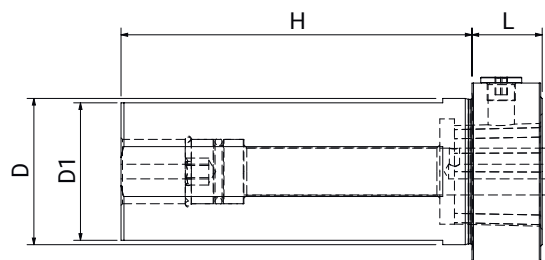
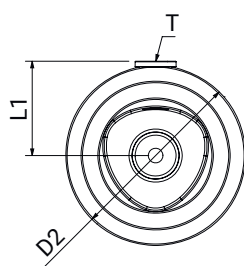

COD	ATTACCO	H	L	D2	D	D1	L1	T
D40XP132	C32	100	18	45,5	32	30	23	1/8 G
D40XP140	C40	100	20	51,5	40	37	26	1/8 G
D50XP150	C50	120	24	61,5	50	47	33	1/8 G
D50XP050	C50	80	24	61,5	50	47	33	1/8 G

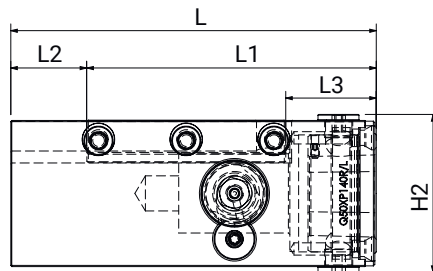
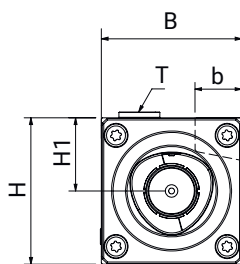

COD	ATTACCO	L	L1	L2	L3	B	b	H	H1	H2	T
Q40XP132R/L	C32	95	78,5	16,5	25	38	19	40	20	62	1/8 G
Q50XP140R/L	C40	125	100	25	31	42	24	50	25	57,5	1/8 G
Q63XP150R/L	C50	145	118	27	36	64	32	64	32	68	1/8 G

ISO 26623-1



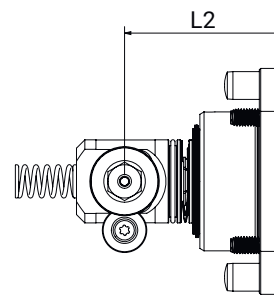
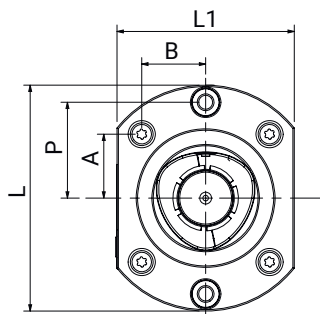

COD	ATTACCO	L	L1	L2	A	B	P
KITXP32D	<b>C32</b>	53,5	37,5	40,5	14,5	14,5	22,5
KITXP40D	<b>C40</b>	66,5	47,5	48,5	19,0	19,0	28,0
KITXP50D	<b>C50</b>	81,5	64,0	56,5	23,0	23,0	34,5
KITXP63D	<b>C63</b>	104,5	84,0	74,0	30,0	30,0	44,0
KITXP80D	<b>C80</b>	132,5	99,5	89,5	37,4	37,4	55,0

ISO 26623-1

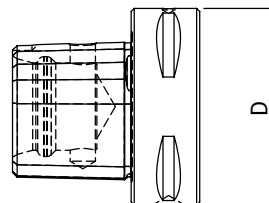

ISO 26623-1

COD	CONO	DESCRIZIONE	D
XP3TAPPO	C32	TAPPO DI PROTEZIONE POLIGONALE	32
XP4TAPPO	C40	TAPPO DI PROTEZIONE POLIGONALE	40
XP5TAPPO	C50	TAPPO DI PROTEZIONE POLIGONALE	50
XP6TAPPO	C63	TAPPO DI PROTEZIONE POLIGONALE	63
XP8TAPPO	C80	TAPPO DI PROTEZIONE POLIGONALE	80

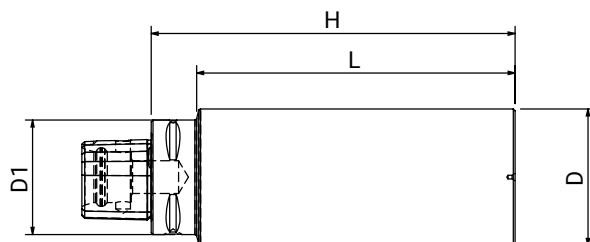

COD	CONO	D	H	L	D1
XP3ST3290	C32	32	90	75	32
XP3ST40110	C32	40	110	95	32
XP3ST50125	C32	50	125	110	32
XP3ST6090	C32	60	90	75	32
XP3ST7060	C32	70	60	45	32
XP3ST9070	C32	90	70	55	32
XP4ST4095	C40	40	95	75	40
XP4ST40120	C40	40	120	100	40
XP4ST60165	C40	60	165	145	40
XP4ST8075	C40	80	75	55	40
XP4ST80120	C40	80	120	100	40
XP4ST10085	C40	100	85	65	40
XP5ST50125	C50	50	125	105	50
XP5ST50150	C50	50	150	130	50
XP5ST63180	C50	63	180	160	50
XP5ST75175	C50	75	175	155	50
XP5ST9080	C50	90	80	60	50
XP5ST95150	C50	95	150	130	50
XP5ST11090	C50	110	90	70	50
XP6ST63180	C63	63	180	158	63
XP6ST75195	C63	75	195	173	63
XP6ST100300	C63	100	300	278	63
XP6ST11085	C63	110	85	63	63
XP6ST110120	C63	110	120	98	63
XP6ST120180	C63	120	180	158	63
XP6ST13095	C63	130	95	73	63
XP8ST80200	C80	80	200	170	80
XP8ST100200	C80	100	200	170	80
XP8ST100300	C80	100	300	270	80
XP8ST120160	C80	120	160	130	80
XP8ST90120	C80	90	120	100	80
XP8ST150200	C80	150	200	170	80
XP8ST160120	C80	160	120	90	80