

3

*Wide range of standard elements
to clamp special applications*

STD - StandardFLEX

Elementi Modulari / Modular Elements

VALIGETTA DI CAMPIONATURA STD (Art.1)

SAMPLE KIT CASE STD (Art.1)

NEW

Art. 981

 Valigetta di campionatura morsa Art.1 T.1
 Sample kit case Art.1 T.1 vise

Cod. 0.98.10000

All'Interno - Inside:			
	Art.132		Art.313
	Art.133		Art.314
	Art.138		Art.271
	Art.147		Art.283
	Art.212		-
	Art.217		-
			Art.298
			Art.370
			Art.375
			Art.376



3

SIMBOLOGIA DATI TECNICI

TECHNICAL DATA ICONS

GANASCE JAWS		Fissa Fixed		Mobile Movable		Intermedia Intermediate		Fissa con piastra singola Fixed with single plate		Fissa con piastra doppia Fixed with double plate
				Discendente Pull down		Piane Straight		Cambio rapido manuale Quick manual change		GRIP integrale Integral GRIP
PIASTRE GANASCE JAW PLATES										
POSSIBILITÀ POSSIBILITY		Serraggio di 1 particolare Clamping only 1 piece		Serraggio di 2 particolari Clamping 2 pieces		Montaggio sul fianco o in serie Side mounting or gang operation		Predisposizione Zero Point Zero Point ready		Cubi-morsa Vise tower
PAGINE PAGES										
						Accessori & Ricambi Accessories & Spare Parts		Istruzioni corretto utilizzo Instruction for a proper use		Diagrammi forze di serraggio Clamping force diagrams

Elementi modulari / Modular Elements

STD / StdFLEX



Precisione / Accuracy
 $\pm 0,02\text{mm}$



Durezza / Hardened
HRC 58 \pm 2

Elementi indipendenti per una versatilità estrema!
Independent elements for an extreme versatility!

USURA INESISTENTE / NO WEAR

Grazie all'accurata scelta dei materiali impiegati ed allo studio dimensionale computerizzato dei componenti. Costruzione completamente in speciali leghe di acciaio ad alta resistenza, normalizzato, cementato e temprato con durezza 58 \pm 2 HRC. Tutto ciò al fine di conferire massima rigidità, elevate prestazioni e usura inesistente. A riprova di tutto ciò assicuriamo **5 ANNI DI GARANZIA** su tutto il programma morse e organi meccanici in genere.

Thanks to the manufacturing with only the most suitable materials and to the structure of the vise components (developed using computer customised softwares and the experience gained during many years spent working on the specific field). High alloyed quality resistance steel, case hardened HRC 58 \pm 2, is used in manufacturing all the Gerardi vises and accessories in order to give maximum rigidity, high performances and no wear. As evidence we give **5 YEARS WARRANTY** on all the vises and mechanical components.

MODULARITÀ / MODULARITY

Tutte le morse ed accessori sono elementi componibili, intercambiabili e perfettamente allineabili fra loro e con i quali è possibile ottenere differenti soluzioni di bloccaggio. Secondo tale principio l'unico elemento che differenzia le attrezzature con identica larghezza di presa è la base (la cui lunghezza determina la massima apertura della morsa), mentre gli altri componenti sono identici. Mediante l'aggiunta o semplice sostituzione di alcuni particolari si può variare la tipologia di bloccaggio secondo le proprie esigenze utilizzando la stessa attrezzatura acquistata in un primo momento (bloccaggi singoli, con base girevole, doppi, verticali, di pezzi piani, tondi, piatti e grezzi, manuali, idraulici o pneumatici).

All vises and accessories are modular and components of all our vises will interchange with perfect alignment to provide different workholding solutions. With this basic principle the only difference between fixtures with the same width of clamping is the base (whose length determines the maximum opening of the vise), while the rest of components have same dimensions. Through the simple addition or substitution of some particulars You can change the type of clamping as Your needs require using the same fixture purchased before (single clamping, swivel base, double, vertical, smooth or round or flat or rough workpieces, manual, hydraulic or pneumatic).

DESIGN COMPATTO / SPACE SAVING DESIGN

La semplicità nonché la compattezza costruttiva consentono un'apertura notevole rispetto all'ingombro totale dell'attrezzatura. Inoltre lo stesso peso (solo 25 kg per una morsa da 150 mm di larghezza ganaschia) è tale da consentire un facile trasferimento da una macchina all'altra.

The space saving design and solid construction allow a maximum blocking ratio to total overall dimension of the vise. Furthermore the weight (only 25 kg for a 150 mm jaw width vise) allows a simple moving from one machine to another.

SERRAGGI RAPIDI / QUICK CLAMPING

Grazie allo scorrimento del gruppo di serraggio nella guida della base (a cremagliera) fino in prossimità del pezzo da lavorare dove si adatterà automaticamente alla nicchia più vicina. L'operazione di serraggio si conclude agendo sulla vite di bloccaggio. Oltre a quello manuale meccanico, sono disponibili 4 ulteriori sistemi di serraggio intercambiabili e indipendenti: 1 - Idraulici / 2 - Pneumatici / 3 - Idraulici manuali / 4 - Idraulici elettrici. L'operazione è in termini di secondi.

Thanks to the clamping device sliding in the vise base slide (compact rack type) till the proximity of the workpiece. The clamping is completed with the main screw. Besides the manual mechanic system, 4 further interchangeable and independent clamping systems are available: 1- Hydraulic / 2- Pneumatic / 3- Manual hydraulic / 4- Electrical hydraulic. The change needs only few seconds.



Doppia posizione *Double position*

Le ganasce fisse hanno la possibilità grazie alla doppia chiave di essere posizionate sia con piastri all'interno della base, sia con piastri che fuoriescono dalla base in modo da poter serrare anche particolari posizionati sul piano della tavola della macchina.

Fixed jaw has the possibility by the double key nuts, to be positioned both with jaw plates inside the vise base and with jaw plates externally from the vise base in order to be able to clamp even workpieces positioned on the machine table directly.

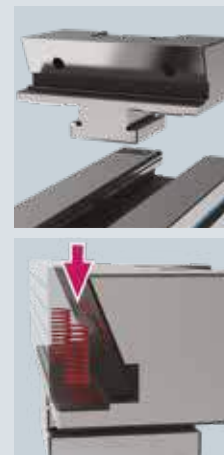

Ganascia monoblocco *Solid guided jaw*

Entrambe le ganasce sono costruite in corpo unico (non esistono slitte o tasselli di fissaggio) per garantire una maggiore rigidità e nessuna flessione. Entrambe le piastre ganasce sono costruite con un **angolo di spinta verso il basso**. Ciò assicura, nel momento della chiusura, una trazione del pezzo contro la base della morsa (per trascinamento) e di conseguenza un bloccaggio sicuro e preciso.

Both jaws bodies are built in one solid piece (no slides or key-nuts): in order to guarantee higher rigidity & no bendings. Both jaw plates are manufactured with a **pull down angle**. This ensures, during the clamping operation, a downward run of the workpiece against the vise base (by dragging) and thus a precise and safety clamping.



Fori filettati per sovraganascia *Threaded holes for stack type jaw*

Quattro fori filettati supplementari sopra le ganasce danno la possibilità di installare ganasce sovrapponibili per applicazioni speciali.

4 extra tapped holes over the jaws for special Gerardi stack type jaw application

Gli elementi modulari GERARDI sono la parte mobile e la parte fissa della morsa Standard sezionate e rese completamente indipendenti per permettere di ottimizzare i bloccaggi di pezzi particolarmente grandi, che richiedono le lavorazioni più gravose, sfruttando anche il piano della tavola della macchina come punto di appoggio. Gli elementi modulari sono sicuramente l'esempio più lampante dell'estrema versatilità del sistema modulare Gerardi. La disponibilità di una vastissima gamma di composizioni modulari permette di realizzare con soluzioni standard anche gli allestimenti che credevate speciali.

GERARDI modular elements are simply standard vises sections, the movable section and the fixed one, which in this way result completely independent for an extreme versatility and to allow you perfect clamping even of big workpieces which need the heaviest machining using the machine table as surface. Modular elements are the best example of the extreme versatility of the Gerardi modular system. The availability of the broadest assortment program allows to build with standard solutions even the fixtures you thought special. They are a solution for a lot of applications and, with the many reference points available, a perfect complement or alternative to single or double vises.

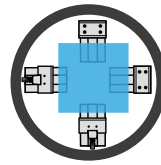

SCAN IT TO WATCH THE



VIDEO PRESENTATION



Ampia gamma di moduli standard per ottenere allestimenti speciali
Wide range of standard elements to clamp special applications

3

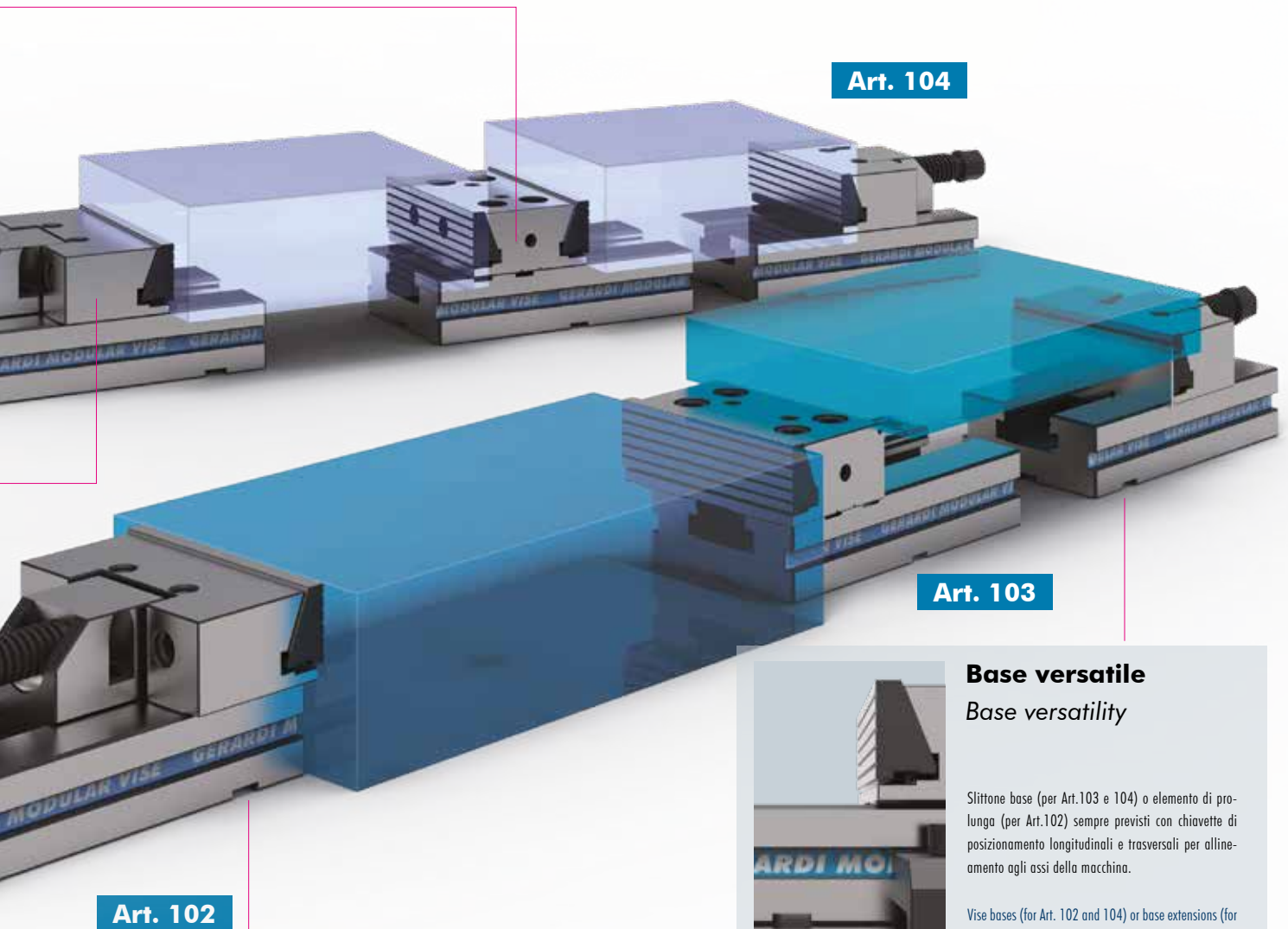

Art. 104

Art. 103

Art. 102



Base versatile

Base versatility

Slittone base (per Art.103 e 104) o elemento di prolunga (per Art.102) sempre previsti con chiavette di posizionamento longitudinali e trasversali per allineamento agli assi della macchina.

Vise bases (for Art. 102 and 104) or base extensions (for Art. 102) are always built with longitudinal and cross keyways in order to be aligned with the machine axis.



Staffe d'ancoraggio / Vise holding clamps

Standard / StandardFLEX

Coppia staffe di fissaggio Art.296, complete di vite e dado a "T"

Pair of vise holding clamps Art.296 complete of screw and "T" nuts



Esempio d'ordine per morsa tipo 3 su macchina con cave a T da 18mm: Art.296 T.3 X=18mm

Oppure con codice: 2.29.6300 X=18mm

Order example for Type 3 vise on machine with 18mm T-slots: Art.296 T.3 X=18mm

Also with code: 2.29.6300 X=18mm

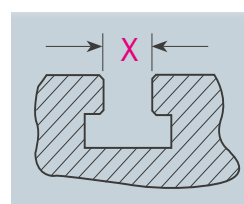

Cava a T

T Slot

Specificare sempre la cava della vostra macchina

Always specify the machine T-slot dimension

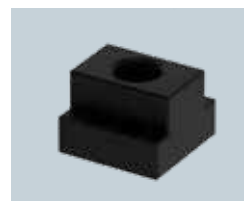

Art.287 (Pag.4.34)

Dadi a T - T Nuts

Per fissaggio morse alle cave a T della macchina

For vise clamping on the machine T-slots

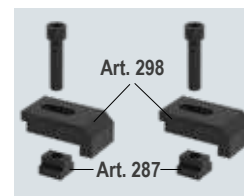

Art.296

(Art.298 + Art.287)

Consigliate 2 coppie di staffe Art.296 per ogni elemento modulare

Suggested 2 pairs of holding clamps Art.296 for each modular element

Tipo (grandezza) morsa Vise type (size)		1				1 - 2				3 - 4				5 - 6																		
Art. 296 Coppia di staffe Holding clamps pair	Cava a T slot X	12	14	16	18	12*	14	16	18	20	18*	20	22	16	18	20	22	18*	20	22	16	18	20	22	18*	20	22					
	T-nuts Ref. N°	8	9	10	11	12	13	14	20	21	22	32	33	34	20	21	22	23	32	33	34	20	21	22	23	32	33	34				
	Filetto vite Screw thread	M8				M10				M12 *				M16				M12 *				M16				M12				M16 *		
1 X M8 	A	50	50	50	50	50	50	50	50	76	76	76	76	76	76	76	76	86	86	86	86	86	86	86	86	86	86	86	86			
	B	24	24	24	24	24	24	24	24	30	30	30	30	30	30	30	30	40	40	40	40	40	40	40	40	40	40	40	40			
	C	6	6	6	6	6	6	6	6	6	6	6	6	6	6	6	6	10	10	10	10	10	10	10	10	10	10	10	10			
	Ø D	8,5	11	13	17	11	13	17	17	13	17	17	17	13	17	17	17	13	17	17	17	13	17	17	17	13	17	17	17			
	E	10	10	10	10	10	10	10	10	13	13	13	13	13	13	13	13	15	15	15	15	15	15	15	15	15	15	15	15			
	Ø F	14	-	-	-	-	-	-	-	-	-	-	-	-	-	-	-	-	-	-	-	-	-	-	-	-	-	-	-			
	G	14	16	17,5	19	16	17,5	19	19	17	16	16	16	16	16	16	16	26	26	26	26	26	26	26	26	26	26	26	26			
	G1	17	15	13	9	15	13	9	9	22	15	15	15	15	15	15	15	27	27	27	27	27	27	27	27	27	27	27	27			
	H	34	34	34	34	34	34	34	34	42	42	42	42	42	42	42	42	50	50	50	50	50	50	50	50	50	50	50	50			
	I	8	10	10	10	10	10	10	10	-	-	-	-	-	-	-	-	-	-	-	-	-	-	-	-	-	-	-	-			
	J	4	4	4	4	4	4	4	4	10	10	10	10	10	10	10	10	10	10	10	10	10	10	10	10	10	10	10	10			
T ± 0,1	15	15	15	15	15	15	15	15	20	20	20	20	20	20	20	20	26	26	26	26	26	26	26	26	26	26	26	26				
Cod.	2.29.61000 / M8	2.29.61000 / M10	2.29.61000 / M12	2.29.61000 / M16	2.29.63000 / M12	2.29.63000 / M12	2.29.63000 / M12	2.29.65000 / M12	2.29.65000 / M16																							

* Scelta consigliata - Suggested choice

* Scelta NON consigliata - NO Suggested choice

Soluzioni personalizzate / Customized solutions

Modular elements

Soluzioni personalizzate a tutti i vostri problemi di serraggio

Customized solutions for all your clamping problems

3

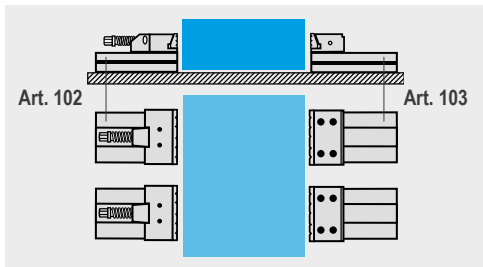

Esempio #1

Example #1

Particolari di grosse dimensioni posizionati direttamente sulla tavola machina

Huge workpieces clamped directly on the machine table

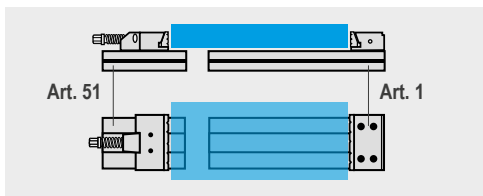

Esempio #2 Art.1 + 51

Example #2 Art.1 + 51

Art.258 + Art.127 inseriti in un elemento di prolunga Art.51

Art.258 + Art.127 to assemble them on a extension base Art.51

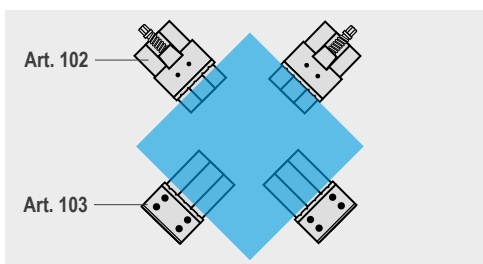

Esempio #3

Example #3

Particolari di medie dimensioni posizionati sugli elementi modulari

Medium size workpieces clamped directly on the vise sections

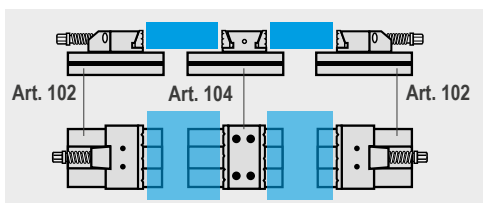

Esempio #4

Example #4

Elemento fisso doppio Art.104 + 2 elementi mobili Art.102

Double fixed vise section Art.104 + 2 movable vise section Art.102

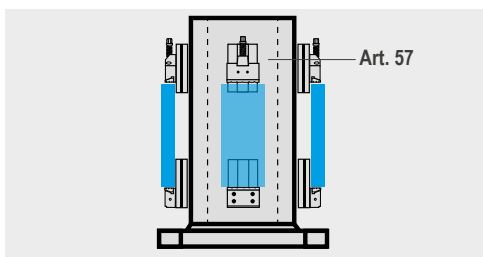

Esempio #5

Example #5

Elementi modulari su cubo a croce Art. 57

Modular elements assembled on cross cube type Art.57

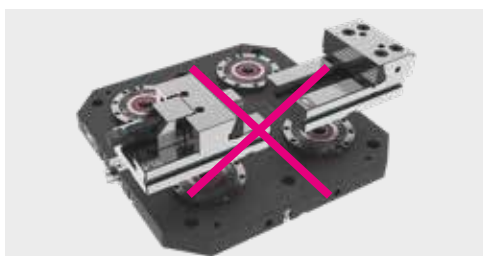

Utilizzo non conforme

Non compliant use

NON utilizzare gli elementi modulari in modo indipendente su due unità Zero Point senza collegarli tra di loro con una piastra d'interfaccia

NEVER mount modular elements independently on two Zero Point units without connecting them with an interface plate



3

Tipo (grandezza) morsa / Vise type (size)

Art. 102

Blocco tenditore completo di base.
Movable jaw section and base assy.

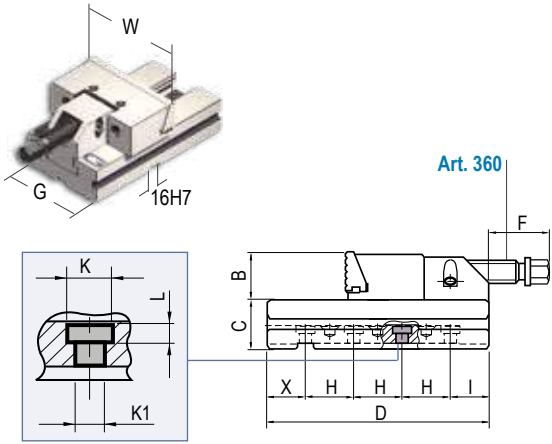

M = numero fori / M = holes number

kN	1 16 kN	2 25 kN	3 30 kN	4 30 kN	5 40 kN	6 40 kN
W	100	125	150	175	200	300
B	30	40	50	60	65	80
C	35	40	50	58	70	78
D	140	160	230	240	300	350
F	55	83	82	62	92	70
G	75	95	125	145	170	195
H	40	40	50	50	100	100
I	29	39	40	82,5	50	83
K1 Ø	6,5	8,5	13	13	17	17
K Ø	10,5	13,5	19	19	26	26
L	4,5	5,5	8,5	8,5	17	17
X	31	41	40	57,5	50	67
kg	3,4	6,3	14,2	20,8	35	60
M	3	3	4	3	5	5
Cod.	2.10.21000	2.10.22000	2.10.23000	2.10.24000	2.10.25000	2.10.26000

Disponibile anche versione **Art.112** con piastre piane - Also available **Art.112** version with straight plate jaws

Art. 103

Blocco fisso con ganascia fissa STD.
Fixed jaw section and base STD.

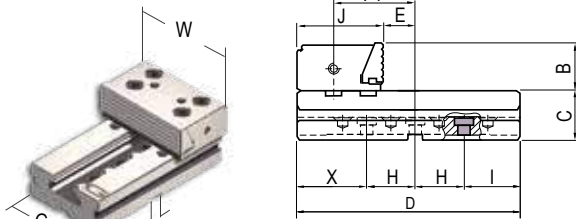

M = numero fori / M = holes number

J	77,9	77,9	89,4	96,9	113,4	120,4
E	33,6	33,6	33,6	33,6	33,6	33,6
F1	76	76	84,5	89	100	107
X	31	31	72,5	79	45	52
H	40	40	50	50	100	100
I	29	49	57,5	61	55	98
kg	3,3	5,8	12,6	17,8	29,8	50,5
M	3	3	3	4	5	5
Cod.	2.10.31000	2.10.32000	2.10.33000	2.10.34000	2.10.35000	2.10.36000

Disponibile anche versione **Art.113** con piastre piane - Also available **Art.113** version with straight plate jaws

Art. 104

Blocco fisso con ganascia doppia STD.
Fixed double jaw section and base STD.

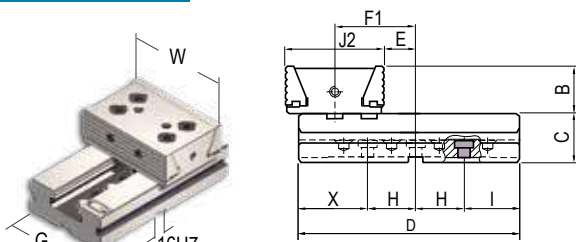

M = numero fori / M = holes number

J2	84,8	84,8	101,8	110,8	132,8	146,8
E	33,6	33,6	33,6	33,6	33,6	33,6
kg	3,4	6	13,3	18,8	30	52,5
M	3	3	3	4	5	5
Cod.	2.10.41000	2.10.42000	2.10.43000	2.10.44000	2.10.45000	2.10.46000

Disponibile anche versione **Art.114** con piastre piane - Also available **Art.114** version with straight plate jaws

Art. 102

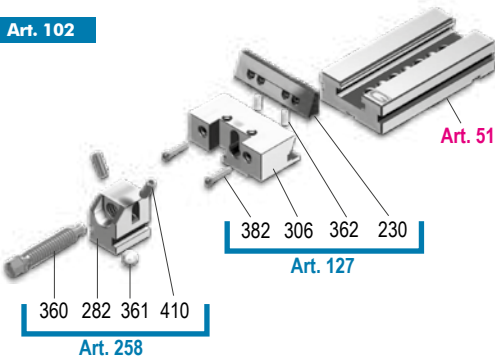

Art. 103

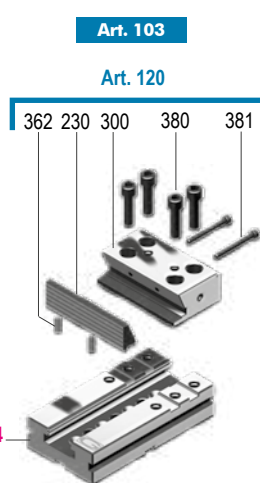

Art. 104

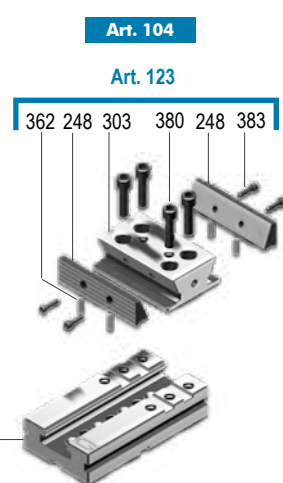

Art.	Pag.
44	3.12
44A	3.12
51	3.12
51A	3.12
120	4.8
123	4.8
127	4.8
230	4.9
248	4.9
258	4.36
282	4.36

Dotazione standard:

■ 1 coppia di tasselli di posizionamento Art. 297

Standard equipment:

■ 1 pair of positioning key-nuts Art. 297

Tipo (grandezza) morsa / Vise type (size)	1	2	3	4	5	6
kN	16 kN	25 kN	30 kN	30 kN	40 kN	40 kN
Art. 102A a reticolo / grid *	100	125	150	175	200	300
W	100	125	150	175	200	300
B	30	40	50	60	65	80
C	35	40	50	58	70	78
D	140	160	230	240	300	350
F	55	83	82	62	92	70
G	75	95	125	145	170	195
H1	50	50	50	50	100	100
I	54	39	40	57,5	69	83
K2 Ø	25	25	25	25	25	25
K3 Ø	16 ^{F7}	16 ^{F7}	16 ^{F7}	16 ^{F7}	16 ^{F7}	16 ^{F7}
L2	8	8	10	10	10	10
X	36	21	40	32,5	31	67
kg	3,4	6,3	14,2	20,8	35	60
M	2	3	4	4	3	3
Cod.	2.10.2A100	2.10.2A200	2.10.2A300	2.10.2A400	2.10.2A500	2.10.2A600

Blocco tenditore completo di base per posizionamento con viti calibrate
 Movable jaw section and base assy for positioning through shoulder screws

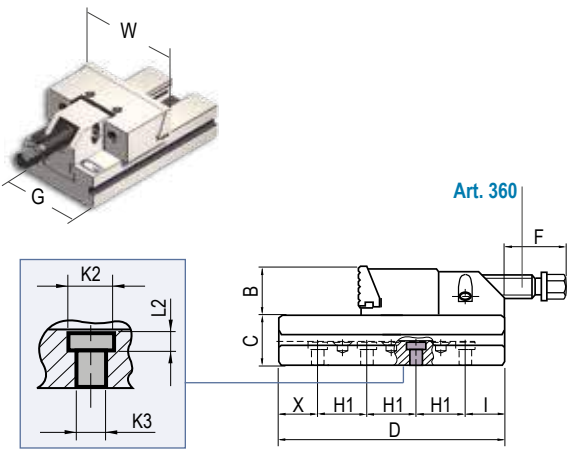

Foro calibrato / Calibrated hole M = numero fori / M = holes number

Art. 103A a reticolo / grid *	77,9	77,9	89,4	96,9	113,4	120,4
J	77,9	77,9	89,4	96,9	113,4	120,4
E	33,6	33,6	33,6	33,6	33,6	33,6
F1	76	76	84,5	89	100	107
X	61	21	72,5	29	45	52
H1	50	50	50	50	100	100
I	29	49	57,5	61	55	98
kg	3,3	5,8	12,6	17,8	29,8	50,5
M	2	2	3	4	3	3
Cod.	2.10.3A100	2.10.3A200	2.10.3A300	2.10.3A400	2.10.3A500	2.10.3A600

Blocco fisso con ganascia fissa per posizionamento con viti calibrate
 Fixed jaw section and base for positioning through shoulder screws

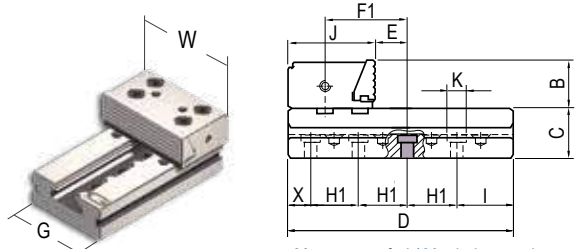

M = numero fori / M = holes number

Art. 104A a reticolo / grid *	84,8	84,8	101,8	110,8	132,8	146,8
J2	84,8	84,8	101,8	110,8	132,8	146,8
E	33,6	33,6	33,6	33,6	33,6	33,6
kg	3,4	6	13,3	18,8	30	52,5
M	2	2	3	4	3	3
Cod.	2.10.4A100	2.10.4A200	2.10.4A300	2.10.4A400	2.10.4A500	2.10.4A600

Blocco fisso con ganascia doppia per posizionamento con viti calibrate
 Fixed double jaw section and base for positioning through shoulder screws

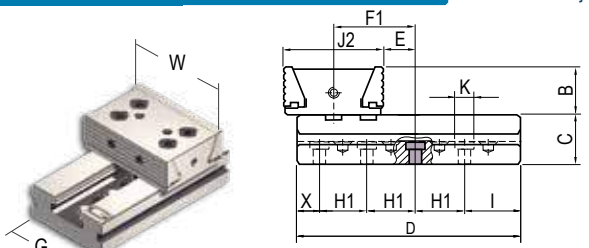

M = numero fori / M = holes number

Art.	Pag.
300	4.29
303	4.29
306	4.29
360	4.36
361	4.36
362	4.28
380	4.28
381	4.28
383	4.28
410	4.36

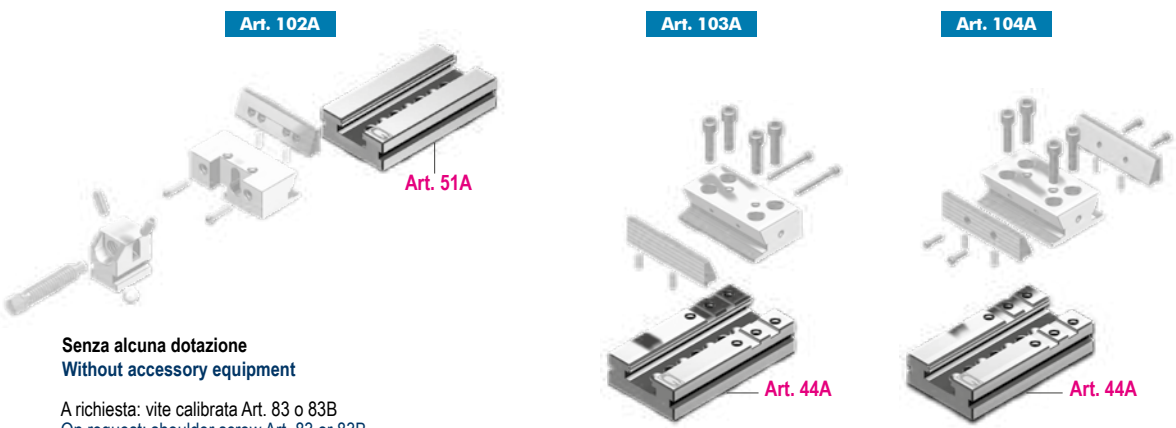

Senza alcuna dotazione
 Without accessory equipment
 A richiesta: vite calibrata Art. 83 o 83B
 On request: shoulder screw Art. 83 or 83B

* Passo del reticolo = 50 mm - Vite calibrata Ø 16F7 Grid Pitch = 50 mm - Shoulder screw Ø 16F7

3
Tipo (grandezza) morsa / Vise type (size)

	1	2	3	4	5	6
	16 kN	25 kN	30 kN	30 kN	40 kN	40 kN
W	96	121	146	171	196	296
B	28	38	48	58	63	78
C	35	40	50	58	70	78
D	140	160	230	240	300	350
F	55	83	82	62	92	70
G	75	95	125	145	170	195
H	40	40	50	50	100	100
I	29	39	40	82,5	69	83
K1 Ø	6,5	8,5	13	13	17	17
K Ø	10,5	13,5	19	19	26	26
L	4,5	5,5	8,5	8,5	17	17
X	31	41	40	57,5	31	67
kg	3,4	6,3	14,2	20,8	35	60
M	3	3	4	3	5	5
Cod.	3.10.2i100	3.10.2i200	3.10.2i300	3.10.2i400	3.10.2i500	3.10.2i600

Art. 102i

* Blocco tenditore con ganaschia a cambio rapido. (Sistema a pettine)
 * Movable jaw section with quick change jaw plate. (Comb system)

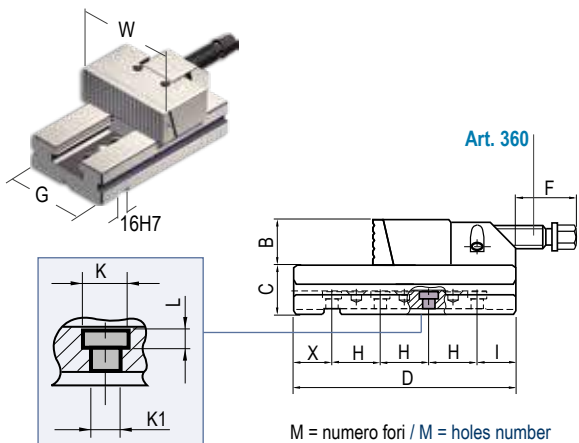

M = numero fori / M = holes number

* Serraggi disassati lateralmente non possibili * Offset lateral clamping not possible

Art. 103i

* Blocco fisso con ganaschia a cambio rapido. (Sistema a pettine)
 * Fixed jaw section with quick change jaw plate. (Comb system)

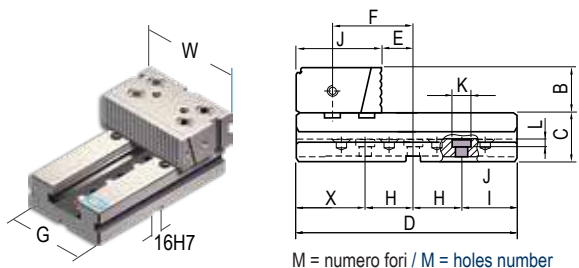

M = numero fori / M = holes number

J	77,9	77,9	89,4	96,9	113,4	120,4
E	33,6	33,6	33,6	33,6	33,6	33,6
F	76	76	84,5	89	100	107
X	31	31	72,5	29	45	52
H	40	40	50	50	100	100
I	29	49	57,5	61	55	98
kg	3,3	5,8	12,6	17,8	29,8	50,5
M	3	3	3	4	5	5
Cod.	3.10.3i100	3.10.3i200	3.10.3i300	3.10.3i400	3.10.3i500	3.10.3i600

* Serraggi disassati lateralmente non possibili * Offset lateral clamping not possible

Art. 104i

* Blocco fisso con ganaschia doppia a cambio rapido. (Sistema a pettine)
 * Fixed double-jaw section with quick change jaw plate. (Comb system)

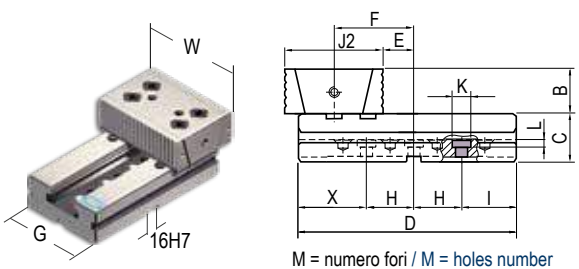

M = numero fori / M = holes number

J2	84,8	84,8	101,8	110,8	132,8	146,8
E	33,6	33,6	33,6	33,6	33,6	33,6
kg	3,4	6	13,3	18,8	30	52,5
M	3	3	3	4	5	5
Cod.	3.10.4i100	3.10.4i200	3.10.4i300	3.10.4i400	3.10.4i500	3.10.4i600

* Serraggi disassati lateralmente non possibili * Offset lateral clamping not possible

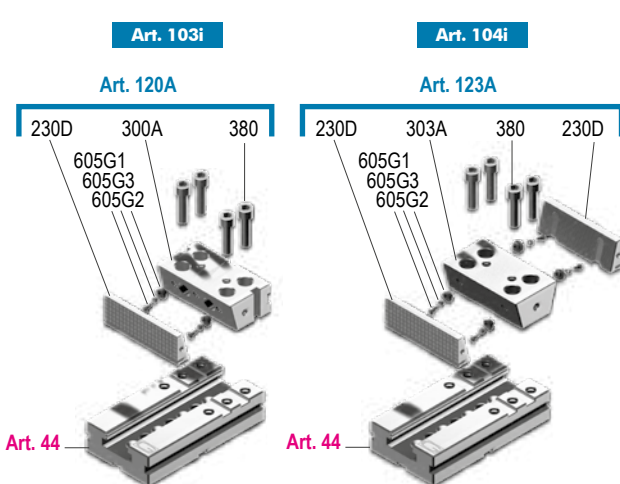
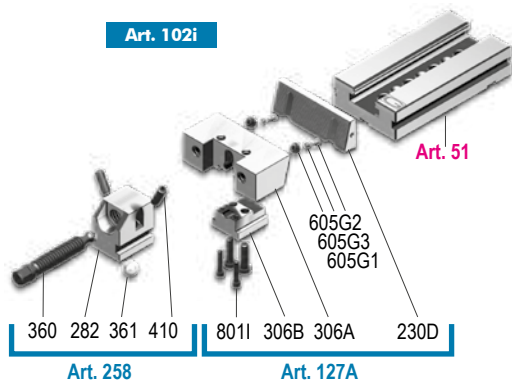

Art.	Pag.
44	3.12
44A	3.12
51	3.12
51A	3.12
120A	4.20
123A	4.20
127A	4.20
230D	4.21
258	4.36
282	4.36
300A	4.30

Dotazione standard:

■ 1 coppia di tasselli di posizionamento Art. 297 + 2 tappi Art. 291

Standard equipment:

■ 1 pair of positioning key-nuts Art. 297 + 2 insert Art. 291

Tipo (grandezza) morsa / Vise type (size)	kN	1 16 kN	2 25 kN	3 30 kN	4 30 kN	5 40 kN	6 40 kN
Art. 102Ai a reticolo / grid *	W	96	121	146	171	196	296
	B	28	38	48	58	63	78
	C	35	40	50	58	70	78
	D	140	160	230	240	300	350
	F	55	83	82	62	92	70
	G	75	95	125	145	170	195
	H1	50	50	50	50	100	100
	I	54	39	40	57,5	69	83
	K3 Ø	16 ^{F7}	16 ^{F7}	16 ^{F7}	16 ^{F7}	16 ^{F7}	16 ^{F7}
	K2 Ø	25	25	25	25	25	25
	L2	8	8	10	10	10	10
	X	36	21	40	32,5	31	67
	kg	3,4	6,3	14,2	20,8	35	60
	M	2	3	4	4	3	3
	Cod.	3.10.2Ai10	3.10.2Ai20	3.10.2Ai30	3.10.2Ai40	3.10.2Ai50	3.10.2Ai60

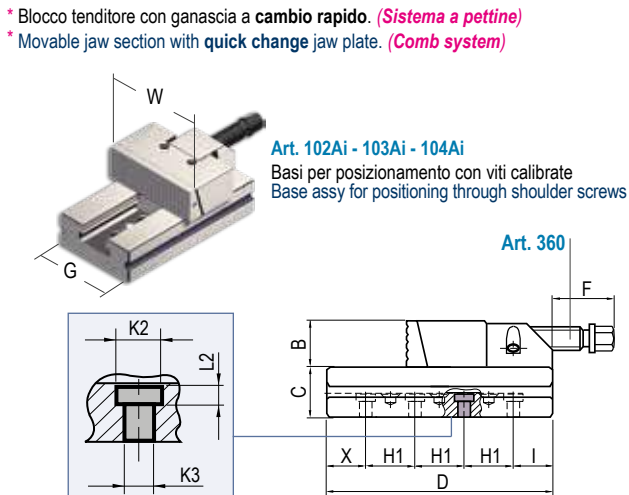

Foro calibrato / Calibrated hole M = numero fori / M = holes number

* Serraggi disassati lateralmente non possibili * Offset lateral clamping not possible

J	77,9	77,9	89,4	96,9	113,4	120,4
E	33,6	33,6	33,6	33,6	33,6	33,6
F1	76	76	84,5	89	100	107
X	61	21	72,5	29	45	52
H1	50	50	50	50	100	100
I	29	49	57,5	61	55	98
kg	3,3	5,8	12,6	17,8	29,8	50,5
M	2	2	3	4	3	3
Cod.	3.10.3Ai10	3.10.3Ai20	3.10.3Ai30	3.10.3Ai40	3.10.3Ai50	3.10.3Ai60

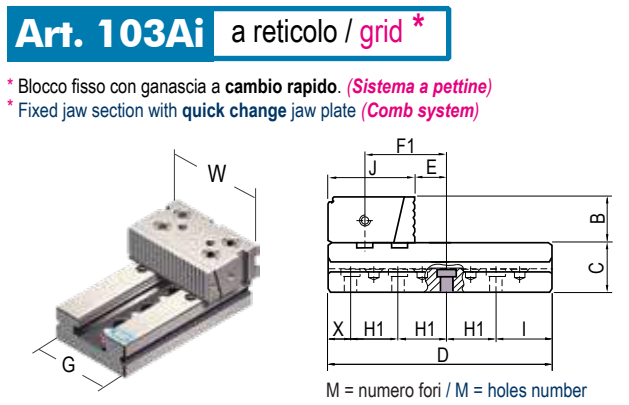

M = numero fori / M = holes number

* Serraggi disassati lateralmente non possibili * Offset lateral clamping not possible

J2	84,8	84,8	101,8	110,8	132,8	146,8
E	33,6	33,6	33,6	33,6	33,6	33,6
kg	3,4	6	13,3	18,8	30	52,5
M	2	2	3	4	3	3
Cod.	3.10.4Ai10	3.10.4Ai20	3.10.4Ai30	3.10.4Ai40	3.10.4Ai50	3.10.4Ai60

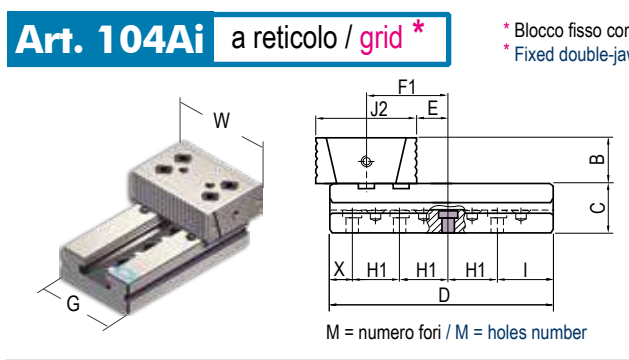

M = numero fori / M = holes number

* Serraggi disassati lateralmente non possibili * Offset lateral clamping not possible

Art.	Pag.
303A	4.30
306A	4.30
306B	4.30
360	4.36
361	4.36
380	4.28
410	4.36
605G1	4.22
605G2	4.22
605G3	4.22
8011	5.61

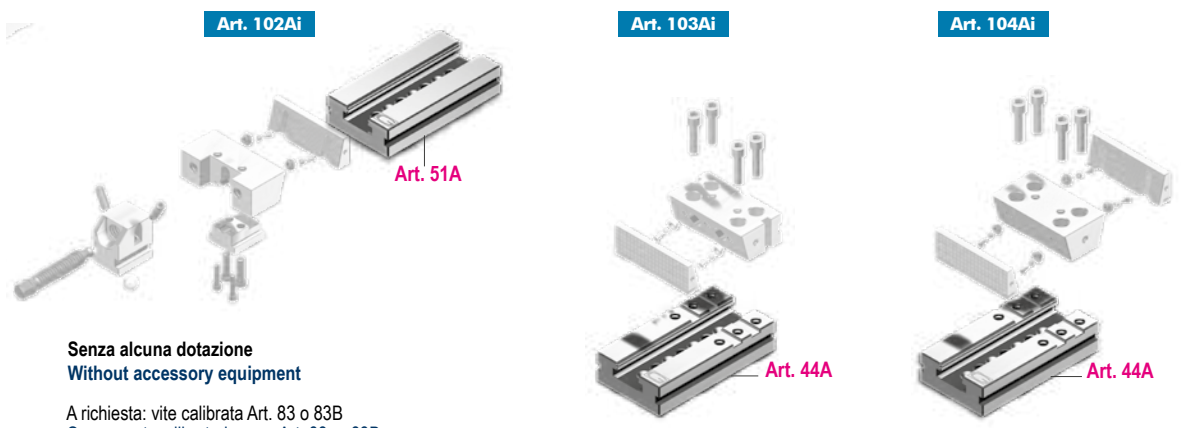

Senza alcuna dotazione
 Without accessory equipment
 A richiesta: vite calibrata Art. 83 o 83B
 On request: calibrated screw Art. 83 or 83B

* Passo del reticolo = 50 mm - Vite calibrata Ø 16F7 Grid Pitch = 50 mm - Shoulder screw Ø 16F7

ELEMENTI MODULARI BASE / Supplemento Extra per ogni foro calibrato +78€
BASIC MODULAR UNITS / Extra supplement for each ground hole +78€
3

Tipo (grandezza) / Type (size)	1	2	3	4	5	6
Art. 44						
G	75	95	125	145	170	195
D	140	160	230	240	300	350
kg	1.8	3.3	6.9	8	14.5	21.8
Cod.	1.80.14140	1.80.24160	1.80.34230	1.80.44250	1.80.54300	1.80.64350

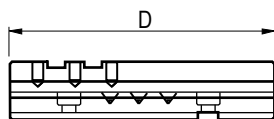
 Slittone base per ganascia fissa
 Split base for fixed jaw

Art. 44A						
D	140	160	230	240	300	350
kg	1.7	3.2	6.8	7.9	14.4	21.7
Cod.	3.44.A1000	3.44.A2000	3.44.A3000	3.44.A4000	3.44.A5000	3.44.A6000

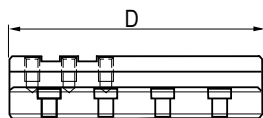
 Slittone base a reticolo (Passo 50 mm, Ø 16 per blocco fisso)
 Split grid (50 mm) pitch, Ø 16 base for fixed section

Art. 51						
D	140	160	230	240	300	350
kg	2.1	3.4	8.2	11.5	20	30
Cod.	1.80.13140	1.80.23160	1.80.33230	1.80.43250	1.80.53300	1.80.63350

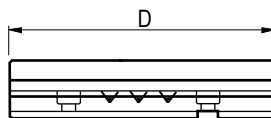
 Elemento di prolunga base per
 ganascia mobile
 Base extension for
 movable jaw

Art. 51A						
Cod.	3.51.A1000	3.51.A2000	3.51.A3000	3.51.A4000	3.51.A5000	3.51.A6000

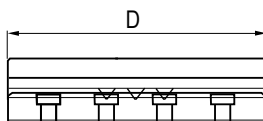
 Elemento di prolunga base a reticolo
 (Passo 50 mm, Ø 16)
 Grid (50 mm) pitch, Ø 16
 base extension

ACCESSORI
ACCESSORIES

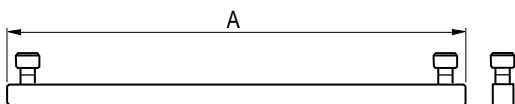
Tipo (grandezza) / Type (size)	1	2	3	4	5	6
Art. 358 Barra di tensione / Tension bar						
A	320	320	400	400	500	500
B	11	11	18	18	20	20
C	10	10	15	15	20	20
D	20	20	25	25	25	25
M	M6	M8	M12	M12	M16	M16
E	9	12	18	18	24	24
F	15	15	20	20	30	30
G	6	8	12	12	16	16
kg	0.5	0.5	1.2	1.2	2	2
Cod.	3.35.81000	3.35.82000	3.35.83000	3.35.84000	3.35.85000	3.35.86000

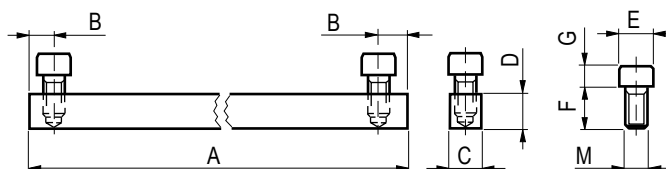
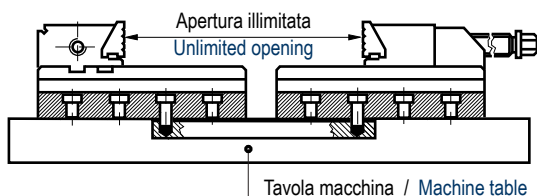

 Accessori per Art. 51 e 102
 A richiesta altre larghezze senza variazione di prezzo

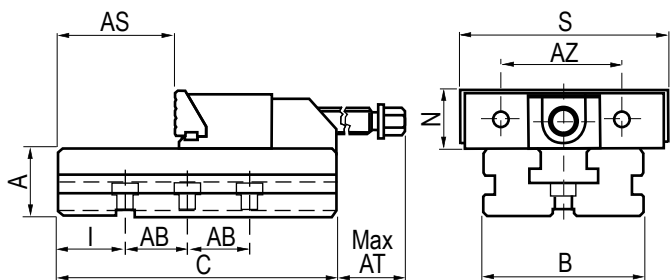
 Accessories for Art. 51 and 102
 Other widths available on request without price change

Art. 102

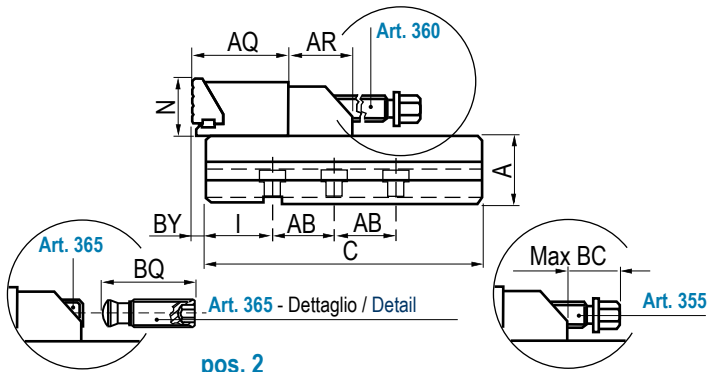

pos. 1



pos. 2

Art. 103

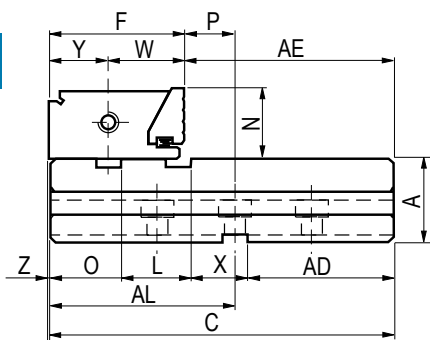

pos. 1

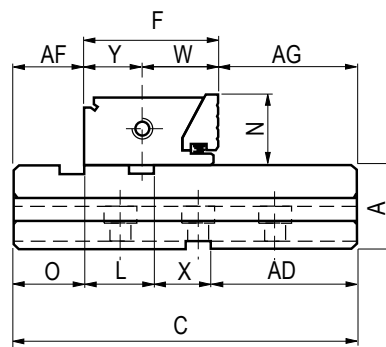

pos. 2

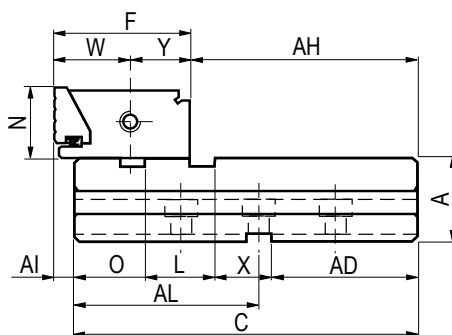

pos. 3

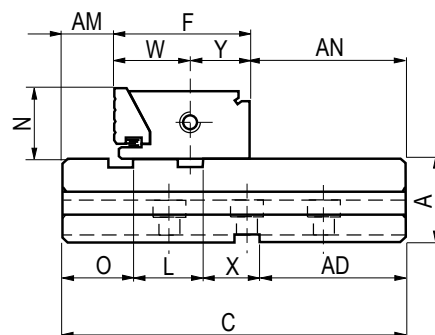

pos. 4

Art. 104

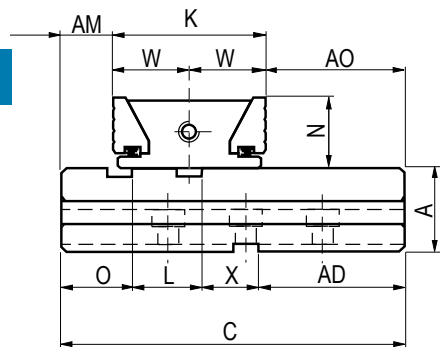

pos. 1

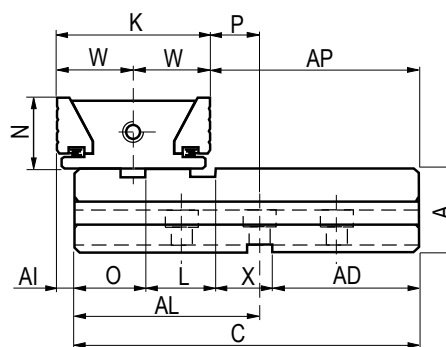

pos. 2

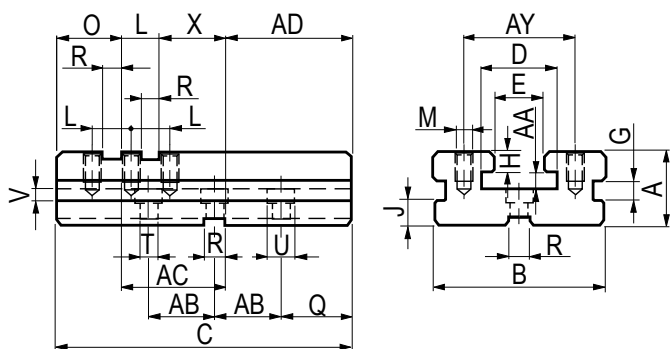

Art. 44

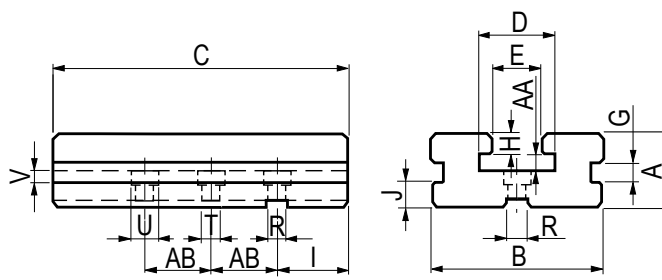

Art. 51

Art. 102A

pos. 1

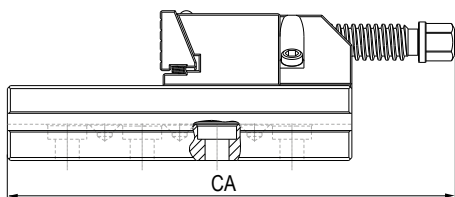

Art. 102Ai

pos. 2

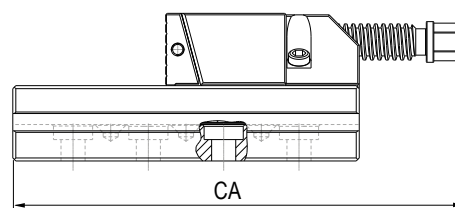

Art. 103A

pos. 1

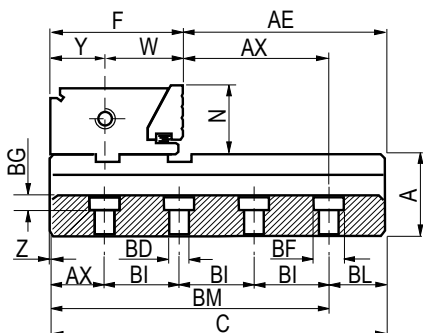

pos. 2

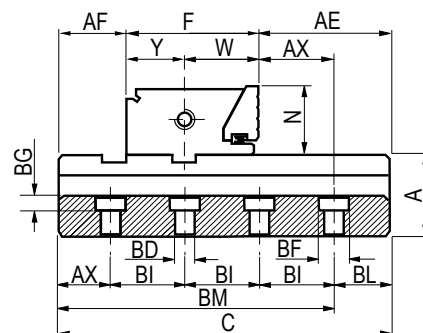

pos. 3

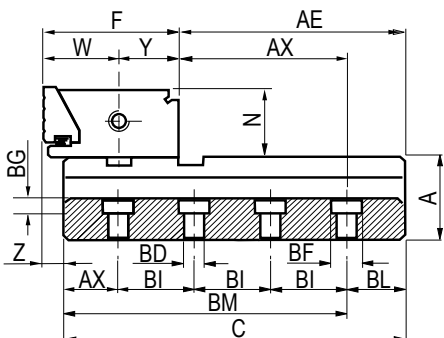

pos. 4

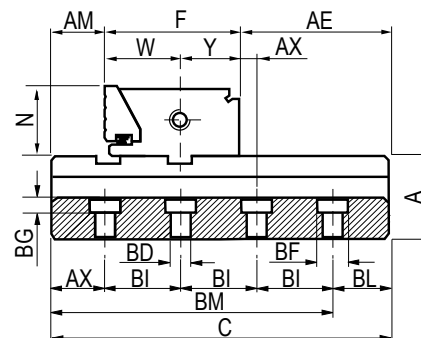

Art. 104A

pos. 1

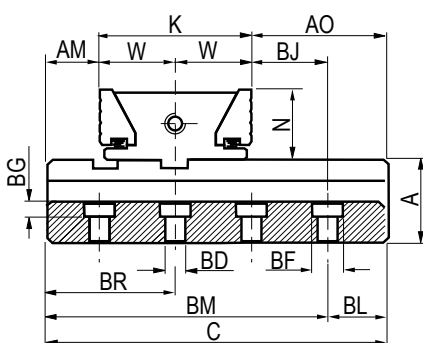

pos. 2

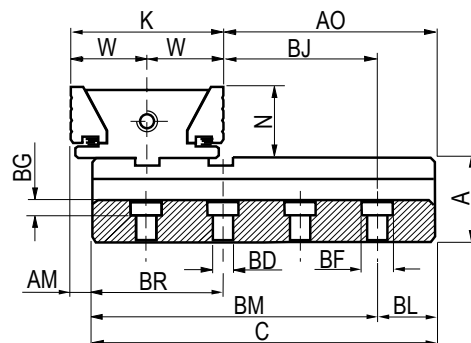

Art. 44A

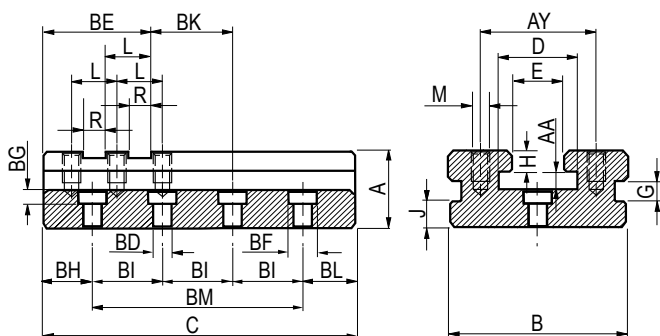

Art. 51A

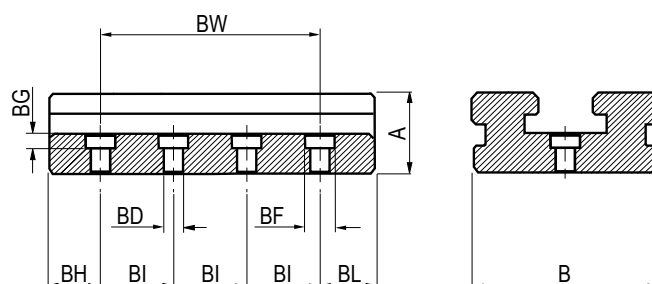



Tipo (grandezza) morsa / Vise (type) size

mm	1	2	3	4	5	6	Tolleranza Tolerance
A	35	40	50	58	70	78	- 0.02
B	75	95	125	145	170	195	- 0.02
C	140	160	230	240	300	350	
D	31	41	57	70	80	90	
E	21	28	41	51	61	71	+ 0.02
F	77.9	77.9	89.4	96.9	113.4	120.4	- 0.04
G	9.5	9.5	11.5	11.5	17.5	17.5	
H	10	10	13	15	20	20	- 0.02
I	31	41	40	57.5	31	67	
J	15	15	20	20	26	26	
K	84.8	84.8	101.8	101.8	132.8	146.8	- 0.04
L	32	32	36	36	44	44	- 0.02
M	M10	M12	M14	M16	M20	M20	
N	30	40	50	60	65	80	± 0.02
O	43	43	46	48	53	53	
P	33.6	33.6	33.6	33.6	33.6	33.6	± 0.02
Q	29	49	157.5	61	55	98	
R	16	16	16	16	16	16	H7
S	100	125	150	175	200	300	
T	6.5	8.5	13	13	17	17	
U	10.5	13.5	19	19	26	26	
V	4.5	5.5	8.5	8.5	17	17	
W	42.4	42.4	50.9	55.4	66.4	73.4	± 0.02
X	44	44	48.5	53	56	63	± 0.02
Y	35.5	35.5	35.5	41.5	47	47	± 0.02
Z	0.5	0.5	0.5	1.5	2	2	
AA	10	10	12	18	18	18	+ 0.04
AB	40	40	50	50	100	100	
AC	76	76	84.5	89	100	107	- 0.02
AD	21	41	99.5	103	147	190	
AE	62.6	82.6	141.6	144.6	188.6	231.6	
AF	31.5	31.5	35.5	35.5	42	42	
AG	30.6	50.6	105.1	108.6	144.6	187.6	
AH	69.5	89.5	153.5	158.5	208	258	
AI	7.4	7.4	12.9	15.4	21.4	28.4	
AJ	36	36	40.5	45	48	55	± 0.1
AK	80	80	120	120	160	240	± 0.01
	3 x Ø12	3 x Ø12	4 x Ø12	4 x Ø12	3 x Ø12	4 x Ø12	
AL	111	111	122.5	129	145	152	
AM	24.6	24.6	23.6	20.6	22.6	15.6	
AN	37.5	57.5	117.5	122.5	164	214	
AO	30.6	50.6	105.1	108.6	144.6	187.6	
AP	62.6	82.6	141.6	144.6	188.6	231.6	
AQ	50	60	80	90	100	120	
AR	32	51	48	68	78	94	
AS	28	49	102	82	122	136	
AT	55	68	82	62	92	70	
AU	45	38	47	27	52	45	

Tipo (grandezza) morsa / Vise (type) size

mm	1	2	3	4	5	6	Tolleranza Tolerance
AV	29	49	107.5	111	155	198	
AW	111	111	122.5	129	145	152	
AX	33.6	33.6	33.6	33.6	33.6	33.6	± 0.02
AY	50	62	88	100	120	133	
AZ	62	80	90	116	138	184	
BA							
BB	20	32	50	50	76	90	
BC	45	38	47	32	52	55	
BD	16	16	16	16	16	16	F7
BE	75	75	82	84	97	97	
BF	20.5	25	25	25	25	25	
BG	8	8	10	10	10	10	
BH	36	21	40	32.5	31	67	
BI	50	50	50	50	50	50	± 0.01
BJ	33.6	33.6	33.6	33.6	33.6	33.6	± 0.02
BK	36	36	40.5	45	48	55	± 0.01
BL	29	39	40	57.5	69	83	
BM	111	121	190	182.5	231	267	
BN	320	320	400	400	500	500	
BO	11	11	18	18	20	20	
BP	24.6	24.6	23.1	20.6	22.6	15.6	
BQ	35	35	38	40	45	45	
BR	67	67	74	76	89	89	
BS	12	12	12	12	12	12	F7
BT	20	20	20	20	20	20	
BU	8	8	8	8	8	8	
BV	31	31	42.5	49	65	72	
BW	100	100	150	150	200	200	± 0.01
	3 x Ø16	3 x Ø16	4 x Ø16	4 x Ø16	3 x Ø16	3 x Ø16	
BX	10	10	15	15	20	20	
BY	10	10	15	20	25	30	
BZ	40	40	40	40	40	40	± 0.01
CA	195	228	312	302	392	420	
CB							
CC	20	20	25	25	25	25	
CD	M6	M8	M12	M12	M16	M16	
CE	9	12	18	18	24	24	
CF	15	15	20	20	30	30	
CG	4	5	12	12	16	16	

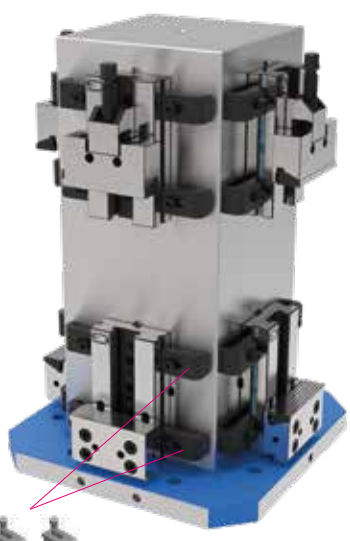

PREDISPOSIZIONE e MONTAGGIO ELEMENTI MODULARI su CUBI LAVORATI CUBE SET UP and MODULAR ELEMENTS MOUNTING on MACHINED TOMBSTONES

Cubo lavorato Art.53C Machined cube Art.53C	Tipo di morsa Vise type	Predisposizione e montaggio* Set-up & Mounting*	Cubo con morsa Cube with vises
<p>Cod. 8.53.C00220 Dim. A=550 / B=750 / H=850</p> 	<p>Art.102 Tipo 5 Art. 103 Type 5</p>  <p>n°morsa Vises n° x 4</p> <p>n°morsa Vises n° x 4</p>	<p>Per modulo / each modular element</p>  <p>Importo per lavorazioni necessarie per predisporre ogni faccia del cubo e montaggio più allineamento di ogni modulo.</p> <p>Amount needed for the set-up of each side and mounting + alignment of each modular element on it.</p>	 <p>Art.296</p>

* Predisposizione 4 facce, montaggio ed allineamento morsa incluso di viti, chiavette, staffe e quant'altro necessario.
4 Faces set-up, vises mounting including screws, keyways, holding clamps and all the necessary equipment.

Certificato di collaudo
Certificate test

MONTAGGIO e ALLINEAMENTO ELEMENTI MODULARI su CUBI a RETICOLO ALIGNMENT and MODULAR ELEMENTS MOUNTING on GRID TOMBSTONES

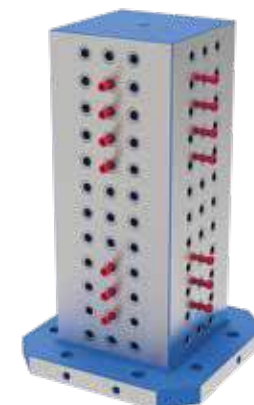
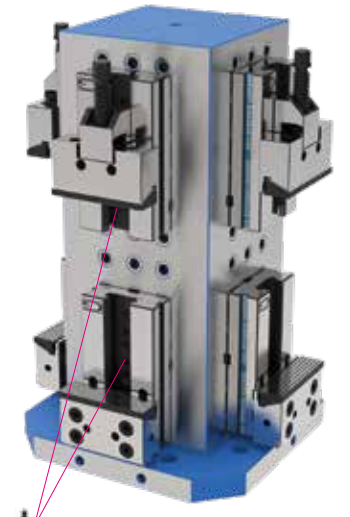
Cubo lavorato Art.53F Machined cube Art.53F	Tipo di morsa Vise type	Montaggio e allineamento* Mounting and alignment*	Cubo con morsa Cube with vises
<p>Cod. 8.53.F00220 Dim. A=550 / B=750 / H=850</p> 	<p>Art.102 Tipo 5 Art. 103 Type 5</p>  <p>n°morsa Vises n° x 4</p> <p>n°morsa Vises n° x 4</p>	<p>Per modulo / each modular element</p>  <p>Importo per montaggio ed allineamento di ogni modulo</p> <p>Amount need for each modular element mounting and alignment.</p>	 <p>Art.83</p>

* Montaggio e allineamento 4 morsa incluso di viti, chiavette, staffe e quant'altro necessario.
4 vises mounting and alignment includes screws, keyways, holding clamps and all the necessary equipment.

Certificato di collaudo
Certificate test

Diagrammi di serraggio / Clamping diagrams

Modular elements

Diagrammi di serraggio meccanico con chiave dinamometrica Mechanical clamping diagrams with torque wrench

3

Morse tipo 1 Vises type

Vite M12 - Passo 1,75mm - Screw M12 - Pitch 1,75mm

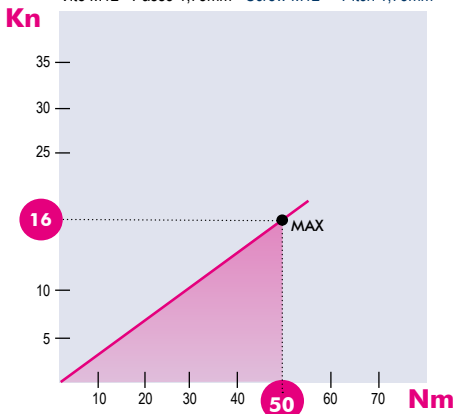

Art. 357

Morse tipo 2 Vises type

Vite TPN18 - Passo 4mm - Screw TPN18 - Pitch 4mm

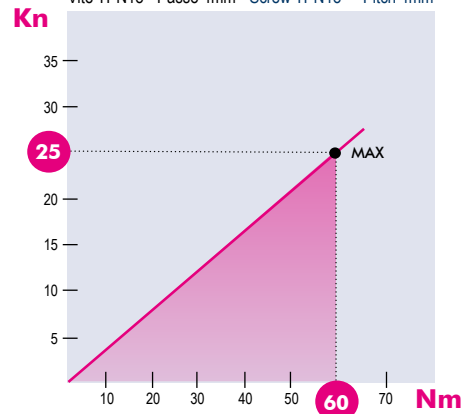

Gruppi di serraggio meccanici (Art. 258 e simili) / Mechanical clamping devices (Art. 258 and similar)

I diagrammi seguenti consentono di determinare le forze di serraggio ottenibili con le morse di varia grandezza (da 1 a 6), in funzione del momento applicato
The following diagrams give the clamping force that can be obtained with each vise type (size 1 to 6) depending on the torque

Morse tipo 3-4 Vises type

Vite TPN24 - Passo 5mm - Screw TPN24 - Pitch 5mm

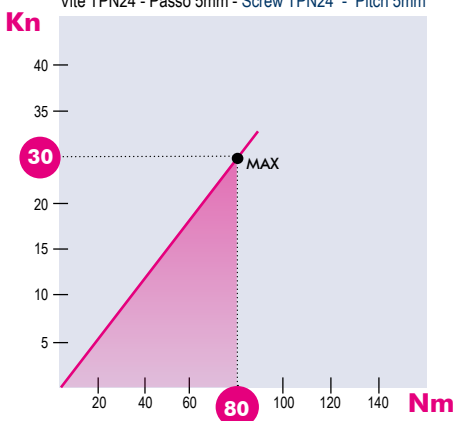

Art. 357

Morse tipo 5-6 Vises type

Vite TPN30 - Passo 5mm - Screw TPN30 - Pitch 5mm

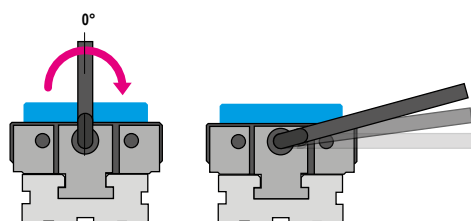
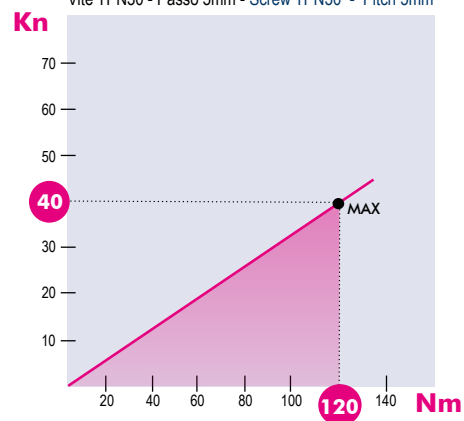

Serrare il pezzo agendo sulla vite di spinta con la chiave in dotazione senza utilizzare tubi o martelli.
Attenzione: nel serraggio basta 1/4 di giro della chiave dal momento in cui la ganaschia tocca il particolare.

Clamp the workpiece turning clockwise the main spindle through the box wrench without using tubes or hammers.
Attention: for the right clamping operation 1/4 of a turn of the box wrench is enough

Type (Size)	1	2	3	4	5	6
Kn	12	26	36	46	50	50

Valori indicativi Kn raggiunte a 90°
Kn indicative values at 90°

NB: Alcuni fattori, come la lubrificazione, lo staffaggio, gli attriti ed altro, possono modificare i valori indicati fino a ± 10%. Per un corretto utilizzo non superare i valori indicati nel grafico
Some factor as lubrication, clamping on the machine table, frictions and more can modify above values within a ± 10% range. For optimum operation do not exceed chart values.

CONTROLLO ALLINEAMENTO TRA CAVA TRASVERSALE E GANASCIA FISSA ALIGNMENT BETWEEN THE CROSS KEYWAY AND THE FIXED JAW PLATE



Libretto Istruzioni / Instruction Book

Scansiona il QR code e scarica le istruzioni complete

Scan the QR code to download the complete instructions

3 Posizionare la morsa verticalmente assicurandosi che sia perfettamente parallela al piano di appoggio **A** nei due sensi. Successivamente, con un comparatore centesimale, controllare il parallelismo del piano cava e della ganascia fissa.

Set the vise vertically ensuring that it is perfectly parallel to the table **A** in both sides. Then with an indicator check the parallelism of the keyway and its alignment with the fixed jaw plate.

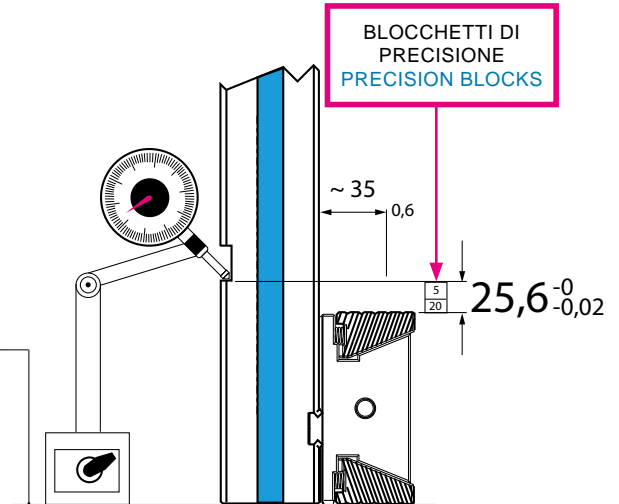
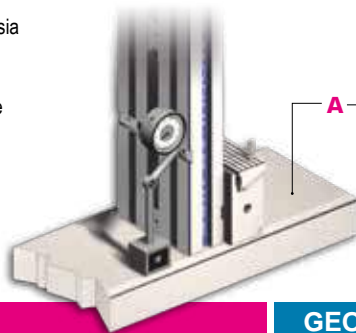

TOLLERANZE GEOMETRICHE

GEOMETRIC ACCURACIES

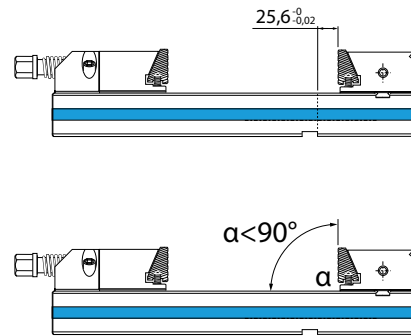
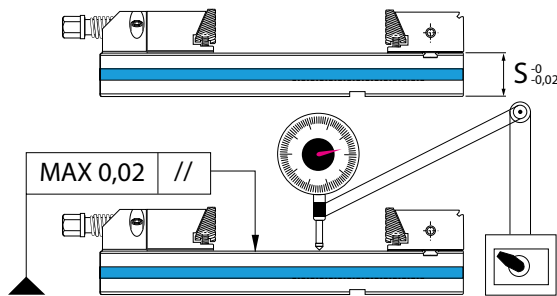

TOLLERANZE DINAMICHE

DYNAMIC ACCURACIES

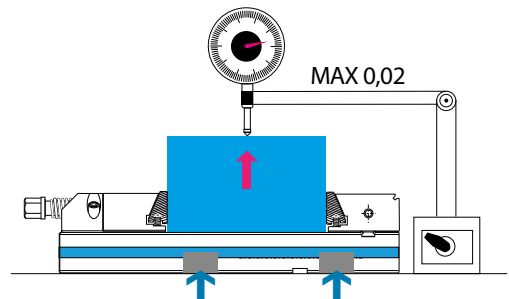
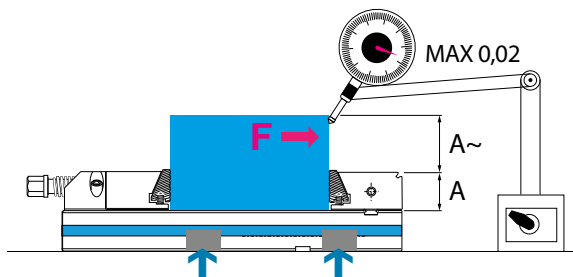

Morsa ancorata con 2 coppie di staffe Art.296 / Vise clamped with n. 2 pairs of Art.296

Valori di flessione nel punto "A" in relazione alle forze di serraggio **PER MORSE TIPO 3**
Deflection values at "A" in relation to clamping powers
FOR TYPE 3 VISES

1 kgf . m = 9.806 Nm

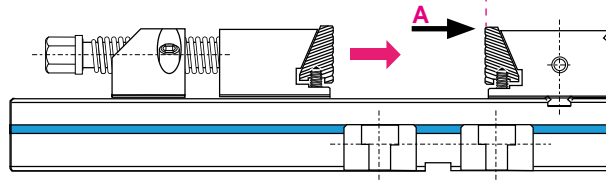

Kn	mm
60	0.1
50	0.07
40	0.05
30	0.03
20	0.02
10	0.01
5	0.004
2	0.002

Il sistema consigliato per l'ancoraggio della morsa sulla tavola macchina è tramite STAFFE Art.296. (Fig.1)

E' possibile ancorare la morsa tramite viti centrali, ma in questo caso la quota X potrebbe flettere e compromettere lo scorrimento della ganascia mobile. (Fig.2)

Nella tabella seguente sono riportati i valori di coppia massima applicabile mediante chiave dinamometrica

We recommend to fix the vises to the machine table using clamps Art. 296. (Fig. 1) The vise can be also fixed by means of central screws, but, this way, the X quota may suffer a bending and compromise the sliding of the movable jaws. (Fig. 2)

In the following table you can find the maximum torque values applicable through torque wrench.

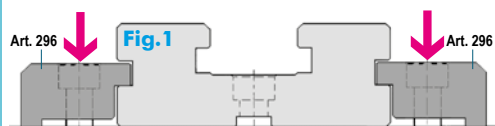

Vite Screw	M8	M10	M12	M16
Torque Nm	40	80	140	345

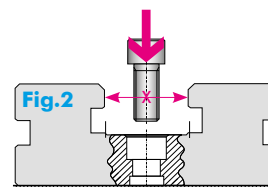

Type	1	2	3	4	5	6
Torque Nm	18	40	140	140	250	250
Viti - Screws	2	2	3	4	4	4