

B External tool Holder Code System(ISO)

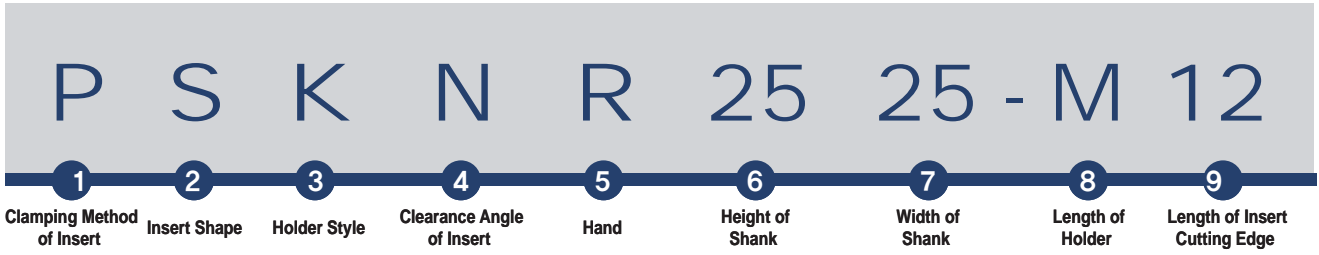

1 Clamping Method of Insert

P S K N R 25 25 - M 12

C
D
M
P
S
W

2 Insert Shape

P S K N R 25 25 - M 12

C
D
E
K

L
R
S
T

V
W

3 Holder Style

P S K N R 25 25 - M 12

B
D
E
F
G
J
K

L
N
R
S
T
V
Y

4 Clearance Angle of Insert

P S K N R 25 25 - M 12

B
C
D
E

F
N
P

5 Hand

P S K N R 25 25 - M 12

L
N
R

6 Height of Shank

P S K N R 25 25 - M 12

H

7 Width of Shank

P S K N R 25 25 - M 12

W

8 Length of Holder

P S K N R 25 25 - M 12

A - 32	H - 100	Q - 180
B - 40	J - 110	R - 200
C - 50	K - 125	S - 250
D - 60	L - 140	T - 300
E - 70	M - 150	U - 350
F - 80	N - 160	V - 400
G - 90	P - 170	W - 450

X-Special Item

9 Length of Insert Cutting Edge

P S K N R 25 25 - M 12

I



Double Clamp System

Cutting Shape										
Designation	DCBNR/L	DCKNR/L	DCLNR/L	DDJNR/L	DSBNR/L	DSDNN	DSKNR/L	DSSNR/L	DTFNR/L	DTGNR/L
Approach angle	75°	75°	95°	93°	75°	45°	75°	45°	90°	90°
Page	B154	B154	B154	B155	B155	B156	B156	B156	B157	B157
Turning	●		●	●	●	●		●		●
Copying				●						
Facing		●	●				●	●	●	
Chamfering						●				
Back turning			●	●						
Cutting Shape										
Designation	DVJNR/L	DVVNN	DWLNR/L							
Approach angle	93°	72.5°	95°							
Page	B157	B158	B158							
Turning	●	●	●							
Copying	●	●								
Facing			●							
Chamfering										
Back turning	●		●							

Lever Lock System

Cutting Shape										
Designation	PCBNR/L	PCKNR/L	PCLNR/L	PDJNR/L	PDNNR/L	PRDCN	PRGCR/L	PSBNR/L	PSDNN	PSKNR/L
Approach angle	75°	75°	95°	93°	62.5°	-	-	75°	45°	75°
Page	B159	B159	B160	B160	B161	B162	B162	B163	B163	B164
Turning	●	●	●	●	●	●	●	●	●	
Copying				●	●	●	●			
Facing			●							●
Chamfering										
Back turning			●	●						
Cutting Shape										
Designation	PSSNR/L	PTFNR/L	PTGNR/L	PTTNR/L	PWLNR/L					
Approach angle	45°	90°	90°	60°	95°					
Page	B164	B165	B165	B166	B166					
Turning	●		●	●	●					
Copying										
Facing	●	●			●					
Chamfering				●						
Back turning					●					

B Index for External Holder

Wedge Clamp System

Cutting Shape										
Designation	WTENN	WTJNR/L	WTXNR/L	WWLNR/L						
Approach angle	60°	93°	105°	95°						
Page	B167	B167	B167	B168						
Turning	●	●	●	●						
Copying	●	●	●							
Facing				●						
Chamfering										
Back turning		●	●	●						

Clamp on System

Cutting Shape										
Designation	CKJNR/L	CKNNR/L	CSDPN	CSKPR/L	CTFPR/L	CTGPR/L				
Approach angle	93°	62.5°	45°	75°	90°	90°				
Page	B169	B169	B169	B170	B170	B170				
Turning	●	●	●			●				
Copying	●	●								
Facing				●	●					
Chamfering										
Back turning	●									

Multi Lock System

Cutting Shape										
Designation	MCKNR/L	MCLNR/L	MCMNN	MCRNR/L	MDJNR/L	MDNNN	MDQNR/L	MSBNR/L	MSDNN	MSKNR/L
Approach angle	75°	95°	50°	75°	93°	62.5°	107.5°	75°	45°	75°
Page	B171	B171	B171	B172	B172	B172	B173	B173	B173	B174
Turning		●	●	●	●	●	●	●	●	
Copying					●	●	●			
Facing	●	●								●
Chamfering										
Back turning		●			●		●			

Cutting Shape										
Designation	MSRNR/L	MSSNR/L	MTENN	MTFNR/L	MTGNR/L	MTJNR/L	MVJNR/L	MVQNR/L	MVVNN	MWLNR/L
Approach angle	75°	45°	60°	90°	90°	93°	93°	117.5°	72.5°	95°
Page	B174	B175	B175	B175	B176	B176	B176	B177	B177	B177
Turning	●	●	●		●	●	●	●	●	●
Copying			●			●	●	●	●	
Facing		●		●		●				●
Chamfering										
Back turning						●	●	●		●



Screw on System

Cutting Shape										
Designation	SCACR/L	SCLCR/L	SDACR/L	SDJCR/L	SDNCN	SRDCN	SRGCR/L	SSBCR/L	SSDCN	SSKCR/L
Approach angle	90°	95°	90°	93°	62.5°	-	-	75°	45°	75°
Page	B178	B178	B178	B179	B179	B179	B180	B180	B180	B181
Turning	●	●	●	●	●	●	●	●	●	
Copying			●	●	●	●	●			
Facing		●								●
Chamfering										
Back turning		●		●						

Cutting Shape										
Designation	SSSCR/L	STACR/L	STFCR/L	STGCR/L	STTCR/L	SVABR/L	SVHBR/L	SVJBR/L	SVJCR/L	SVVBN
Approach angle	45°	90°	90°	90°	60°	90°	107.5°	93°	93°	72.5°
Page	B181	B181	B182	B182	B182	B183	B183	B183	B184	B184
Turning	●	●		●	●	●	●	●	●	●
Copying						●	●	●	●	●
Facing	●		●							
Chamfering										
Back turning						●	●	●	●	

Cutting Shape										
Designation	SVVCN									
Approach angle	72.5°									
Page	B184									
Turning	●									
Copying	●									
Facing										
Chamfering										
Back turning										

Ceramic Holder

Cutting Shape										
Designation	CCNLR/L	CRDNN	CRGNR/L	CSDNN	CSKNR/L	CTFNR/L	CTGNR/L			
Approach angle	95°	-	-	45°	75°	90°	90°			
Page	B185	B185	B185	B185	B186	B186	B186			
Turning	●	●	●	●			●			
Copying			●							
Facing	●				●	●				
Chamfering										
Back turning	●									

Instruction of External Holder

Double Clamp System

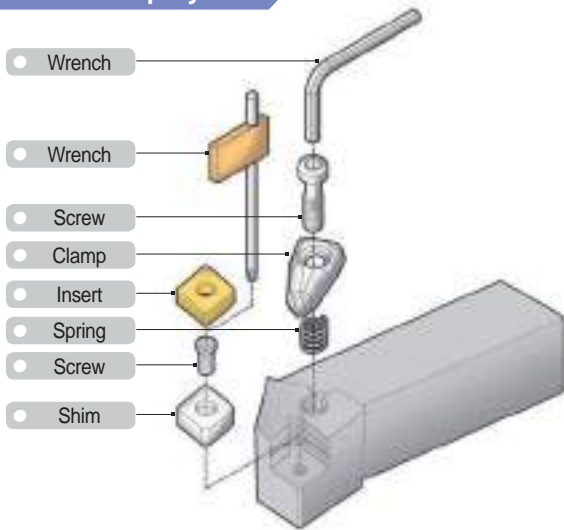

Lever Lock System

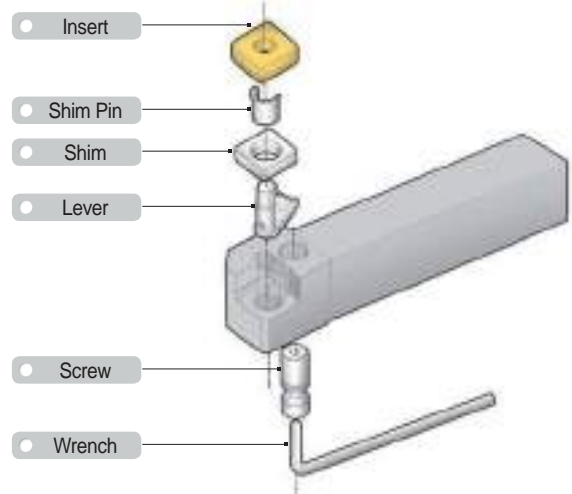

Wedge Clamp System

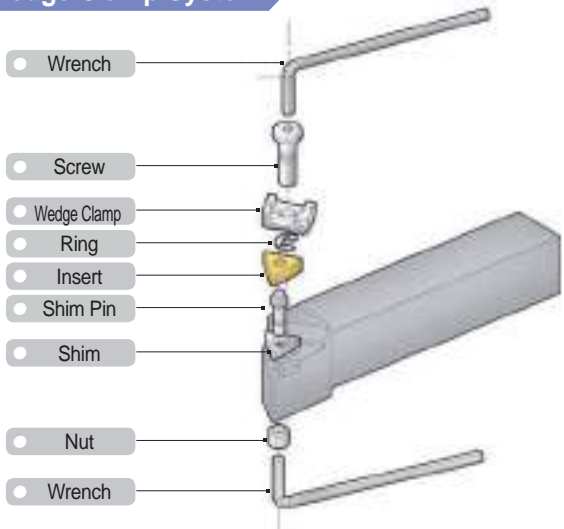

Clamp on System

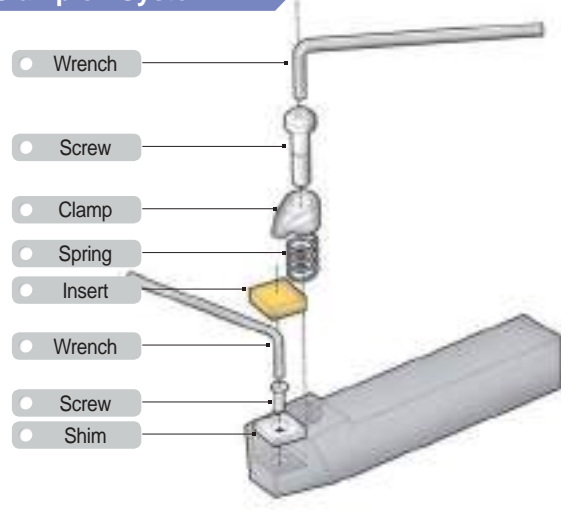

Multi Lock System

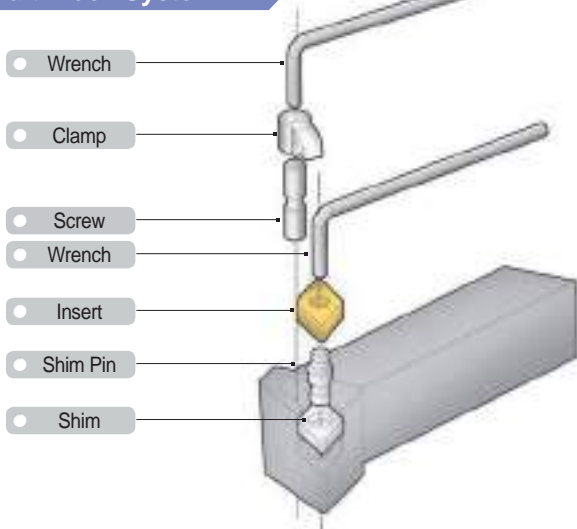

Screw on System

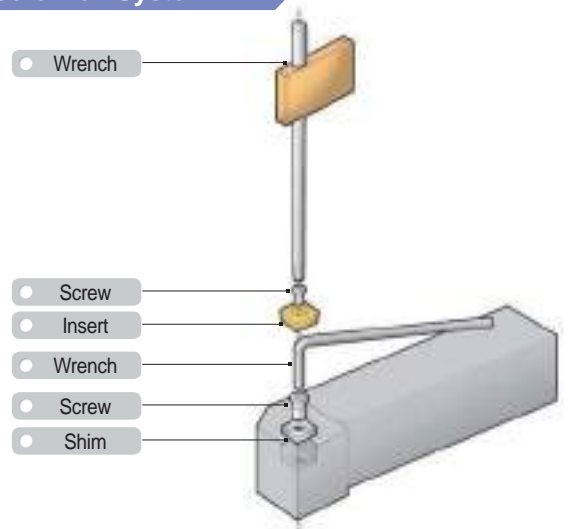

Double Clamp System

Stable clamping with double clamp system

- Features**
- Simple and powerful clamping system operated by only a single clamp screw
 - The powerful double-clamping system (upper and internal) is suitable for machining in very tough cutting conditions
 - The holder offers precision due to the special design in the rear of the clamp
 - Compact and optimized design for avoiding chip interference with a powerful clamp

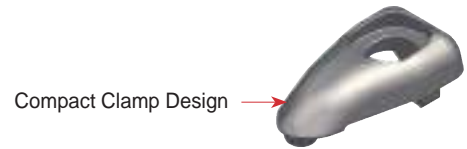
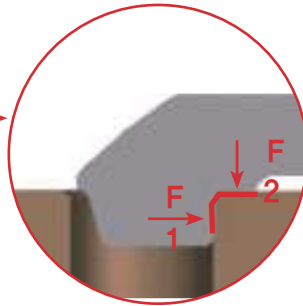
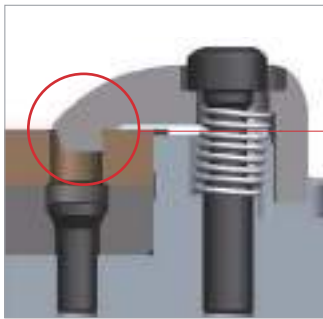
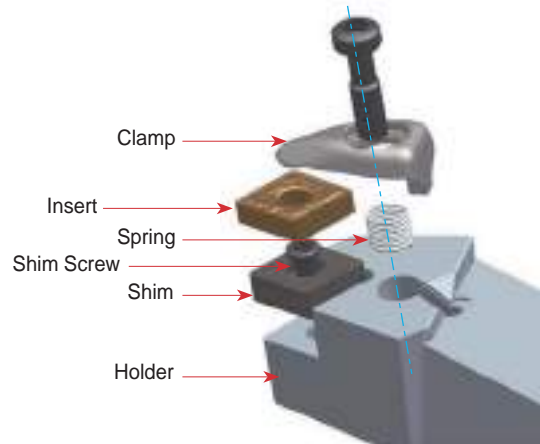

Lever Lock System

Excellent clamping stability and rigidity compared to existing lever-lock holders and boring bars

- Features**
- The holder offers precision due to the special design due to the improved Lever tip seat
 - The durability of parts has been improved
 - Superior tool life due to powerful clamping system and optimized design of part
 - Part designation on holder body makes it easy to check the right part description for each product
 - Adjustable coolant nozzle gives the option to change the direction of the coolant to optimize chip control and improve tool life

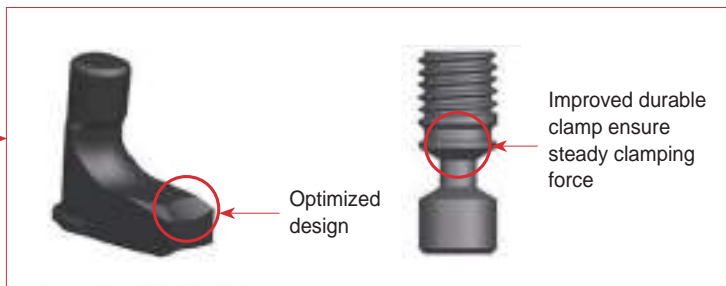
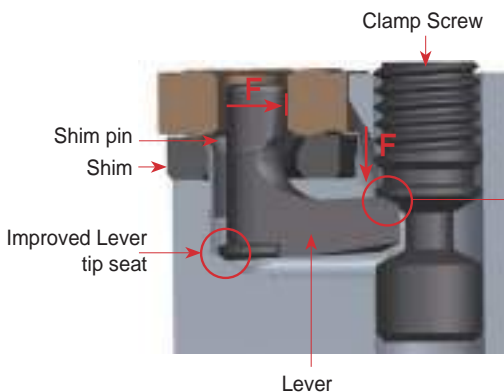
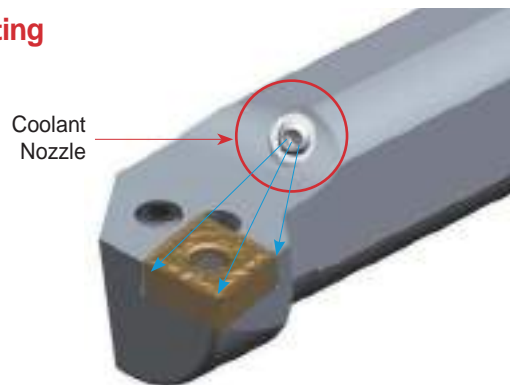

B Double Clamp System

DCBNR/L



CN□□

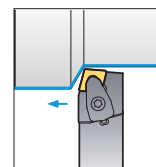
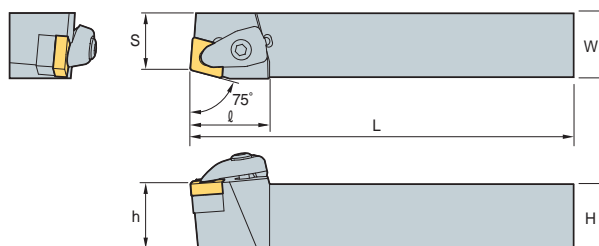

75°

• R type insert (mm)

Designation	Stock	H	W	L	S	h	ℓ	Insert	Clamp	Clamp Screw	Shim	Shim Screw	Spring	Wrench
DCBNR/L	2020-K12	20	20	125	17	20	31	CN□□1204□□						
	2525-M12	25	25	150	22	25	31							
	3225-P12	32	25	170	22	32	31							
	2525-M16	25	25	150	22	25	36							
	3232-P16	32	32	170	27	32	36	CN□□1606□□						
	3232-P19	32	32	170	27	32	40							
	4040-S19	40	40	250	35	40	40	CN□□1906□□						

➔ Applicable inserts B28-B35

DCKNR/L



CN□□

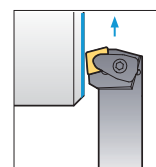
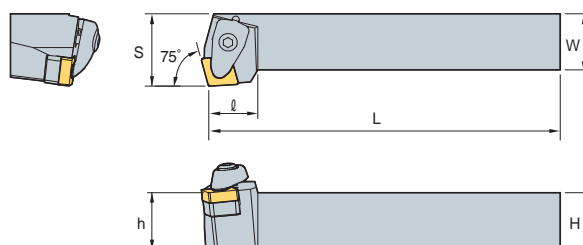

75°

• R type insert (mm)

Designation	H	W	L	S	h	ℓ	Insert	Clamp	Clamp Screw	Shim	Shim Screw	Spring	Wrench	
DCKNR/L	2020-K12	20	20	125	25	20	21	CN□□1204□□						
	2525-M12	25	25	150	32	25	21							
	3225-P12	32	25	170	32	32	21							
	3232-P16	32	32	170	40	32	26							
	4040-S16	40	40	250	50	40	26	CN□□1606□□						

➔ Applicable inserts B28-B35

DCLNR/L



CN□□

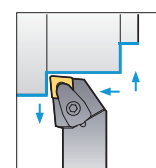
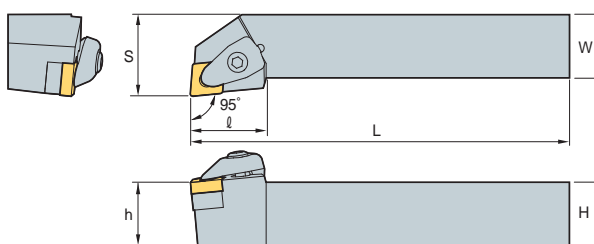

95°

• R type insert (mm)

Designation	H	W	L	S	h	ℓ	Insert	Clamp	Clamp Screw	Shim	Shim Screw	Spring	Wrench	
DCLNR/L	2020-K09	20	20	125	25	20	24.5	CN□□0903□□						
	2525-M09	25	25	150	32	25	24.5							
	2020-K12	20	20	125	25	20	30	CN□□1204□□						
	2525-M12	25	25	150	32	25	30							
	3225-P12	32	25	170	32	32	30							
	3232-P12	32	32	170	40	32	30							
	2525-M16	25	25	150	32	25	36	CN□□1606□□						
	3225-P16	32	25	170	32	32	36							
	3232-P16	32	32	170	40	32	36	CN□□1906□□						
	2525-M19	25	25	150	32	25	40							
	3225-P19	32	25	170	32	32	40							
	3232-P19	32	32	170	40	32	40							
	4040-S19	40	40	250	50	40	40							

➔ Applicable inserts B28-B35



DDJNR/L



DN□□

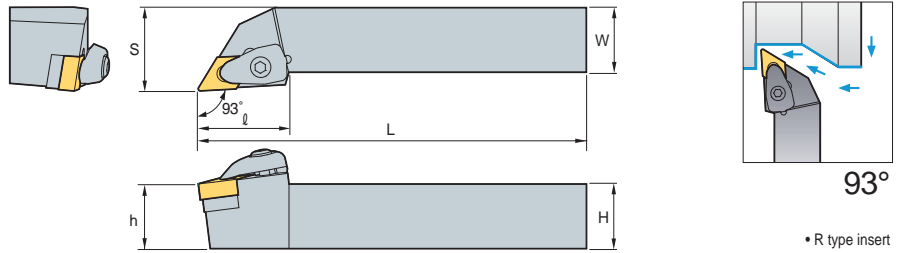

• R type insert (mm)

Designation	H	W	L	S	h	ℓ	Insert	Clamp	Clamp Screw	Shim	Shim Screw	Spring	Wrench
DDJNR/L 2020-K11	20	20	125	25	20	30	DN□□1104□□						
2525-M11	25	25	150	32	25	30							
3225-P11	32	25	170	32	32	30							
3232-P11	32	32	170	40	32	30	DN□□1506□□						
2020-K15	20	20	125	25	20	35							
2525-M15	25	25	150	32	25	35							
3225-P15	32	25	170	32	32	35							
3232-P15	32	32	170	40	32	35	DN□□1504□□						
2020-K15-3	20	20	125	25	20	35							
2525-M15-3	25	25	150	32	25	35							
3232-P15-3	32	32	170	40	32	35							

➔ Applicable inserts B36~B42

DSBNR/L



SN□□

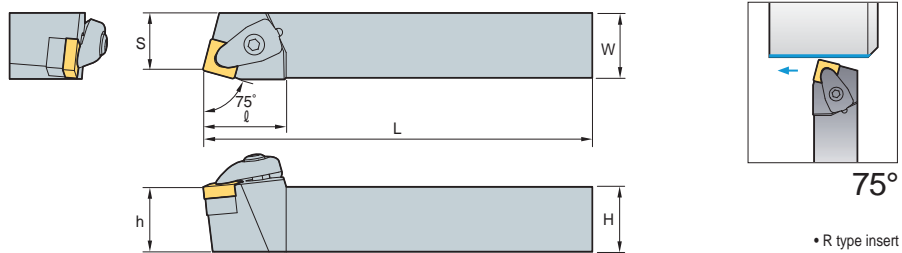

• R type insert (mm)

Designation	H	W	L	S	h	ℓ	Insert	Clamp	Clamp Screw	Shim	Shim Screw	Spring	Wrench
DSBNR/L 2020-K09	20	20	125	17	20	25	SN□□0903□□						
2525-M09	25	25	150	22	25	25							
2020-K12	20	20	125	17	20	32	SN□□1204□□						
2525-M12	25	25	150	22	25	32							
3225-P12	32	25	170	22	32	32							
3232-P12	32	32	170	27	32	32	SN□□1506□□						
2525-M15	25	25	150	22	25	38							
3225-P15	32	25	170	22	32	38							
3232-P15	32	32	170	27	32	38							
3232-P19	32	32	170	27	32	43	SN□□1906□□						
4040-S19	40	40	250	35	40	43							

➔ Applicable inserts B44~B52

B Double Clamp System

DSDNN

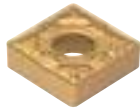

SN□□

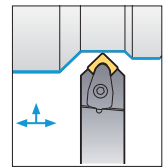
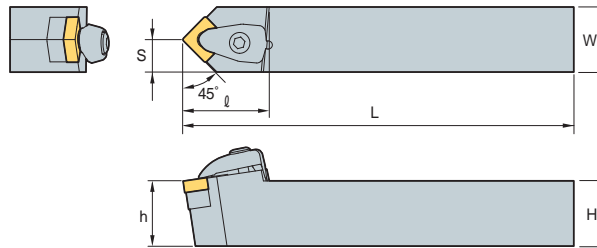

45°

• R type insert (mm)

Designation	H	W	L	S	h	ℓ	Insert	Clamp	Clamp Screw	Shim	Shim Screw	Spring	Wrench
DSDNN 2020-K09	20	20	125	10	20	26.5	SN□□0903□□	CVH3	CHX0415	SS32V	FTKA0307	SPR0510	HW25P
2020-K12	20	20	125	10	20	33	SN□□1204□□	CVH4	CHX0518	SS44V	FTKA0410	SPR0714	HW30P
2525-M12	25	25	150	12.5	25	33							
3225-P12	32	25	170	12.5	32	33							
3232-P12	32	32	170	16	32	33							
2525-M15	25	25	150	12.5	25	39.4	SN□□1506□□	CVH5	CHX0622	SS54V	FTNA0511	SPR0811	HW25P
3232-P15	32	32	170	16	32	38							
3232-P19	32	32	170	16	32	43							
4040-S19	40	40	250	20	40	45	SN□□1906□□	CVH6	CHX0622	SS64V	FTNA0511	SPR0811	HW40L

↻ Applicable inserts B44-B52

DSKNR/L

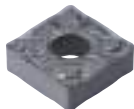

SN□□

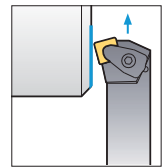
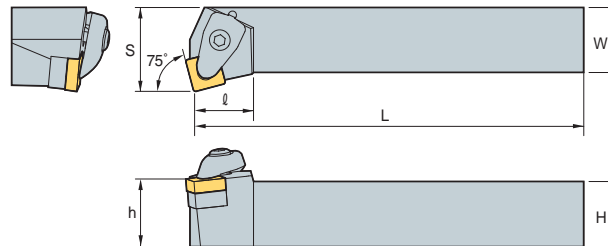

75°

• R type insert (mm)

Designation	H	W	L	S	h	ℓ	Insert	Clamp	Clamp Screw	Shim	Shim Screw	Spring	Wrench
DSKNR/L 2020-K09	20	20	125	25	20	20	SN□□0903□□	CVH3	CHX0415	SS32V	FTKA0307	SPR0510	HW25P
2020-K12	20	20	125	25	20	23	SN□□1204□□	CVH4	CHX0518	SS44V	FTKA0410	SPR0714	HW30P
2525-M12	25	25	150	32	25	23							
3232-P12	32	32	170	40	32	23							
3232-P15	32	32	170	40	32	28							
3232-P19	32	32	170	40	32	35	SN□□1506□□	CVH5	CHX0622	SS54V	FTNA0511	SPR0811	HW40L
4040-S19	40	40	250	50	40	43	SN□□1906□□	CVH6	CHX0622	SC64V	FTNA0511	SPR0811	HW40L

↻ Applicable inserts B44-B52

DSSNR/L



SN□□

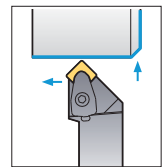
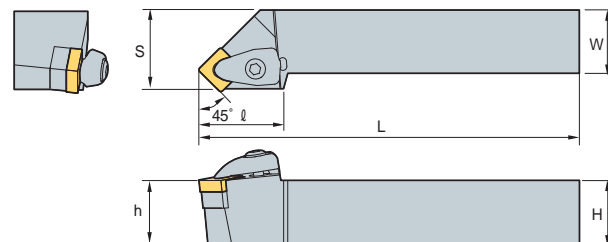

45°

• R type insert (mm)

Designation	H	W	L	S	h	ℓ	Insert	Clamp	Clamp Screw	Shim	Shim Screw	Spring	Wrench
DSSNR/L 2020-K09	20	20	125	25	20	28.5	SN□□0903□□	CVH3	CHX0415	SS32V	FTKA0307	SPR0510	HW25P
2020-K12	20	20	125	25	20	35	SN□□1204□□	CVH4	CHX0518	SS44V	FTKA0410	SPR0714	HW30P
2525-M12	25	25	150	32	25	35							
3225-P12	32	25	170	32	32	35							
3232-P12	32	32	170	40	32	35							
2525-M15	25	25	150	32	25	38.5	SN□□1506□□	CVH5	CHX0622	SS54V	FTNA0511	SPR0811	HW40L
3232-P15	32	32	170	40	32	38.5							
3232-P19	32	32	170	40	32	46							
4040-S19	40	40	250	50	40	46	SN□□1906□□	CVH6	CHX0622	SS64V	FTNA0511	SPR0811	HW40L

↻ Applicable inserts B44-B52



DTFNR/L



TN□□

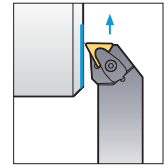
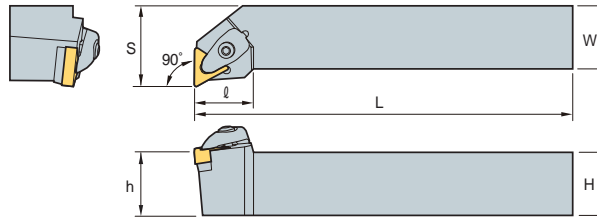

90°

• R type insert
(mm)

Designation	H	W	L	S	h	ℓ	Insert	Clamp	Clamp Screw	Shim	Shim Screw	Spring	Wrench
DTFNR/L 2020-K16	20	20	125	25	20	24.5	TN□□1604□□						
	25	25	150	32	25	24.5							
	32	32	170	40	32	23.5							
DTFNR/L 2525-M22	25	25	150	32	25	33	TN□□2204□□						
DTFNR/L 3225-P22	32	25	170	32	32	33							
DTFNR/L 3232-P22	32	32	170	40	32	33							

↻ Applicable inserts B53~B59

DTGNR/L



TN□□

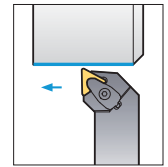
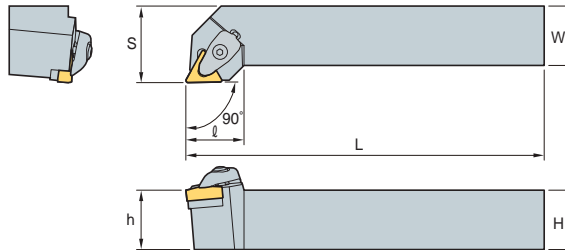

90°

• R type insert
(mm)

Designation	H	W	L	S	h	ℓ	Insert	Clamp	Clamp Screw	Shim	Shim Screw	Spring	Wrench
DTGNR/L 2020-K16	20	20	125	25	20	24.5	TN□□1604□□						
	25	25	150	32	25	24.5							
	32	32	170	40	32	24.5							
DTGNR/L 2525-M22	25	25	150	32	25	32.6	TN□□2204□□						
DTGNR/L 3225-P22	32	25	170	32	32	32.6							
DTGNR/L 3232-P22	32	32	170	40	32	32.6							

↻ Applicable inserts B53~B59

DVJNR/L



VN□□

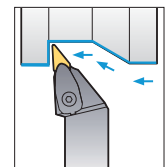
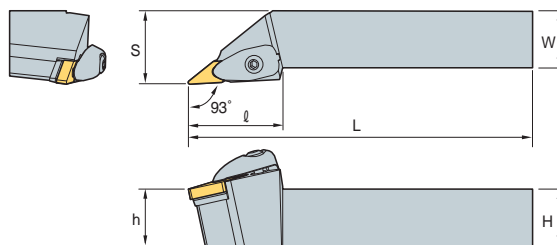

93°

• R type insert
(mm)

Designation	H	W	L	S	h	ℓ	Insert	Clamp	Clamp Screw	Shim	Shim Screw	Spring	Wrench
DVJNR/L 2020-K16	20	20	125	25	20	41.5	VN□□1604□□						
	25	25	150	32	25	41.5							
	32	32	170	40	32	41.5							
DVJNR/L 2525-M16	25	25	150	32	25	41.5	VN□□1604□□						
DVJNR/L 3232-P16	32	32	170	40	32	41.5							

↻ Applicable inserts B60~B61

B Double Clamp System

DVVNN



VN□□

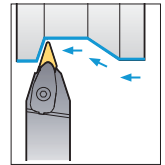
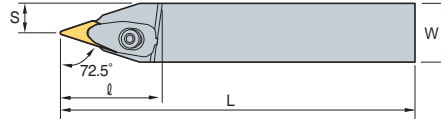
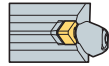

72.5°

• R type insert (mm)

Designation	H	W	L	S	h	ℓ	Insert	Clamp	Clamp Screw	Shim	Shim Screw	Spring	Wrench
DVVNN 2020-K16	20	20	125	10	20	40	VN□□1604□□						
2525-M16	25	25	150	12.5	25	40							
3232-P16	32	32	170	16	32	40							
								CVH3V	CHX0518	SV32V	FTNA03508	SPR0714	HW30P

➔ Applicable inserts B60~B61

DWLNRL/L



WN□□

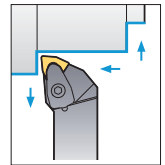
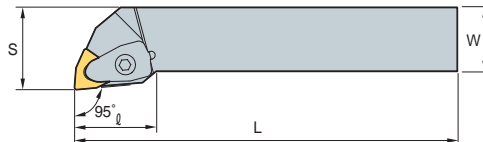
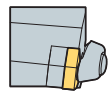

95°

• R type insert (mm)

Designation	H	W	L	S	h	ℓ	Insert	Clamp	Clamp Screw	Shim	Shim Screw	Spring	Wrench
DWLNRL/L 2020-K06	20	20	125	25	20	26	WN□□0604□□						
2525-M06	25	25	150	32	25	26							
2020-K08	20	20	125	25	20	32	WN□□0804□□						
2525-M08	25	25	150	32	25	32							
								CVH3	CHX0415	SW32V	FTKA0307	SPR0510	HW25P
								CVH4	CHX0518	SW44V	FTKA0410	SPR0714	HW30P

➔ Applicable inserts B62~B65



PCBNR/L

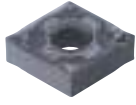

CN□□

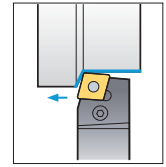
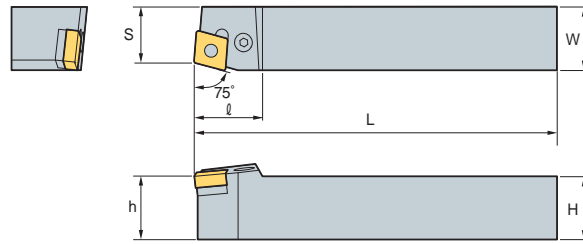

75°

• R type insert (mm)

Designation	H	W	L	S	h	ℓ	Insert	Lever	Screw	Shim	Shim Pin	Wrench	Shim Pin Punch	
PCBNR/L	2020-K12	20	20	125	17	20	CN□□ 1204□□	LV4	VHX0821	SC42	SP4	HW30L	LSPS4	
	2525-M12	25	25	150	22	25								27
	3225-P12	32	25	170	22	32								27
	2525-M16	25	25	150	22	25								33
	3232-P16	32	32	170	27	32	33	CN□□ 1606□□	LV5	VHX0825	SC53	SP5	HW30L	LSPS6
	3232-P19	32	32	170	27	32	36							
	4040-S19	40	40	250	35	40	36	CN□□ 1906□□	LV6N	VHX1027N	SC63N	SP6N	HW40L	LSPS6
	4040-S25	40	40	250	35	40	47							
4040-S25-5	40	40	250	35	40	47	CN□□ 2509□□	LV8N	VHX1236N	SC84N	SP8N	HW50L	LSPS8	
5050-T25	50	50	300	43	50	47	CN□□ 2507□□							
5050-T25	50	50	300	43	50	47	CN□□ 2509□□	LV8N	VHX1236N	SC84N	SP8N	HW50L	LSPS8	
PCBNR/L	2020-K12N	20	20	125	17	20	CN□□ 1204□□	LV4N	VHX0820N	SC42N	SP4N	HW30L	LSPS4	
	2525-M12N	25	25	150	22	25								27
	3225-P12N	32	25	170	22	32								27
	2525-M16N	25	25	150	22	25	33	CN□□ 1606□□L	LV6N	VHX1027N	SC63N	SP6N	HW40L	LSPS8
	3232-P16N	32	32	170	27	32	33							
	3232-P19N	32	32	170	27	32	36	CN□□ 1906□□	LV6N	VHX1027N	SC63N	SP6N	HW40L	LSPS8

↻ Applicable inserts B28-B35

PCKNR/L



CN□□

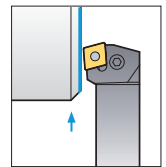
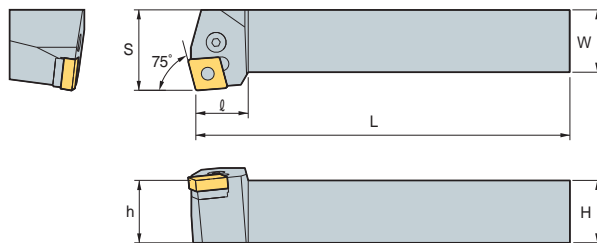

95°

• R type insert (mm)

Designation	H	W	L	S	h	ℓ	Insert	Lever	Screw	Shim	Shim Pin	Wrench	Shim Pin Punch	
PCKNR/L	2020-K12	20	20	125	25	20	CN□□ 1204□□	LV4	VHX0821	SC42	SP4	HW30L	LSPS4	
	2525-M12	25	25	150	32	25								27
	3225-P12	32	25	170	40	32								30
	3232-P16	32	32	170	40	32	26	CN□□ 1606□□	LV5	VHX0825	SC53	SP5	HW30L	HW30L
	4040-S16	40	40	250	50	40	25							
PCKNR/L	2020-K12N	20	20	125	25	20	CN□□ 1204□□	LV4N	VHX0820N	SC42N	SP4N	HW30L	LSPS4	
	2525-M12N	25	25	150	32	25								27
	3225-P12N	32	25	170	40	32	30	CN□□ 1606□□	LV5N	VHX0820AN	SC53N	SP5N	HW30L	LSPS5
	3232-P16N	32	32	170	40	32	26							

↻ Applicable inserts B28-B35



- Improved holders and parts ensure performance and durability
- “N” stand for New type (Holders and parts)



B Lever Lock System

PCLNR/L

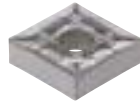

CN□□

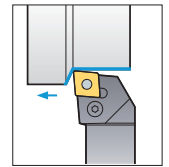
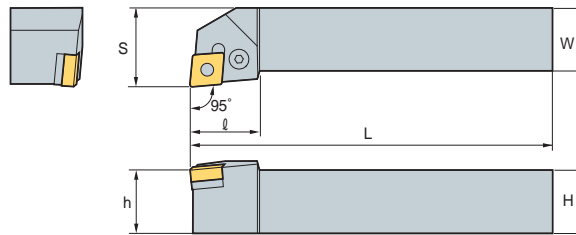

95°

• R type insert (mm)

Designation	H	W	L	S	h	l	Insert	Lever	Screw	Shim	Shim Pin	Wrench	Shim Pin Punch
PCLNR/L 1616-H09	16	16	100	20	16	20	CN□□ 0903□□	LV3	VHX0617	SC32	SP3	HW25L	LSPS3
2020-K09	20	20	125	25	20	22							
2525-M09	25	25	150	32	25	22							
1616-H12	16	16	100	20	16	28	CN□□ 1204□□	LV4	VHX0821	SC42	SP4	HW30L	LSPS4
2020-K12	20	20	125	25	20	28							
2525-M12	25	25	150	32	25	28							
3225-P12	32	25	170	32	32	28							
3232-P12	32	32	170	40	32	28							
2525-M16	25	25	150	32	25	33	CN□□ 1606□□	LV5	VHX0825	SC53	SP5	HW30L	LSPS5
3232-P16	32	32	170	40	32	33							
2525-M19	25	25	150	32	25	36	CN□□ 1906□□	LV6N	VHX1027N	SC63N	SP6N	HW40L	LSPS6
3225-P19	32	25	170	32	32	36							
3232-P19	32	32	170	40	32	36							
4040-P19	40	40	170	50	40	36							
4040-S19	40	40	250	50	40	36							
4040-S25	40	40	250	50	40	47	CN□□ 2509□□	LV8N	VHX1236N	SC84N	SP8N	HW50L	LSPS8
5050-T25	50	50	300	60	50	47							
4040-S25-5	40	40	250	50	40	47	CN□□ 2507□□	LV8N	VHX1236N	SC84N	SP8N	HW50L	LSPS8
5050-S25-5	50	50	300	60	50	47							
PCLNR/L 1616-H09N	16	16	100	20	16	20	CN□□ 0903□□	LV3N	VHX0617N	SC32N	SP3	HW25L	LSPS3
2020-K09N	20	20	125	25	20	22							
2525-M09N	25	25	150	32	25	22							
1616-H12N	16	16	100	20	16	28	CN□□ 1204□□	LV4N	VHX0817N VHX0820N	SC42N	SP4N	HW30L	LSPS4
2020-K12N	20	20	125	25	20	28							
2525-M12N	25	25	150	32	25	28							
3225-P12N	32	25	170	32	32	28							
3232-P12N	32	32	170	40	32	28							
2525-M16N	25	25	150	32	25	33	CN□□ 1606□□	LV5N	VHX0820AN	SC53N	SP5N	HW30L	LSPS5
3232-P16N	32	32	170	40	32	33							
2525-M19N	25	25	150	32	25	38	CN□□ 1906□□	LV6N	VHX1027N	SC63N	SP6N	HW40L	LSPS6
4040-S19N	40	40	250	50	40	36							

➔ Applicable inserts B28-B35

PDJNR/L



DN□□

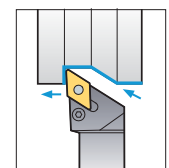
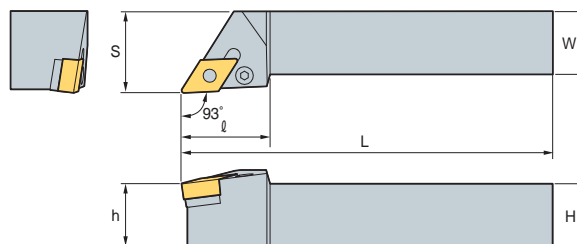

93°

• R type insert (mm)

Designation	H	W	L	S	h	l	Insert	Lever	Screw	Shim	Shim Pin	Wrench	Shim Pin Punch
PDJNR/L 1616-H11	16	16	100	20	16	25	DN□□ 1104□□	LV3	VHX0617	SD317	SP3	HW25L	LSPS3
2020-K11	20	20	125	25	20	25							
2525-M11	25	25	150	32	25	30							
2020-K15	20	20	125	25	20	35	DN□□ 1506□□	LV4B	VHX0821	SD42	SP4	HW30L	LSPS4
2525-M15	25	25	150	32	25	35							
3225-P15	32	25	170	32	32	35							
3232-P15	32	32	170	40	32	35							
2020-K15-3	20	20	125	25	20	35							
2525-M15-3	25	25	150	32	25	35	DN□□ 1504□□	LV4	VHX0821	SD42	SP4	HW30L	LSPS4
3232-P15-3	32	32	170	40	32	35							

➔ Applicable inserts B36-B42



PDJNR/L



DN□□

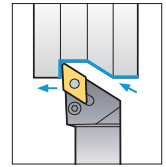
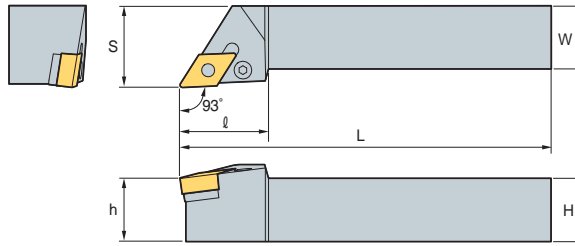

93°

• R type insert (mm)

Designation	H	W	L	S	h	ℓ	Insert	Lever	Screw	Shim	Shim Pin	Wrench	Shim Pin Punch	
PDJNR/L	1616-H11N	16	16	100	20	16	DN□□ 1104□□	LV3AN	VHX0617N	SD32N	SP3	HW25L	LSPS3	
	2020-K11N	20	20	125	25	20								25
	2525-M11N	25	25	150	32	25								30
PDJNR/L	2020-K15N	20	20	125	25	20	DN□□ 1506□□	LV4BN	VHX0821N	SD42N	SP4N	HW30L	LSPS4	
	2525-M15N	25	25	150	32	25								35
	3225-P15N	32	25	170	32	32								35
	3232-P15N	32	32	170	40	32								35
PDJNR/L	2020-K15-3N	20	20	125	25	20	DN□□ 1504□□	LV4BN	VHX0821N	SD43N	SP4N	HW30L	LSPS4	
	2525-M15-3N	25	25	150	32	25								35
	3232-P15-3N	32	32	170	40	32								35

↻ Applicable inserts B36~B42

PDNNR/L

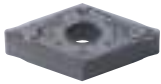

DN□□

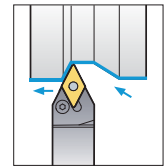
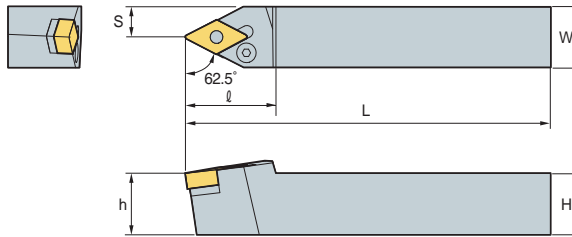

62.5°

• R type insert (mm)

Designation	H	W	L	S	h	ℓ	Insert	Lever	Screw	Shim	Shim Pin	Wrench	Shim Pin Punch	
PDNNR/L	2020-K15	20	20	125	8	20	DN□□ 1506□□	LV4B	VHX0821	SD42	SP4	HW30L	LSPS4	
	2525-M15	25	25	150	12.5	25								37
	3232-P15	32	32	150	16	32								37
	4025-M15	40	25	170	12.5	32	37	DN□□ 1504□□	LV4	VHX0821	SD42	SP4	HW30L	LSPS4
	2525-M15-3	25	25	150	12.5	25	37							
	4025-M15-3	40	25	150	12.5	25	37							
PDNNR/L	2020-K15N	20	20	125	8	20	DN□□ 1506□□	LV4BN	VHX0821N	SD42N	SP4N	HW30L	LSPS4	
	2525-M15N	25	25	150	12.5	25								37
	3232-P15N	32	32	170	16	32								37
	2525-M15-3N	25	25	150	12.5	25	37	DN□□ 1504□□	LV4BN	VHX0821N	SD43N	SP4N	HW30L	LSPS4
	3232-P15-3N	32	32	170	16	32	37							

↻ Applicable inserts B36~B42

B Lever Lock System

PRDCN



RCMX

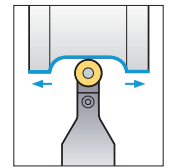
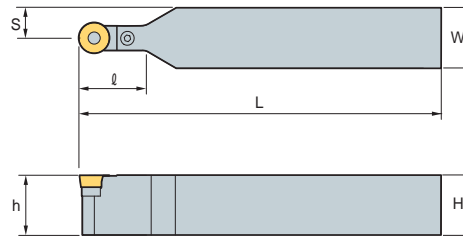

(mm)

Designation	H	W	L	S	h	l	Insert	Lever	Screw	Shim	Shim Pin	Wrench	Shim Pin Punch
PRDCN 2020-M10	20	20	150	10	20	24	RCMX 1003M0	LR10	VHX0514	SR10	SP3	HW20L	LSPS3
	25	25	150	12.5	25	24							
2525-M12	25	25	150	12.5	25	24	RCMX 1204M0	LR12	VHX0617	SR12	SP3	HW25L	LSPS3
2020-K12	20	20	125	10	20	24							
3225-Q12	32	25	180	12.5	32	24	RCMX 1606M0	LR16	VHX0621	SR16	SP4	HW25L	LSPS4
2525-Q16	25	25	180	12.5	25	30							
3225-Q16	32	25	180	12.5	32	30	RCMX 2006M0	LR20	VHX0823	SR20	SP20	HW30L	LSPS5
3232-Q16	32	32	180	16	32	35							
3232-Q20	32	32	180	16	32	40	RCMX 2507M0	LR25	VHX1030	SR25	SP6N	HW40L	LSPS6
4040-S25	40	40	250	20	40	42							
4040-T25	40	40	300	20	40	42	RCMX 3209M0	LR32	VHX1236	SR32	SP8N	HW50L	LSPS8
5050-U32	50	50	350	25	50	52							

Applicable inserts B74

PRGCR/L



RCMX

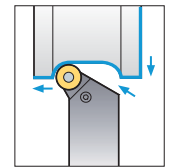
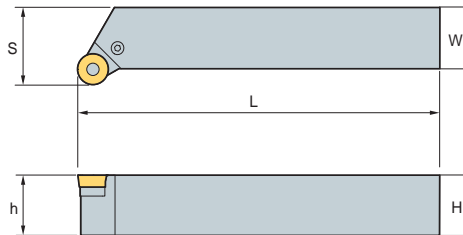

• R type insert
(mm)

Designation	H	W	L	S	h	Insert	Lever	Screw	Shim	Shim Pin	Wrench	Shim Pin Punch
PRGCR/L 2020-K10	20	20	125	25	20	RCMX 1003M0	LR10	VHX0514	SR10	SP3	HW20L	LSPS3
	25	25	150	32	25							
2020-K12	20	20	125	25	20	RCMX 1204M0	LR12	VHX0617	SR12	SP3	HW25L	LSPS3
2525-M12	25	25	150	32	25							
3225-P12	32	25	170	32	32	RCMX 1606M0	LR16	VHX0621	SR16	SP4	HW25L	LSPS4
2525-M16	25	25	150	32	25							
3225-P16	32	25	170	32	32	RCMX 2006M0	LR20	VHX0823	SR20	SP5-1	HW30L	LSPS5
3232-P20	32	32	170	40	32							
4040-S25	40	40	250	50	40	RCMX 2507M0	LR25	VHX1030	SR25	SP6N	HW40L	LSPS6

Applicable inserts B74



PSBNR/L

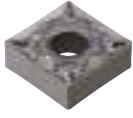

SN□□

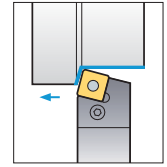
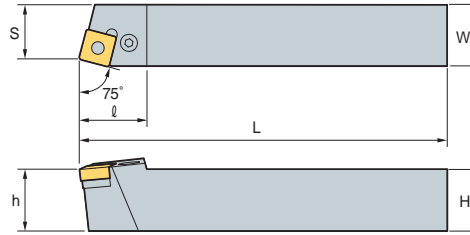

75°

• R type insert
(mm)

Designation	H	W	L	S	h	ℓ	Insert	Lever	Screw	Shim	Shim Pin	Wrench	Shim Pin Punch	
PSBNR/L	1616-H09	16	16	100	13	16	21	SN□□ 0903□□	LV3	VHX0617	SS32	SP3	HW25L	LSPS3
	2020-K09	20	20	125	17	20	23	SN□□ 1204□□	LV4	VHX0821	SS42	SP4	HW30L	LSPS4
	2020-K12	20	20	125	17	20	28							
	2525-M12	25	25	150	22	25	28							
	3225-P12	32	25	170	22	32	28							
	3232-P12	32	32	170	27	32	28	SN□□ 1506□□	LV5	VHX0825	SS53	SP5	HW30L	LSPS5
	2525-M15	25	25	150	22	25	35							
	3232-P15	32	32	170	27	32	35	SN□□ 1906□□	LV6N	VHX1027N	SS63N	SP6N	HW40L	LSPS6
	3232-P19	32	32	170	27	32	40							
	4040-S19	40	40	250	35	40	40	SN□□ 2507□□	LV8N	VHX1236N	SS84N	SP8N	HW50L	LSPS8
4040-S25	40	40	250	35	40	50								
4040-S25-6	40	40	250	35	40	50								
5050-T25	50	50	300	43	50	50								
5050-T25-6	50	50	300	43	50	46	SN□□ 2509□□							
PSBNR/L	1616-H09N	16	16	100	13	16	21	SN□□ 0903□□	LV3N	VHX0617N	SS32N	SP3	HW25L	LSPS3
	2020-K09N	20	20	125	17	20	23	SN□□ 1204□□	LV4N	VHX0820N	SS42N	SP4N	HW30L	LSPS4
	2020-K12N	20	20	125	17	20	28							
	2525-M12N	25	25	150	22	25	28							
	3225-P12N	32	25	150	22	25	28							
	3232-P12N	32	32	170	27	32	28	SN□□ 1506□□	LV5N	VHX0820AN	SS53N	SP5N	HW30L	LSPS5
	2525-M15N	25	25	150	22	25	35							

↻ Applicable inserts B44~B52

PSDNN



SN□□

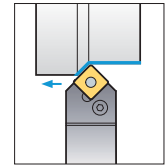
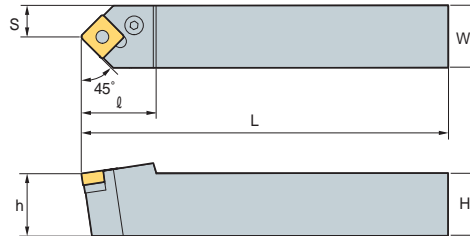

45°

(mm)

Designation	H	W	L	S	h	ℓ	Insert	Lever	Screw	Shim	Shim Pin	Wrench	Shim Pin Punch	
PSDNN	1616-H09	16	16	100	8	16	23	SN□□ 0903□□	LV3	VHX0617	SS32	SP3	HW25L	LSPS3
	2020-K12	20	20	125	10	20	30	SN□□ 1204□□	LV4	VHX0821	SS42	SP4	HW30L	LSPS4
	2525-M12	25	25	150	12.5	25	30							
	3225-P12	32	25	170	12.5	32	30							
	3232-P12	32	32	170	16	32	40							
	2525-M15	25	25	150	12.5	25	40	SN□□ 1506□□	LV5	VHX0825	SS53	SP5	HW30L	LSPS5
	3232-P15	32	32	170	16	32	40	SN□□ 1906□□	LV6N	VHX1027N	SS63N	SP6N	HW40L	LSPS6
	3225-P19	32	25	170	12.5	32	40							
	3232-P19	32	32	170	16	32	40	SN□□ 2507□□	LV8N	VHX1236N	SS84N	SP8N	HW50L	LSPS8
	4040-S19	40	40	250	20	40	40							
	4040-S25	40	40	250	20	40	50	SN□□ 2509□□	LV8N	VHX1236N	SS84N	SP8N	HW50L	LSPS8
	5050-T25	50	50	300	25	50	50							
	4040-S25-6	40	40	250	20	40	50	SN□□ 2509□□	LV8N	VHX1236N	SS84N	SP8N	HW50L	LSPS8
5050-T25-6	50	50	300	25	50	50								
PSDNN	1616-H09N	16	16	100	8	16	23	SN□□ 0903□□	LV3N	VHX0617N	SS32N	SP3	HW25L	LSPS3
	2020-K12N	20	20	125	10	20	30	SN□□ 1204□□	LV4N	VHX0820N	SS42N	SP4N	HW30L	LSPS4
	2525-M12N	25	25	150	12.5	20	30							
	3225-P12N	32	25	170	12.5	32	30							
	3232-P12N	32	32	170	16	32	40							
	2525-M15N	25	25	150	12.5	25	40	SN□□ 1506□□	LV5N	VHX0820AN	SS53N	SP5N	HW30L	LSPS5
	3232-P15N	32	32	170	16	32	40							

↻ Applicable inserts B44~B52

B Lever Lock System

PSKNR/L



SN□□

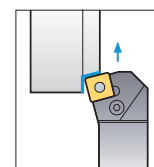
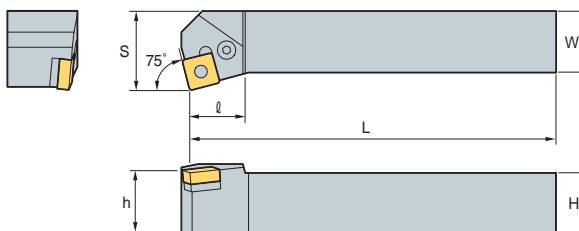

75°

• R type insert (mm)

Designation	H	W	L	S	h	l	Insert	Lever	Screw	Shim	Shim Pin	Wrench	Shim Pin Punch	
PSKNR/L	1616-H09	16	16	100	20	16	17	SN□□ 0903□□	LV3	VHX0617	SS32	SP3	HW25L	LSPS3
	2020-K09	20	20	125	25	20	20							
	2020-K12	20	20	125	25	20	23	SN□□ 1204□□	LV4	VHX0821	SS42	SP4	HW30L	LSPS4
	2525-M12	25	25	150	32	25	23							
	3232-P12	32	32	170	40	32	23	SN□□ 1506□□	LV5	VHX0825	SS53	SP5	HW30L	LSPS5
	2525-M15	25	25	150	32	25	28							
	3232-P15	32	32	170	40	32	28	SN□□ 1906□□	LV6N	VHX1027N	SS63N	SP6N	HW40L	LSPS6
	3232-P19	32	32	170	40	32	41.5							
	4040-S19	40	40	250	50	40	41.5	SN□□ 2507□□	LV8N	VHX1236N	SS84N	SP8N	HW50L	LSPS8
	4040-S25	40	40	250	50	40	46	SN□□ 2509□□	LV8N	VHX1236N	SS84N	SP8N	HW50L	LSPS8
4040-S25-6	40	40	250	50	40	46	SN□□ 2509□□	LV8N	VHX1236N	SS84N	SP8N	HW50L	LSPS8	
5050-T25-6	50	50	300	60	50	37.5	SN□□ 2509□□	LV8N	VHX1236N	SS84N	SP8N	HW50L	LSPS8	
PSKNR/L	1616-H09N	16	16	100	20	16	17	SN□□ 0903□□	LV3N	VHX0617N	SS32N	SP3	HW25L	LSPS3
	2020-K09N	20	20	125	25	20	20							
	2020-K12N	20	20	125	25	20	26	SN□□ 1204□□	LV4N	VHX0820N	SS42N	SP4N	HW30L	LSPS4
	2525-M12N	25	25	150	32	25	26							
	3232-P12N	32	32	170	40	32	26	SN□□ 1506□□	LV5N	VHX0820AN	SS53N	SP5N	HW30L	LSPS5
	2525-M15N	25	25	150	32	25	32							
	3232-P15N	32	32	170	40	32	32							

↻ Applicable inserts B44-B52

PSSNR/L



SN□□

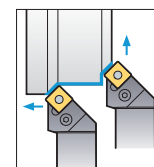
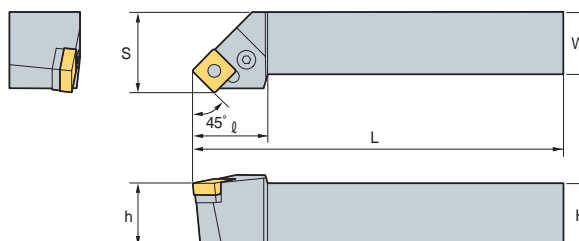

45°

• R type insert (mm)

Designation	H	W	L	S	h	l	Insert	Lever	Screw	Shim	Shim Pin	Wrench	Shim Pin Punch	
PSSNR/L	1616-H09	16	16	100	20	16	25	SN□□ 0903□□	LV3	VHX0617	SS32	SP3	HW25L	LSPS3
	2020-K12	20	20	125	25	20	30							
	2525-M12	25	25	150	32	25	36	SN□□ 1204□□	LV4	VHX0821	SS42	SP4	HW30L	LSPS4
	3225-P12	32	25	170	32	32	36							
	3232-P12	32	32	170	40	32	40	SN□□ 1506□□	LV5	VHX0825	SS53	SP5	HW30L	LSPS5
	2525-M15	25	25	150	32	25	36							
	3232-P15	32	32	170	40	32	45	SN□□ 1906□□	LV6N	VHX1027N	SS63N	SP6N	HW40L	LSPS6
	3232-P19	32	32	170	40	32	41.5							
	4040-R19	40	40	200	50	40	41.5	SN□□ 2507□□	LV8N	VHX1236N	SS84N	SP8N	HW50L	LSPS8
	4040-S19	40	40	250	50	40	41.5	SN□□ 2509□□	LV8N	VHX1236N	SS84N	SP8N	HW50L	LSPS8
4040-S25	40	40	250	50	40	48	SN□□ 2509□□	LV8N	VHX1236N	SS84N	SP8N	HW50L	LSPS8	
4040-S25-6	40	40	250	50	40	48								
PSSNR/L	1616-H09N	16	16	100	20	16	25	SN□□ 0903□□	LV3N	VHX0617N	SS32N	SP3	HW25L	LSPS3
	2020-K12N	20	20	125	25	20	30							
	2525-M12N	25	25	150	32	25	36	SN□□ 1204□□	LV4N	VHX0821N	SS42N	SP4N	HW30L	LSPS4
	3225-P12N	32	25	170	32	32	45							
	3232-P12N	32	32	170	40	32	40	SN□□ 1506□□	LV5N	VHX08209N	SS53N	SP5N	HW30L	LSPS5
	2525-M15N	25	25	150	32	25	36							
	3232-P15N	32	32	170	40	32	45							

↻ Applicable inserts B44-B52



PTFNR/L



TN□□

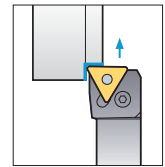
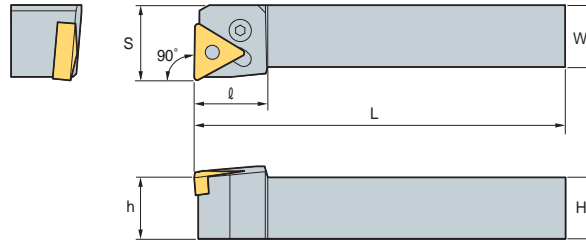

90°

• R type insert (mm)

Designation	H	W	L	S	h	ℓ	Insert	Lever	Screw	Shim	Shim Pin	Wrench	Shim Pin Punch	
PTFNR/L	1616-H16	16	16	100	20	16	TN□□1604□□	LV3	VHX0617	ST317	SP3	HW25L	LSPS3	
	2020-K16	20	20	125	25	20								20
	2525-M16	25	25	150	32	25								20
	2525-M22	25	25	150	32	25	TN□□2204□□	LV4	VHX0821	ST42	SP4	HW30L	LSPS4	
	3232-P22	32	32	170	40	32								25
	3232-P27	32	32	170	40	32	TN□□2706□□	LV5	VHX0825	ST53	SP5	HW30L	LSPS5	
	4040-S27	40	40	250	50	40								34
PTFNR/L	2525-M22N	25	25	150	32	25	TN□□2204□□	LV4N	VHX0820N	ST42N	SP4N	HW30L	LSPS4	
	3232-P22N	32	32	170	40	32	TN□□2204□□	LV4N	VHX0820N	ST42N	SP4N	HW30L	LSPS4	
	3232-P27N	32	32	170	40	32	TN□□2706□□	LV5AN	VHX0823N	ST53N	SP5N	HW30L	LSPS5	
	4040-S27N	40	40	250	50	40	TN□□2706□□	LV5AN	VHX0823N	ST53N	SP5N	HW30L	LSPS5	

↻ Applicable inserts B53~B59

PTGNR/L



TN□□

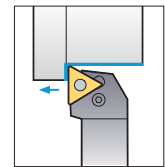
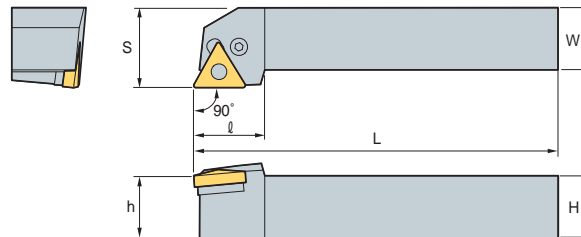

90°

• R type insert (mm)

Designation	H	W	L	S	h	ℓ	Insert	Lever	Screw	Shim	Shim Pin	Wrench	Shim Pin Punch	
PTGNR/L	1212-F11	12	12	80	16	12	TN□□1103□□	LV2	VHX0509B	-	-	HW20L	-	
	1616-H11	16	16	100	20	16								18
	2020-K11	20	20	125	25	20								19
	2525-M11	25	25	150	32	25	TN□□1604□□	LV3	VHX0617	ST317	SP3	HW25L	LSPS3	
	1616-H16	16	16	100	20	16								20
	2020-K16	20	20	125	25	20								20
	2525-M16	25	25	150	32	25								20
	3232-P16	32	32	170	40	32								20
	2525-M22	25	25	150	32	25								28
	3232-P22	32	32	170	40	32								28
3232-P27	32	32	170	40	32	33								
4040-S27	40	40	250	50	40	33								
PTGNR/L	2525-M22N	25	25	150	32	25	TN□□2204□□	LV4N	VHX0820N	ST42N	SP4N	HW30L	LSPS4	
	3232-P22N	32	32	170	40	32	TN□□2204□□	LV4N	VHX0820N	ST42N	SP4N	HW30L	LSPS4	
	3232-P27N	32	32	170	40	32	TN□□2706□□	LV5AN	VHX0823N	ST53N	SP5N	HW30L	LSPS5	
	4040-S27N	40	40	250	50	40	TN□□2706□□	LV5AN	VHX0823N	ST53N	SP5N	HW30L	LSPS5	

↻ Applicable inserts B53~B59

B Lever Lock System

PTTNR/L



TN□□

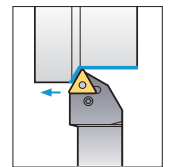
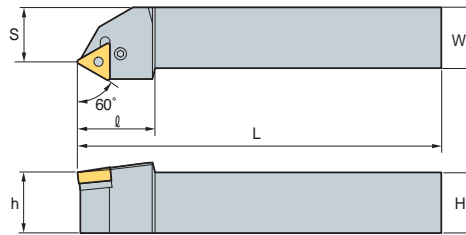

60°

• R type insert (mm)

Designation	H	W	L	S	h	ℓ	Insert	Lever	Screw	Shim	Shim Pin	Wrench	Shim Pin Punch						
PTTNR/L	1616-H16	16	16	100	13	16	TN□□1604□□												
	2020-K16	20	20	125	17	20								LV3	VHX0617	ST317	SP3	HW25L	LSPS3
	2525-M16	25	25	150	22	25								32	LV4	VHX0821	ST42	SP4	HW30L
PTTNR/L	2525-M22N	25	25	150	22	25	32	TN□□2204□□	LV4N	VHX0820N	ST42N	SP4N	HW30L	LSPS4					

Applicable inserts B53-B59

PWLNR/L



WN□□

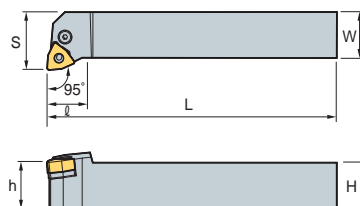

Fig.1

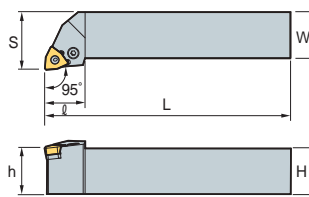
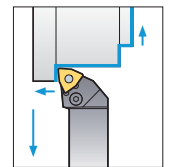

Fig.2



95°

• R type insert (mm)

Designation	H	W	L	S	h	ℓ	Insert	Lever	Screw	Shim	Shim Pin	Wrench	Shim Pin Punch	Fig.							
PWLNR/L	1616-H06	16	16	100	20	16	WN□□0604□□							1							
	2020-K06	20	20	125	25	20									LV3	VHX0617	SW317	SP3	HW25L	LSPS3	
	2525-M06	25	25	150	32	25									20	LV4	VHX0821	SW42	SP4	HW30L	LSPS4
	2020-K08	20	20	125	25	20									26	LV4	VHX0821	SW42	SP4	HW30L	LSPS4
PWLNR/L	1616-H06N	16	16	100	20	16	WN□□0604□□							1							
	2020-K06N	20	20	125	25	20									LV3N	VHX0617N	SW317N	SP3	HW25L	LSPS3	
	2525-M06N	25	25	150	32	25									20	LV4N	VHX0820N	SW42N	SP4N	HW30L	LSPS4
	2020-K08N	20	20	125	25	20									26	LV4N	VHX0820N	SW42N	SP4N	HW30L	LSPS4
PTTNR/L	2525-N08N	25	25	150	32	25	26	WN□□0804□□	LV4N	VHX0820N	SW42N	SP4N	HW30L	LSPS4							

Applicable inserts B62-B65



WTENN



TN□□

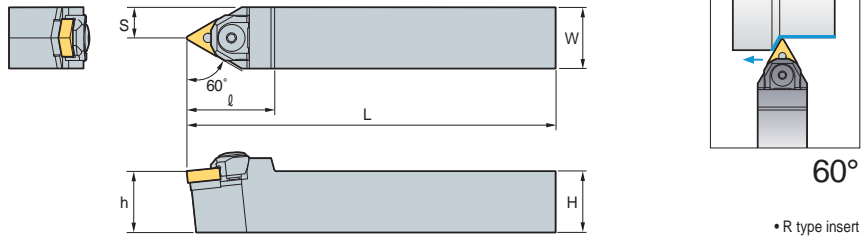

• R type insert (mm)

Designation	H	W	L	S	h	ℓ	Insert	Wedge Clamp	Screw	Stopper Ring	Shim	Shim Pin	Nut	Wrench			
WTENN	2020-K16	20	20	125	10	20	TN□□1604□□					SP3M-1					
	2525-M16	25	25	150	12.5	25						36			SP3M	N0407	HW30L
	2525-M22	25	25	150	12.5	25						42					
3232-P22	32	32	170	16	32	42	TN□□2204□□										
												SP4M	N0508	HW30L			

↻ Applicable inserts B53-B59

WTJNR/L



TN□□

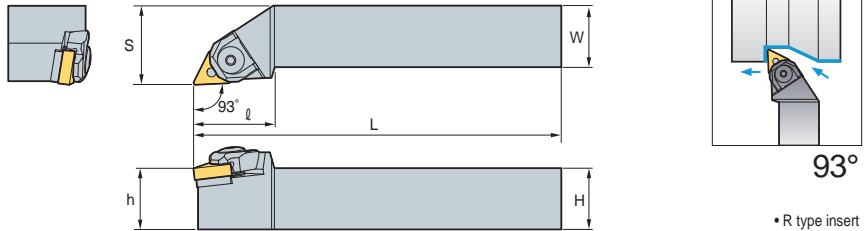

• R type insert (mm)

Designation	H	W	L	S	h	ℓ	Insert	Wedge Clamp	Screw	Stopper Ring	Shim	Shim Pin	Nut	Wrench			
WTJNR/L	2020-K16	20	20	125	25	20	TN□□1604□□					SP3M-1					
	2525-M16	25	25	150	32	25						33			SP3M	N0407	HW30L
	3232-P16	32	32	170	40	32						33					
	2525-M22	25	25	150	32	25						35					
	3232-P22	32	32	170	40	32						35			TN□□2204□□		
												SP4M	N0508	HW30L			

↻ Applicable inserts B53-B59

WTXNR/L



TN□□

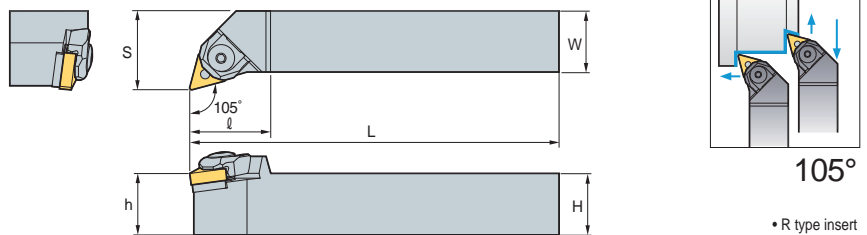

• R type insert (mm)

Designation	H	W	L	S	h	ℓ	Insert	Wedge Clamp	Screw	Stopper Ring	Shim	Shim Pin	Nut	Wrench			
WTXNR/L	2020-K16	20	20	125	25	20	TN□□1604□□					SP3M-1					
	2525-M16	25	25	150	32	25						33			SP3M	N0407	HW25L
	3232-P16	32	32	170	40	32						33					

↻ Applicable inserts B53-B59

B Wedge Clamp System

WWLNR/L



WN□□

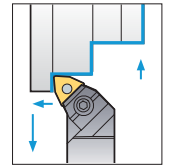
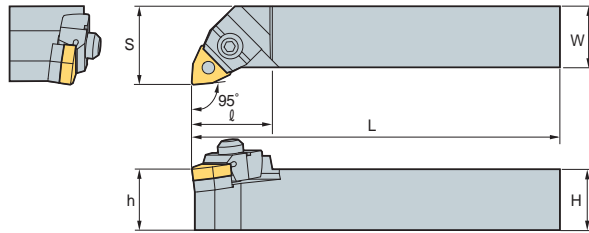

95°

• R type insert (mm)

Designation	H	W	L	S	h	ℓ	Insert	Wedge Clamp	Screw	Stopper Ring	Shim	Shim Pin	Nut	Wrench
WWLNR/L 2020-K08	20	20	125	25	20	32	WN□□0804□□	CMH6R/L3	MHX0630	CR05	SW43M	SP2M	N0508	HW30L HW40L
2525-M08	25	25	150	32	25	33		CMH6R2				SP4M		
3232-P08	32	32	170	40	32	33		CMH6R2						

↻ Applicable inserts **B62-B65**



CKJNR/L



KN□□

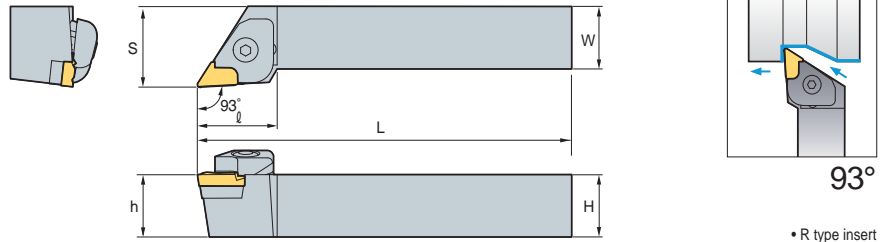

• R type insert (mm)

Designation		H	W	L	S	h	ℓ	Insert	Clamp	Clamp Screw	Spring	Shim	Pin + Spring	Shim Screw	Wrench
CKJNR	2020-K16	20	20	125	25	20	32	KN□□1604□□R							
	2525-M16	25	25	150	32	25	32								
	3225-M16	32	25	150	32	32	32								
	3225-P16	32	25	170	32	32	32								
	3232-P16	32	32	170	40	32	32								
4040-R16	40	40	200	50	40	32	CTH6R1	CHX0625	SR3	SK33C	PN0515 SR4	SHX0310	HW20L HW40L		
CKJNL	2020-K16	20	20	125	25	20	32	KN□□1604□□L							
	2525-M16	25	25	150	32	25	32								
	3232-P16	32	32	170	40	32	32								
	4040-R16	40	40	200	50	40	32								

➔ Applicable inserts B43

CKNNR/L



KN□□

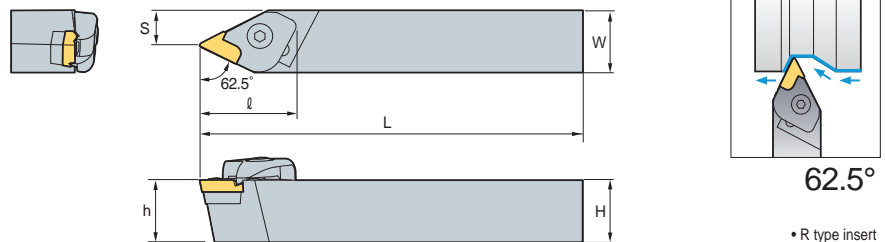

• R type insert (mm)

Designation		H	W	L	S	h	ℓ	Insert	Clamp	Clamp Screw	Spring	Shim	Pin + Spring	Shim Screw	Wrench
CKNNR	2525-M16	25	25	150	14.3	25	37	KN□□ 1604□□R							
	3232-P16	32	32	170	16.8	32	37								
CKNNL	2525-M16	25	25	150	14.3	25	37	KN□□ 1604□□L							
	3232-P16	32	32	170	16.8	32	37								

➔ Applicable inserts B43

CSDPN

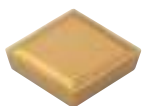

SP□R

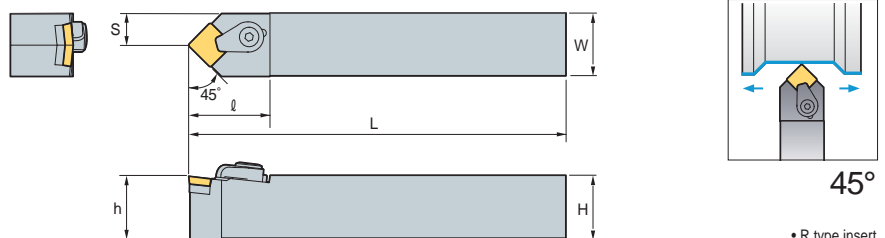

• R type insert (mm)

Designation		H	W	L	S	h	ℓ	Insert	Clamp	Clamp Screw	Shim	Shim Pin	C-Ring	Wrench
CSDPN	1616-H09	16	16	100	8	16	30	SP□R 0903□□						
	2525-M12	25	25	150	12.5	25	35	SP□R 1203□□						

➔ Applicable inserts B76~77

B Clamp on System

CSKPR/L

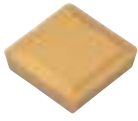

SP□R

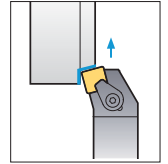
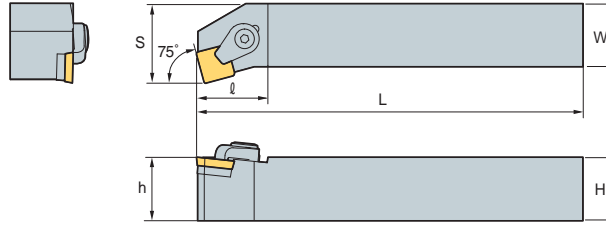

75°

• R type insert (mm)

Designation	H	W	L	S	h	ℓ	Insert	Clamp	Clamp Screw	Shim	Shim Pin	C-Ring	Wrench
CSKPR/L 2525-M12	25	25	150	32	20	32	SP□R 1203□□						

➔ Applicable inserts B76-B77

CTFPR/L



TP□R

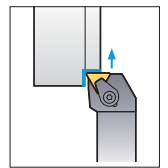
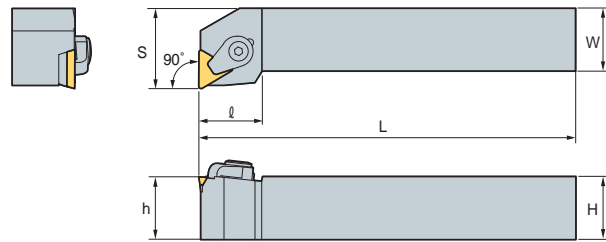

90°

• R type insert (mm)

Designation	H	W	L	S	h	ℓ	Insert	Clamp	Clamp Screw	Shim	Shim Pin	C-Ring	Wrench
CTFPR/L 2020-K16	25	25	125	25	20	32	TP□R 1603□□						
2525-M16	25	25	150	32	25	32							

➔ Applicable inserts B81-B83

CTGPR/L



TP□R

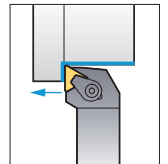
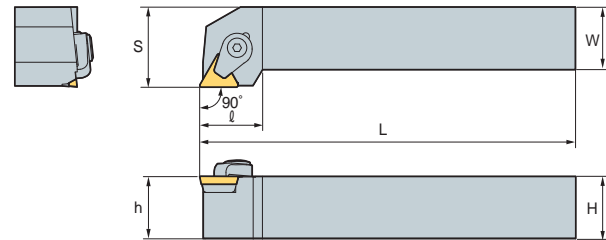

90°

• R type insert (mm)

Designation	H	W	L	S	h	ℓ	Insert	Clamp	Clamp Screw	Shim	Shim Pin	C-Ring	Wrench
CTGPR/L 1212-F11	12	12	80	16	12	20	TP□R 1103□□						
1616-H11	16	16	100	20	16	20							
2020-K11	20	20	125	25	20	20							
2020-K16	20	20	125	25	20	25	TP□R 1603□□						
2525-M16	25	25	150	32	25	25							
2525-M22	25	25	150	32	25	32	TP□R 2204□□						
3232-P22	32	32	170	40	32	32							

➔ Applicable inserts B81-B83



MCKNR/L



CN□□

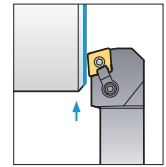
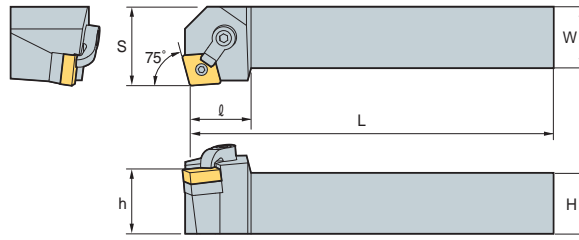

75°

• R type insert
(mm)

Designation	H	W	L	S	h	l	Insert	Clamp	Clamp Screw	Shim	Shim Pin	Wrench
MCKNR/L 2020-K12	20	20	125	25	20	32	CN□□1204□□	CDH6N	DHA1/4-25	SC43D	SP4D	HW31.8L HW23.8L
2525-M12	25	25	150	32	25	32						
3232-P12	32	32	170	40	32	32						

➔ Applicable inserts B28-B35

MCLNR/L

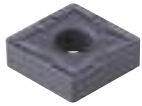

CN□□

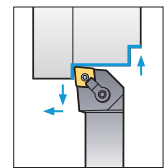
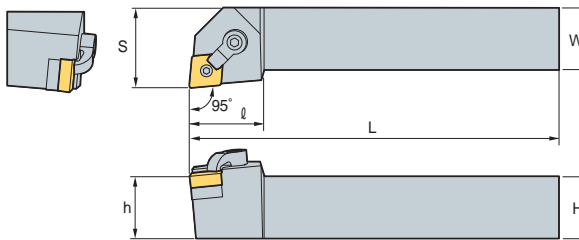

95°

• R type insert
(mm)

Designation	H	W	L	S	h	l	Insert	Clamp	Clamp Screw	Shim	Shim Pin	Wrench
MCLNR/L 1616-H09	16	16	100	20	16	25	CN□□0903□□	CDH7N	DHA10-32-19	SC32D	SP3DS	HW23.8L HW19.8L
2020-K09	20	20	125	25	20	25						
2525-M09	25	25	150	32	25	25						
2020-K12	20	20	125	25	20	32	CN□□1204□□	CDH6N	DHA1/4-25	SC43D	SP4D	HW31.8L HW23.8L
2525-M12	25	25	150	32	25	32						
3225-P12	32	25	170	32	32	32						
3232-P12	32	32	170	40	32	32	CN□□1606□□	CDH8N	DHA5/16-32	SC53D	SP5D	HW39.7L HW31.8L
2525-M16	25	25	150	32	25	33						
3232-P16	32	32	170	40	32	33						
4040-S16	40	40	250	50	40	33	CN□□1906□□	CDH8N	DHA5/16-32	SC63D	SP6D	HW39.7L HW35.7L
2525-M19	25	25	150	32	25	38						
3232-P19	32	32	170	40	32	38						
4040-S19	40	40	250	50	40	38	CN□□2507□□	CDH8N3	DHA3/8-35	SC84D	SP8D	HW39.7L HW47.6L
4040-S25	40	40	250	50	40	38						

➔ Applicable inserts B28-B35

MCMNN



CN□□

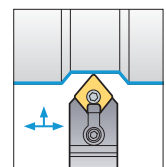
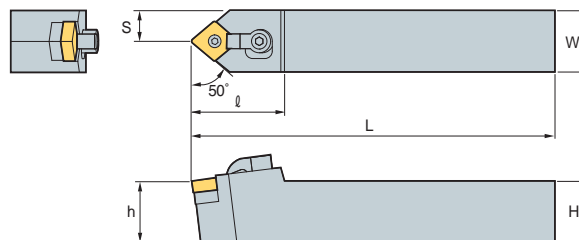

50°

• R type insert
(mm)

Designation	H	W	L	S	h	l	Insert	Clamp	Clamp Screw	Shim	Shim Pin	Wrench
MCMNN 2020-K12	20	20	125	10	20	32	CN□□1204□□	CDH6N	DHA1/4-25	SC43D	SP4D	HW31.8L HW23.8L
2525-M12	25	25	150	12.5	25	32						
3232-P12	32	32	170	16	32	32						
2525-M16	25	25	150	12.5	25	40	CN□□1606□□	CDH8N	DHA5/16-32	SC53D	SP5D	HW39.7L HW31.8L
3232-P16	32	32	170	16	32	40						
3232-P19	32	32	170	16	32	40						
4040-S19	40	40	250	20	40	32	CN□□1906□□	CDH8N	DHA5/16-32	SD63D	SP6D	HW39.7L HW35.7L

➔ Applicable inserts B28-B35



B Multi Lock System

MCRNR/L



CN□□

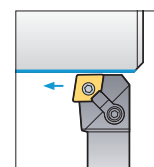
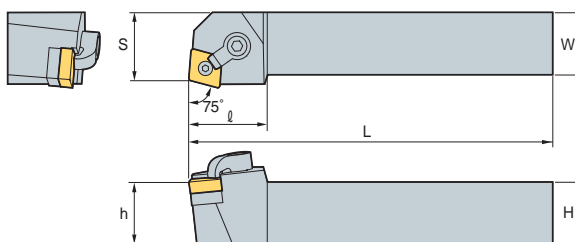

75°

• R type insert (mm)

Designation	H	W	L	S	h	ℓ	Insert	Clamp	Clamp Screw	Shim	Shim Pin	Wrench
MCRNR/L 2020-K12	20	20	125	22	20	32	CN□□1204□□					
	25	25	150	27	25	32						
2525-M16	25	25	150	27	25	33	CN□□1606□□					
3232-P16	32	32	170	35	32	33						
3232-P19	32	32	170	35	32	38	CN□□1906□□					
4040-S19	40	40	250	43	40	38						

➔ Applicable inserts B28-B35

MDJNR/L



DN□□

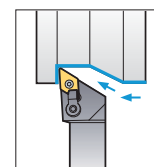
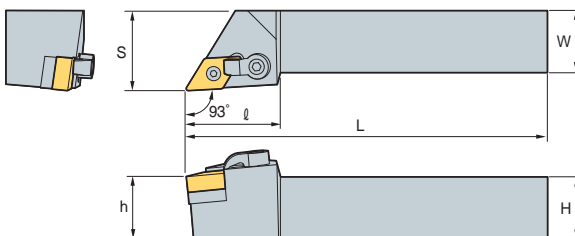

93°

• R type insert (mm)

Designation	H	W	L	S	h	ℓ	Insert	Clamp	Clamp Screw	Shim	Shim Pin	Wrench
MDJNR/L 2020-K11	20	20	125	25	20	32	DN□□1204□□					
	25	25	150	32	25	32						
2020-K15-3	20	20	125	25	20	36	DN□□1504□□					
2525-M15-3	25	25	150	32	25	36						
3232-P15-3	32	32	170	40	32	36	DN□□1506□□					
2020-K15	20	20	125	25	20	36						
2525-M15	25	25	150	32	25	36	DN□□1506□□					
3232-P15	32	32	170	40	32	36						

➔ Applicable inserts B36-B42

MDNNN



DN□□

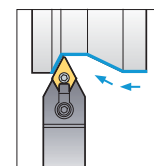
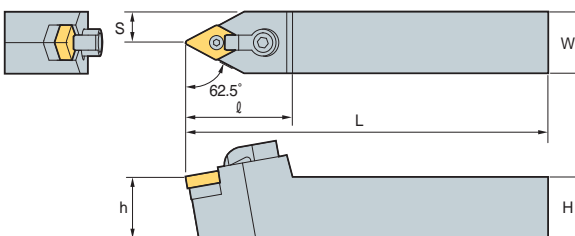

62.5°

(mm)

Designation	H	W	L	S	h	ℓ	Insert	Clamp	Clamp Screw	Shim	Shim Pin	Wrench
MDNNN 2525-M15-3	25	25	150	12.5	25	41	DN□□1504□□					
	25	25	150	12.5	25	41						
2525-M15	25	25	150	12.5	25	41	DN□□1506□□					
								CDH8N	DHA5/16-32	SD43D	SP4DL	HW39.7L HW23.8L

➔ Applicable inserts B36-B42



MDQNR/L



DN□□

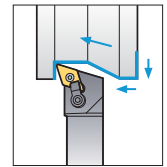
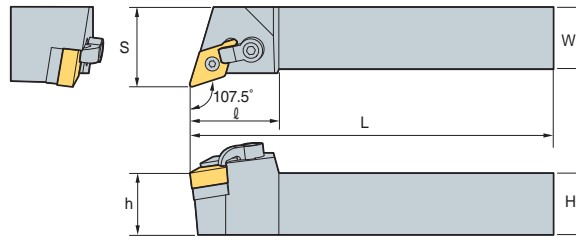

107.5°

• R type insert (mm)

Designation	H	W	L	S	h	ℓ	Insert	Clamp	Clamp Screw	Shim	Shim Pin	Wrench
MDQNR/L	2525-M15-3	25	25	150	32	25	DN□□1504□□					
	3232-P15-3	32	32	170	40	32						
	2525-M15	25	25	150	32	25	DN□□1506□□					
	3232-M15	32	32	170	40	32						

➔ Applicable inserts B36~B42

MSBNR/L



SN□□

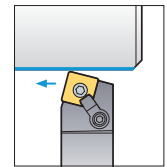
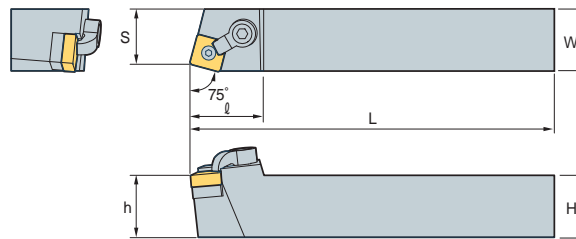

75°

• R type insert (mm)

Designation	H	W	L	S	h	ℓ	Insert	Clamp	Clamp Screw	Shim	Shim Pin	Wrench
MSBNR/L	2020-K12	20	20	125	17	20	SN□□1204□□					
	2525-M12	25	25	150	22	25						
	2525-M15	25	25	150	22	25	SN□□1506□□					
	3232-P15	32	32	170	22	32						
	3232-P19	32	32	170	27	32	SN□□1906□□					
	4040-S19	40	40	250	35	40						

➔ Applicable inserts B44~B52

MSDNN

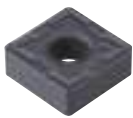

SN□□

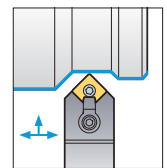
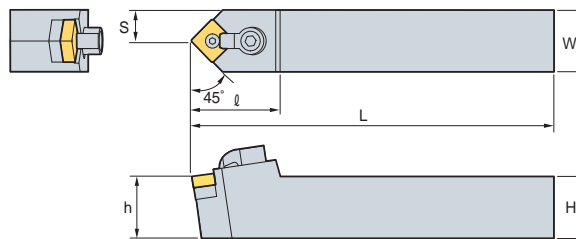

45°

(mm)

Designation	H	W	L	S	h	ℓ	Insert	Clamp	Clamp Screw	Shim	Shim Pin	Wrench
MSDNN	1616-H09	16	16	100	8	16	SN□□0903□□					
	2020-K09	20	20	125	10	20						
	2020-K12	20	20	125	10	20	SN□□1204□□					
	2525-M12	25	25	150	12.5	25						
	3225-P12	32	25	170	12.5	32	SN□□1506□□					
	2525-M15	25	25	150	12.5	25						
	3225-P15	32	25	170	12.5	32	SN□□1906□□					
	3232-P15	32	32	170	16	32						
	4040-S15	40	40	250	20	35	SN□□1906□□					
	3232-P19	32	32	170	16	32						
	4040-S19	40	40	250	20	42						

➔ Applicable inserts B44~B52

B Multi Lock System

MSKNR/L

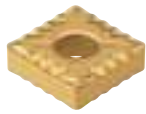

SN□□

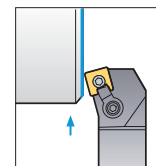
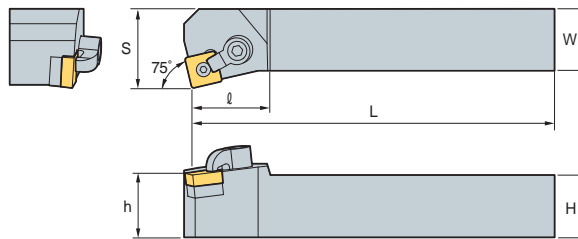

75°

• R type insert (mm)

Designation	H	W	L	S	h	l	Insert	Clamp	Clamp Screw	Shim	Shim Pin	Wrench
MSKNR/L 1616-H09	16	16	100	20	16	28	SN□□0903□□	CDH7N	DHA10-32-19	SS32D	SP3DS	HW19.8L HW23.8L
2020-K09	20	20	125	22	20	28						
2020-K12	20	20	125	25	20	32						
2525-M12	25	25	150	32	25	32	SN□□1204□□	CDH8N1	DHA5/16-32	SS43D	SP4D	HW39.7L HW23.8L
3225-P12	32	25	170	32	32	32						
2525-M15	25	25	150	32	25	35	SN□□1506□□	CDH8N	DHA5/16-32	SS53D	SP5D	HW39.7L HW31.8L
3232-P15	32	32	170	40	32	35						
3232-P19	32	32	170	40	32	40	SN□□1906□□	CDH8N	DHA5/16-32	SS63D	SP6D	HW39.7L HW35.7L
4040-S19	40	40	250	50	40	40						
4040-S25	40	40	250	50	40	40	SN□□2507□□	CDH8N3	DHA3/8-35	SS84D	SP8D	HW47.6L HW39.7L

➔ Applicable inserts B44-B52

MSRNR/L

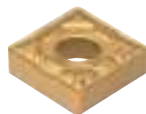

SN□□

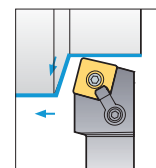
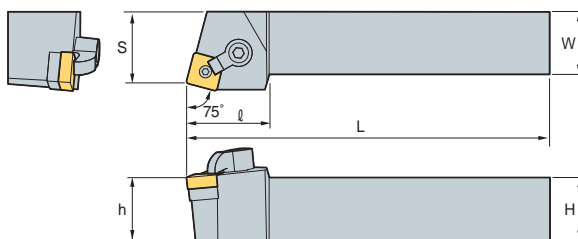

75°

• R type insert (mm)

Designation	H	W	L	S	h	l	Insert	Clamp	Clamp Screw	Shim	Shim Pin	Wrench
MSRNR/L 1616-H09	16	16	100	17	16	28	SN□□0903□□	CDH7N	DHA10-32-19	SS32D	SP3DS	HW19.8L HW23.8L
2020-K09	20	20	125	22	20	28						
2020-K12	20	20	125	22	20	32						
2525-M12	25	25	150	27	25	32	SN□□1204□□	CDH8N1	DHA5/16-32	SS43D	SP4D	HW39.7L HW23.8L
2525-M15	25	25	150	27	25	35						
3232-P15	32	32	170	35	32	35	SN□□1506□□	CDH8N	DHA5/16-32	SS53D	SP5D	HW39.7L HW31.8L
3225-P19	32	25	170	27	32	40						
3232-P19	32	32	170	35	32	40	SN□□1906□□	CDH8N	DHA5/16-32	SS63D	SP6D	HW39.7L HW35.7L
4040-S19	40	40	250	43	40	40						
4040-S25	40	40	250	43	40	40	SN□□2507□□	CDH8N3	DHA3/8-35	SS84D	SP8D	HW47.6L HW39.7L

➔ Applicable inserts B44-B52



MSSNR/L

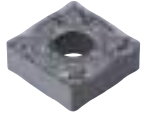

SN□□

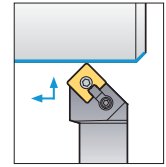
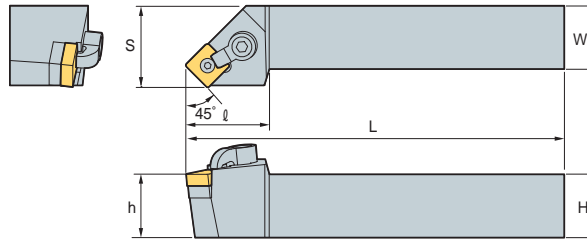

45°

• R type insert (mm)

Designation	H	W	L	S	h	ℓ	Insert	Clamp	Clamp Screw	Shim	Shim Pin	Wrench
MSSNR/L 1616-H09	16	16	100	20	16	28	SN□□0903□□					
	20	20	125	25	20	28						
2020-K12	20	20	125	25	20	32	SN□□1204□□					
2525-M12	25	25	150	32	25	32						
2525-M15	25	25	150	32	25	35	SN□□1506□□					
3232-P15	32	32	170	40	32	35						
3232-P19	32	32	170	40	32	40	SN□□1906□□					
4040-S19	40	40	250	50	40	40						

↻ Applicable inserts B44~B52

MTENN



TN□□

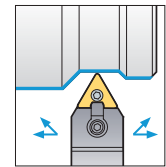
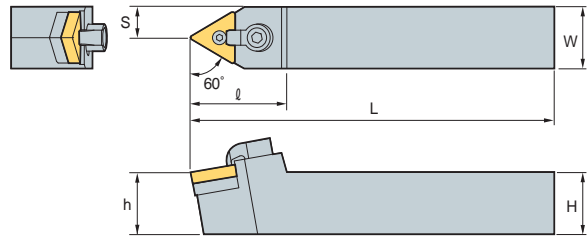

60°

(mm)

Designation	H	W	L	S	h	ℓ	Insert	Clamp	Clamp Screw	Shim	Shim Pin	Wrench
MTENN 2020-K16	20	20	125	10	20	32	TN□□1604□□					
	25	25	150	12.5	25	32						
2525-M22	25	25	150	12.5	25	35	TN□□2204□□					
3232-P27	32	32	170	16	32	35	TN□□2706□□					
4040-S33	40	40	250	20	40	40	TN□□3307□□					

↻ Applicable inserts B53~B59

MTFNR/L



TN□□

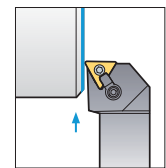
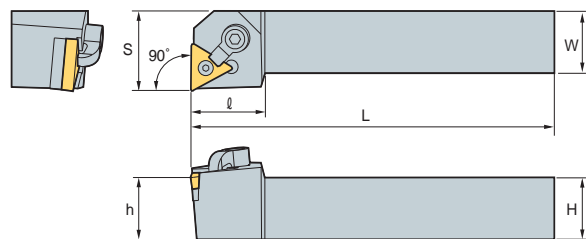

90°

• R type insert (mm)

Designation	H	W	L	S	h	ℓ	Insert	Clamp	Clamp Screw	Shim	Shim Pin	Wrench
MTFNR/L 1616-H16	16	16	100	20	16	32	TN□□1604□□					
	20	20	125	25	20	32						
2020-K16	20	20	125	25	20	32	TN□□2204□□					
2525-M16	25	25	150	32	25	32						
2525-M22	25	25	150	32	25	32	TN□□2706□□					
3232-P22	32	32	170	40	32	32						
4040-S22	40	40	250	50	40	32	TN□□2706□□					
3232-P27	32	32	170	40	32	35						
4040-S27	40	40	250	50	40	35	TN□□3307□□					
4040-S33	40	40	250	50	40	40						

↻ Applicable inserts B53~B59



B Multi Lock System

MTGNR/L



TN□□

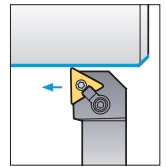
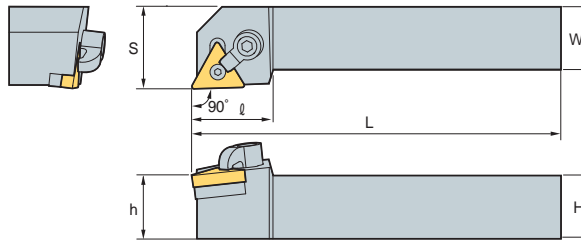

90°

• R type insert (mm)

Designation	H	W	L	S	h	ℓ	Insert	Clamp	Clamp Screw	Shim	Shim Pin	Wrench	
MTGNR/L	1616-H16	16	16	100	20	16	TN□□1604□□	CDH7N	DHA10-32-19	ST32D	SP3D	HW23.8L HW19.8L	
	2020-K16	20	20	125	25	20							32
	2525-M16	25	25	150	32	25							32
2525-M22	25	25	150	32	25	32	TN□□2204□□	CDH8N1	DHA5/16-32	ST43D	SP4D	HW39.7L HW23.8L	
3232-P22	32	32	170	40	32	32							
3232-P27	32	32	170	40	32	35	TN□□2706□□	CDH8N1	DHA5/16-32	ST53D	SP5D	HW39.7L HW31.8L	
4040-S27	40	40	250	50	40	35							
4040-S33	40	40	250	50	40	40	TN□□3307□□	CDH8N	DHA5/16-32	ST63D	SP6DL	HW39.7L HW35.7L	

➔ Applicable inserts B53-B59

MTJNR/L



TN□□

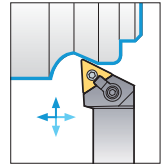
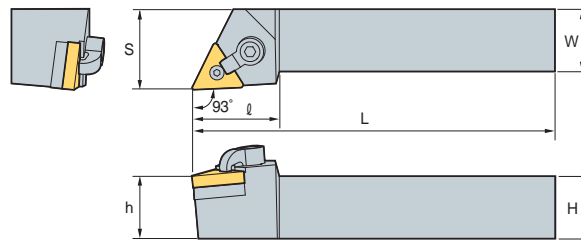

93°

• R type insert (mm)

Designation	H	W	L	S	h	ℓ	Insert	Clamp	Clamp Screw	Shim	Shim Pin	Wrench
MTJNR/L	2020-K16	20	20	125	25	20	TN□□1604□□	CDH7N	DHA10-32-19	ST32D	SP3D	HW23.8L HW19.8L
	2525-M16	25	25	150	32	25						
2525-M22	25	25	150	32	25	32	TN□□2204□□	CDH8N1	DHA5/16-32	ST43D	SP4D	HW39.7L HW23.8L
3232-P22	32	32	170	40	32	32						
3232-P27	32	32	170	40	32	35	TN□□2706□□	CDH8N1	DHA5/16-32	ST53D	SP5D	HW39.7L HW31.8L
4040-S27	40	40	250	50	40	35						
4040-S33	40	40	250	50	40	40	TN□□3307□□	CDH8N	DHA5/16-32	ST63D	SP6DL	HW39.7L HW35.7L

➔ Applicable inserts B53-B59

MVJNR/L



VN□□

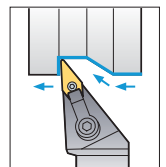
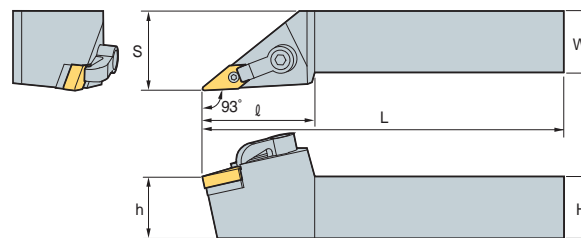

93°

• R type insert (mm)

Designation	H	W	L	S	h	ℓ	Insert	Clamp	Clamp Screw	Shim	Shim Pin	Wrench	
MVJNR/L	2020-K16	20	20	125	25	20	VN□□1604□□	CDH8N2	DHA5/16-32	SV32D	SP3D	HW39.7L HW19.8L	
	2525-M16	25	25	150	32	25							37
	3232-P16	32	32	170	40	32							37
2525-M22	25	25	150	32	25	50	VN□□2204□□	CDH8N2	DHA5/16-32	SV43D	SP4D	HW39.7L HW23.8L	
3232-P22	32	32	170	40	32	50							
4040-S22	40	40	250	50	40	50							

➔ Applicable inserts B60-B61



MVQNR/L



VN□□

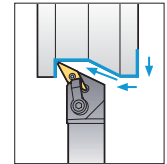
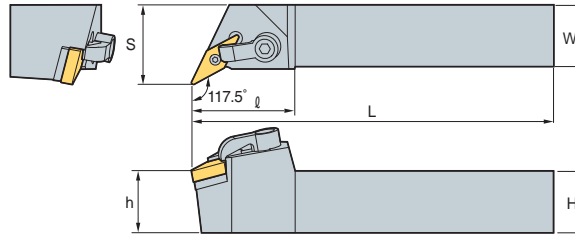

117.5°

• R type insert (mm)

Designation	H	W	L	S	h	ℓ	Insert	Clamp	Clamp Screw	Shim	Shim Pin	Wrench
MVQNR/L 2020-K16	20	20	125	25	20	42	VN□□1604□□					
2525-M16	25	25	150	32	25	42						
3232-P16	32	32	170	40	32	37						

↻ Applicable inserts B60-B61

MVVNN



VN□□

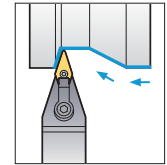
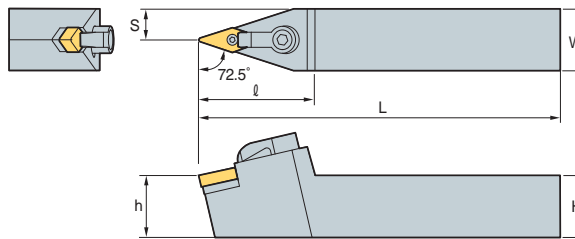

72.5°

(mm)

Designation	H	W	L	S	h	ℓ	Insert	Clamp	Clamp Screw	Shim	Shim Pin	Wrench
MVVNN 2020-K16	20	20	125	25	20	42	VN□□1604□□					
2525-M16	25	25	150	32	25	42						

↻ Applicable inserts B60-B61

MWLNR/L



WN□□

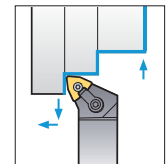
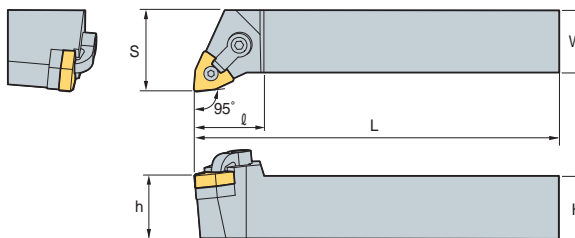

95°

• R type insert (mm)

Designation	H	W	L	S	h	ℓ	Insert	Clamp	Clamp Screw	Shim	Shim Pin	Wrench
MWLNR/L 2020-K06	20	20	125	25	20	32	WN□□0604□□					
2525-M06	25	25	150	32	25	32						
3232-P06	32	32	170	40	32	32						
2020-K08	20	20	125	25	20	32	WN□□0804□□					
2525-M08	25	25	150	32	25	32						
3232-P08	32	32	170	40	32	32						

↻ Applicable inserts B62-B65

B Screw on System

SCACR/L



CC□□

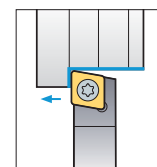
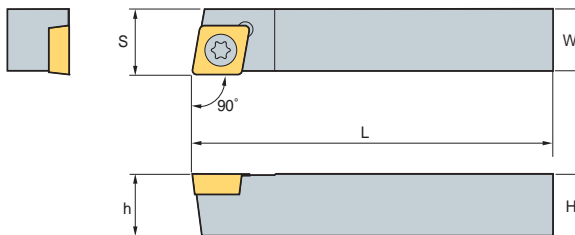

90°

• R type insert (mm)

Designation	H	W	L	S	h	Insert	Screw	Shim	Shim Screw	Wrench
SCACR/L 1010-E06	10	10	70	10.5	10	CC□□0602□□	FTKA02565	-	-	TW07P
1212-F09	12	12	80	12.5	12	CC□□09T3□□	FTKA03508	-	-	TW15P

➔ Applicable inserts B66~B69, B91

SCLCR/L



CC□□

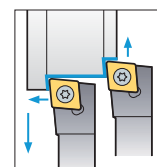
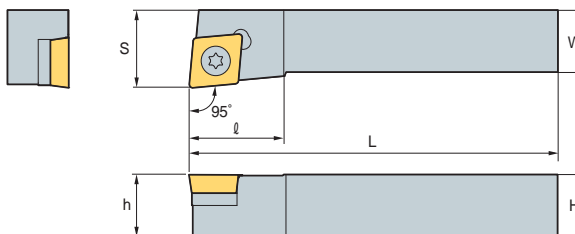

95°

• R type insert (mm)

Designation	H	W	L	S	h	ℓ	Insert	Screw	Shim	Shim Screw	Wrench
SCLCR/L 0808-D06	08	08	60	10	08	10	CC□□0602□□	FTKA02565	-	-	TW07P
1010-E06	10	10	70	16	10	10					
1212-F09	12	12	80	20	12	16					
1616-H09	16	16	100	20	16	16	CC□□09T3□□	CDH7N	-	-	TW15P
2020-K09	20	20	125	25	20	16					
2020-K12	20	20	125	25	20	25	CC□□1204□□	FTGA0411F	SC42S	SHXN0610F	TW15P
2525-M09	25	25	150	32	25	26	CC□□09T3□□	FTGA03508	-	-	TW15P
2525-M12	25	25	150	32	25	26	CC□□1204□□	FTGA0411F	SC42S	SHXN0610F	HW40L

➔ Applicable inserts B66~B69, B91

SDACR/L



DC□□

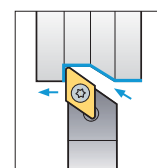
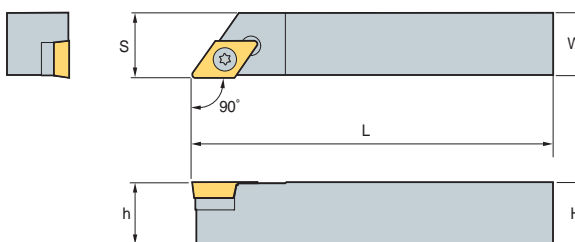

90°

• R type insert (mm)

Designation	H	W	L	S	h	Insert	Screw	Shim	Shim Screw	Wrench
SDACR/L 1010-E07	10	10	70	10.5	10	DC□□0702□□	FTKA02565	-	-	TW07P
1212-F11	12	12	80	12.5	12	DC□□11T3□□	FTKA03508	-	-	TW15P
1616-H11	16	16	100	16.5	16		FTGA03512	SD32S	SHXN0509F	TW15P, HW35L

➔ Applicable inserts B71~B73, B92



SDJCR/L



DC□□

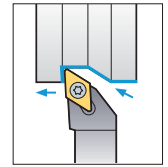
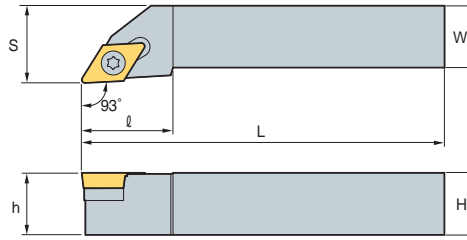

93°

• R type insert (mm)

Designation	H	W	L	S	h	ℓ	Insert	Screw	Shim	Shim Screw	Wrench
SDJCR/L	1010-E07	10	10	70	12	10	DC□□0702□□	FTKA02565	-	-	TW07P
	1212-F07	12	12	80	16	12					
	1616-H07	16	16	100	20	16					
	2020-K07	20	20	125	25	20					
SDJCR/L	1212-F11	12	12	80	16	12	DC□□11T3□□	FTGA03512	-	-	TW15P, HW35L
	1616-H11	16	16	100	20	16					
	2020-K11	20	20	125	25	20					
	2525-M11	25	25	150	32	25					

➔ Applicable inserts B71~B73, B92

SDNCN



DC□□

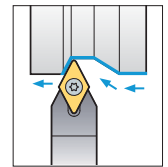
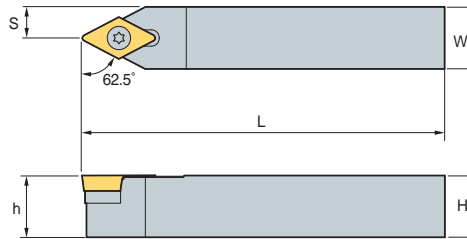

62.5°

(mm)

Designation	H	W	L	S	h	Insert	Screw	Shim	Shim Screw	Wrench	
SDNCN	1010-E07	10	10	70	5	10	DC□□0702□□	FTKA02565	-	-	TW07P
	1212-F07	12	12	80	6	12					
	1212-H11	12	12	100	6	12	DC□□11T3□□	FTGA03508	-	-	TW15P
	1616-H11	16	16	100	8	16	DC□□11T3□□	FTGA03512	SD32S	SHXN0509F	TW15P, HW35L
	2020-K11	20	20	125	10	20	DC□□11T3□□	FTGA03512	SD32S	SHXN0509F	TW15P, HW35L
	2020-M11	25	25	150	12.5	25	DCMT□□11T3□□	FTGA03512	SD32S	SHXN0509F	TW25P, HW35L

➔ Applicable inserts B71~B73, B92

SRDCN



RCGT

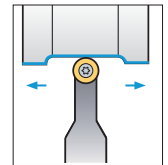
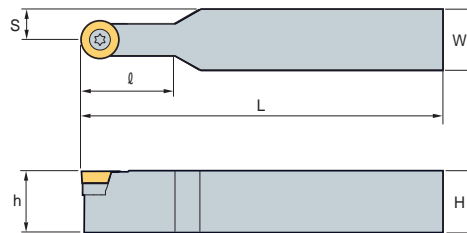

(mm)

Designation	H	W	L	S	h	ℓ	Insert	Screw	Shim	Shim Screw	Wrench
SRDCN	1010-E06	10	10	70	5	10	RCGT 0602M0	FTKA02565	-	-	TW07P
	1212-F06	12	12	80	6	12					
	1616-H06	16	16	100	8	16					
	2525-M06	25	25	150	12.5	25					
	1616-H08	16	16	100	8	16	RCGT 0803M0	FTNA0307	-	-	TW09P
	2020-K08	20	20	125	10	20					
	2525-M08	25	25	150	12.5	25					
	1616-H10	16	16	100	8	16	RCGT 1003M0	FTKA03511A	SR10S	SHXN0509F	TW15P, HW35L
	2020-K10	20	20	125	10	20					
	2525-M10	25	25	150	12.5	25					
	2020-K12	20	20	125	10	20					
	2525-M12	25	25	150	12.5	25					
2525-M12	25	25	150	12.5	25	RCGT 1204M0					

➔ Applicable inserts B93



B Screw on System

SRGCR/L



RCYT

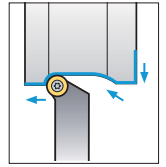
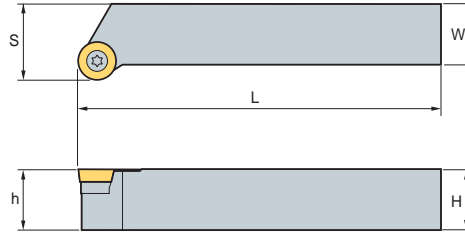

• R type insert
(mm)

Designation	H	W	L	S	h	Insert	Screw	Shim	Shim Screw	Wrench
SRGCR/L	1010-E06	10	10	70	12	RCYT 0602M0	FTKA02565	-	-	TW07P
	1212-F06	12	12	80	16					
	1616-H06	16	16	100	20					
SRGCR/L	1616-H08	16	16	100	20	RCYT 0803M0	FTNA0307	-	-	TW09P
	2020-K08	20	20	125	25					
	2525-M08	25	25	150	32					
SRGCR/L	1616-H10	16	16	100	20	RCYT 1003M0	FTKA03511A	SR10S	SHXN0509F	TW15P HW35L
	2020-K10	20	20	125	25					
	2525-M10	25	25	150	32					
SRGCR/L	2020-K12	20	20	125	25	RCYT 1204M0	FTGA03512	SR12S	SHXN0509F	TW15P HW35L
	2525-M12	25	25	150	32					

➔ Applicable inserts B93

SSBCR/L



SC□□

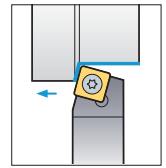
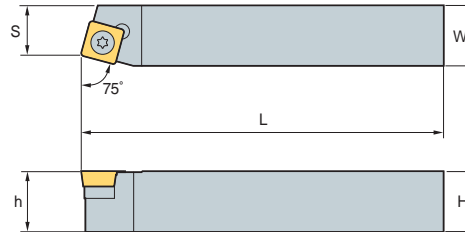

75°

• R type insert
(mm)

Designation	H	W	L	S	h	Insert	Screw	Shim	Shim Screw	Wrench
SSBCR/L	1212-F09	12	12	80	11	SC□□09T3□□	FTGA03508	-	-	TW15P
	1616-H09	16	16	100	13					
	2020-K12	20	20	125	17					
SSBCR/L	2020-K12	20	20	125	17	SC□□1204□□	FTGA0411F	SS42S	SHXN0610F	TW15P, HW40L

➔ Applicable inserts B74–B75, B94

SSDCN



SC□□

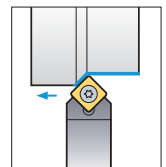
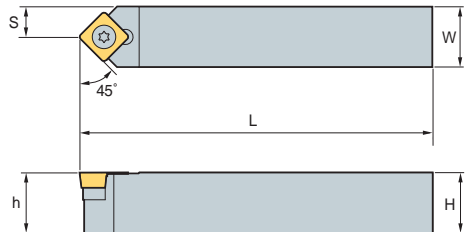

45°

(mm)

Designation	H	W	L	S	h	Insert	Screw	Shim	Shim Screw	Wrench
SSDCN	1212-F09	12	12	80	6	SC□□09T3□□	FTGA03508	-	-	TW15P
	1616-H09	16	16	100	8					
SSDCN	1616-H09	16	16	100	8	SC□□09T3□□	FTGA03512	SS32S	SHXN0509F	TW15P, HW35L

➔ Applicable inserts B74–B75, B94



SSKCR/L



SC□□

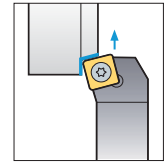
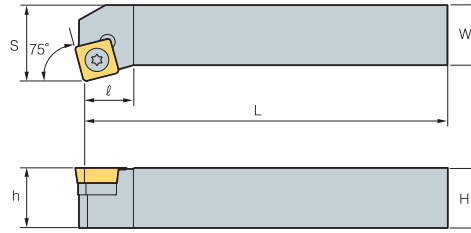

75°

• R type insert (mm)

Designation	H	W	L	S	h	ℓ	Insert	Screw	Shim	Shim Screw	Wrench
SSKCR/L 1616-H09	16	16	100	20	16	13	SC□□09T3□□	FTGA03512	SS32S	SHXN0509F	TW15P, HW35L

➔ Applicable inserts B74-B75, B94

SSSCR/L



SC□□

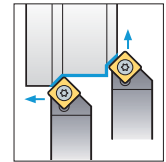
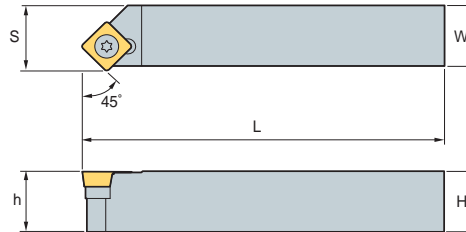

45°

• R type insert (mm)

Designation	H	W	L	S	h	Insert	Screw	Shim	Shim Screw	Wrench
SSSCR/L 1616-H09	16	16	100	17	16	SC□□09T3□□	FTGA03512	SS32S	SHXN0509F	TW15P, HW35L
2020-K12	20	20	125	21	20	SC□□1204□□	FTGA0411F	SS42S	SHXN0610F	TW15P, HW40L
2525-M12	25	25	150	26	25	SC□□1204□□	FTGA0411F	SS42S	SHXN0610F	TW15P, HW40L

➔ Applicable inserts B74-B75, B94

STACR/L



TC□□

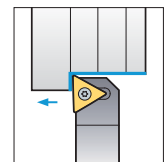
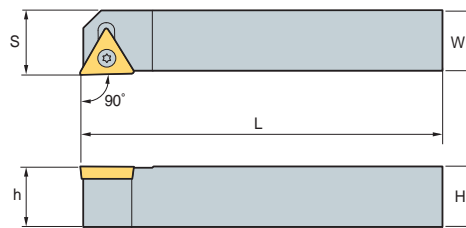

90°

• R type insert (mm)

Designation	H	W	L	S	h	Insert	Screw	Shim	Shim Screw	Wrench
STACR/L 1010-E09	10	10	70	10.5	10	TC□□0902□□	FTKA02206	-	-	TW06P
1212-F11	12	12	80	12.5	12	TC□□1102□□	FTKA02565	-	-	TW07P

➔ Applicable inserts B79-B80, B95

B Screw on System

STFCR/L



TC□□

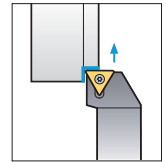
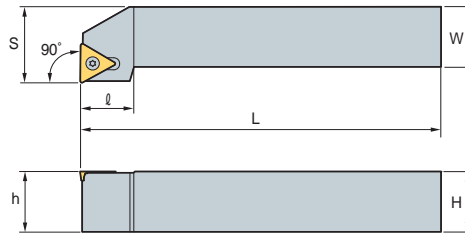

90°

• R type insert (mm)

Designation	H	W	L	S	h	ℓ	Insert	Screw	Shim	Shim Screw	Wrench
STFCR/L 1010-E09	10	10	70	12	10	10	TC□□0902□□	FTKA02206	-	-	TW06P
1212-F11	12	12	80	16	12	14	TC□□1102□□	FTKA02565	-	-	TW07P
1616-H11	16	16	100	20	16	14					
1616-H16	16	16	100	20	16	19	TC□□16T3□□	FTGA03512	ST32S	SHXN0509F	TW15P, HW35L
2020-K16	20	20	125	25	20	19					
2525-M16	25	25	150	32	25	25.2					

➔ Applicable inserts B79~B80, B95

STGCR/L



TC□□

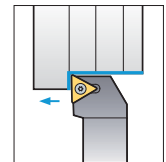
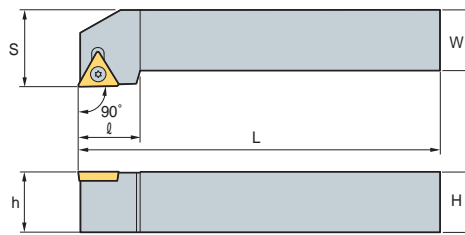

90°

• R type insert (mm)

Designation	H	W	L	S	h	ℓ	Insert	Screw	Shim	Shim Screw	Wrench
STGCR/L 0808-D09	08	08	60	10	08	11	TC□□0902□□	FTKA02206	-	-	TW06P
1010-E09	10	10	70	12	10	11					
1212-F11	12	12	80	16	12	14	TC□□1102□□	FTKA02565	-	-	TW07P
1616-H11	16	16	100	20	16	16					
1616-H16	16	16	100	20	16	21	TC□□16T3□□	FTGA03512	ST32S	SHXN0509F	TW15P, HW35L
2020-K16	20	20	125	25	20	21					
2525-M16	25	25	150	32	25	21					

➔ Applicable inserts B79~B80, B95

STTCR/L



TC□□

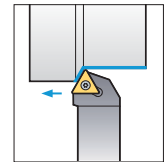
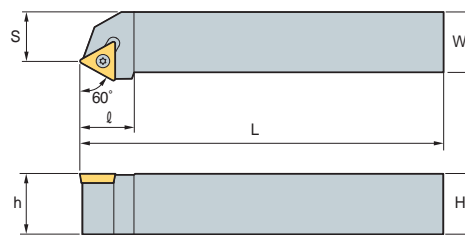

60°

• R type insert (mm)

Designation	H	W	L	S	h	ℓ	Insert	Screw	Shim	Shim Screw	Wrench
STTCR/L 1616-H11	16	16	100	13	16	14	TC□□1102□□	FTKA02565	-	-	TW07P
1616-H16	16	16	100	13	16	19					
2020-K16	20	20	125	17	20	19	TC□□16T3□□	FTGA03512	ST32S	SHXN0509F	TW15P, HW35L

➔ Applicable inserts B79~B80, B95



SVABR/L



VB□□

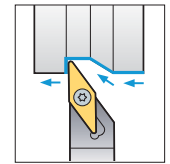
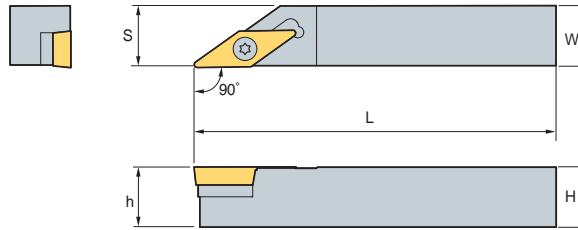

90°

• R type insert (mm)

Designation	H	W	L	S	h	Insert	Screw	Shim	Shim Screw	Wrench
SVABR/L 1616-H16	16	16	100	16.5	16	VB□□1604□□	FTGA03512	SV32S	SHXN0509F	TW15P, HW35L
2020-K16	20	20	125	20.5	20					

➔ Applicable inserts B84~B85, B96

SVHBR/L



VB□□

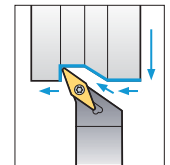
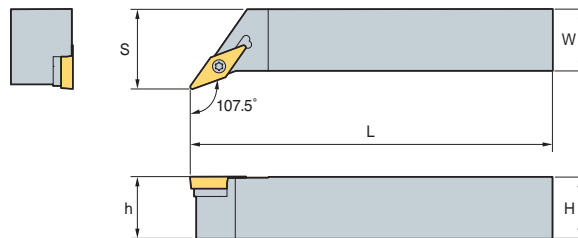

107.5°

• R type insert (mm)

Designation	H	W	L	S	h	Insert	Screw	Shim	Shim Screw	Wrench
SVHBR/L 2525-M16	25	25	150	32	25	VB□□1604□□	FTGA03512	SV32S	SHXN0509F	TW15P, HW35L
3225-P16	32	25	170	32	32					

➔ Applicable inserts B84~B85, B96

SVJBR/L



VB□□

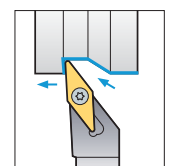
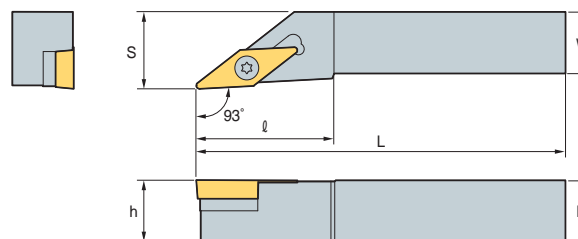

93°

• R type insert (mm)

Designation	H	W	L	S	h	ℓ	Insert	Screw	Shim	Shim Screw	Wrench
SVJBR/L 1212-F11	12	12	80	16	12	27	VB□□1102□□	FTKA02565	-	-	TW07P
1616-H11	16	16	100	20	16	27					
2020-K11	20	20	125	25	20	27					
1616-H16	16	16	100	20	16	36	VB□□1604□□	FTGA03512	SV32S	SHXN0509F	TW15P, HW35L
2020-K16	20	20	125	25	20	41					
2525-M16	25	25	150	32	25	41	VB□□1604□□	FTGA03512	SV32S	SHXN0509F	TW15P, HW35L
3225-P16	32	25	170	32	32	55					
3232-P16	32	32	170	40	33	55					

➔ Applicable inserts B84~B85, B96



B Screw on System

SVJCR/L



VC□□

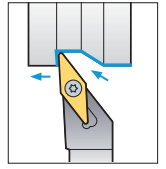
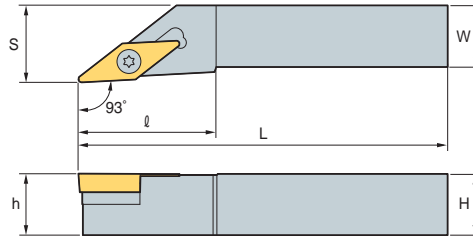

93°

• R type insert (mm)

Designation	H	W	L	S	h	ℓ	Insert	Screw	Shim	Shim Screw	Wrench	
SVJCR/L	1212-F11	12	12	80	16	12	VC□□1103□□	FTKA02565	-	-	TW07P	
	1616-H11	16	16	100	20	16						25
	2020-K11	20	20	125	25	20						25
	1212-F13	12	12	80	16	12	VC□□1303□□	FTKA0307	-	-	TW09P	
	1616-H13	16	16	100	20	16						32
	2020-K13	20	20	125	25	20						32
	1616-H16	16	16	100	20	16	VC□□1604□□	FTGA03512	SV32S	SHXN0509F	TW15P, HW35L	
	2020-K16	20	20	125	25	20						40
	2525-M16	25	25	150	32	25						

⇒ Applicable inserts B86~B87, B97

SVVBN



VB□□

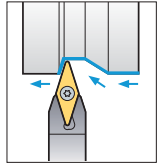
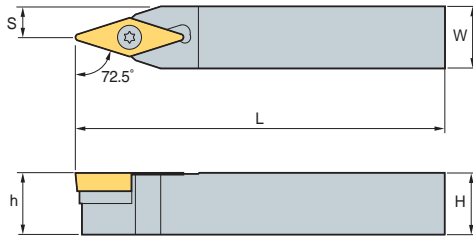

72.5°

(mm)

Designation	H	W	L	S	h	Insert	Screw	Shim	Shim Screw	Wrench	
SVVBN	1212-F11	12	12	80	6	12	VB□□1102□□	FTKA02565	-	-	TW07P
	1616-H11	16	16	100	8	16					
	2020-K11	20	20	125	10	20					
	1616-H16	16	16	100	8	16	VB□□1604□□	FTGA03512	SV32S	SHXN0509F	TW15P, HW35L
	2020-K16	20	20	125	10	20					
	2525-M16	25	25	150	12.5	25					
	3225-P16	32	25	170	12.5	32					

⇒ Applicable inserts B84~B85, B96

SVVCN



VC□□

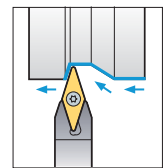
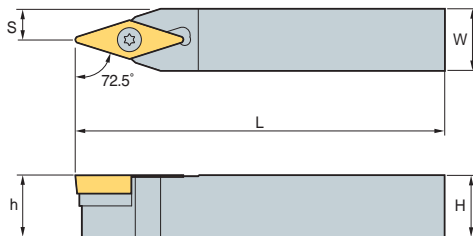

72.5°

(mm)

Designation	H	W	L	S	h	Insert	Screw	Shim	Shim Screw	Wrench	
SVVCN	1212-F11	12	12	80	6	12	VC□□1103□□	FTKA02565	-	-	TW07P
	1616-H11	16	16	100	8	16					
	2020-K11	20	20	125	10	20					
	1212-F13	12	12	80	6	12	VC□□1303□□	FTNA0307	-	-	TW09P
	1616-H13	16	16	100	8	16					
	2020-K13	20	20	125	10	20					
	1616-H16	16	16	100	8	16	VC□□1604□□	FTGA03512	SV32S	SHXN0509F	TW15P, HW35L
	2020-K16	20	20	125	10	20					
	2525-M16	25	25	150	12.5	25					

⇒ Applicable inserts B86~B87, B97



B

Turning

CCLNR/L



CN□N

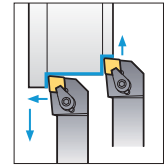
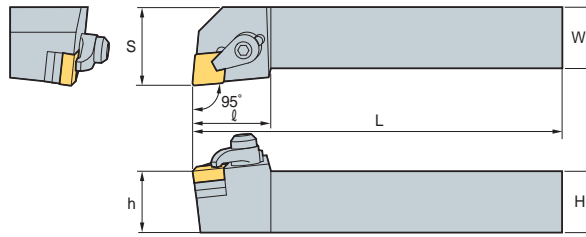

95°

• R type insert (mm)

Designation	H	W	L	S	h	ℓ	Insert	Clamp	Screw	Shim	Spring	Wrench
CCLNR/L 2525-M12C	25	25	150	32	25	32	CN□N 1204□□ 1207□□	CH6R3	MHX0630 SHX0310	SC42CC	SR3	HW40L HW20L

CRDNN



RN□N

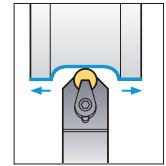
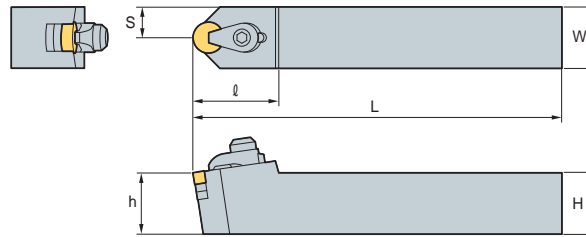

(mm)

Designation	H	W	L	S	h	ℓ	Insert	Clamp	Screw	Shim	Spring	Wrench
CRDNN 2525-M12C	25	25	150	12.5	25	35	RN□N 1204□□ 1207□□	CH6R3	MHX0630 SHX0310	SC42CC	SR3	HW40L HW20L

CRGNR/L



RN□N

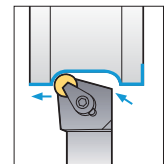
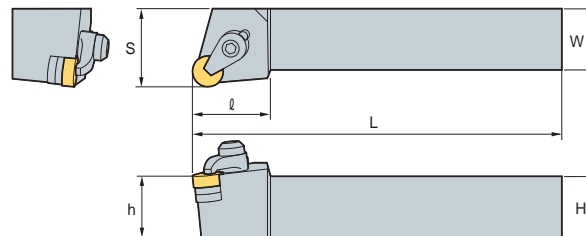

• R type insert (mm)

Designation	H	W	L	S	h	ℓ	Insert	Clamp	Screw	Shim	Spring	Wrench
CRGNR/L 2525-M12C	25	25	150	32	25	32	RN□N 1204□□ 1207□□	CH6R3	MHX0630 SHX0310	SC42CC	SR3	HW40L HW20L

CSDNN



SN□N

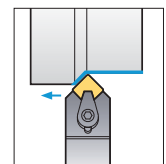
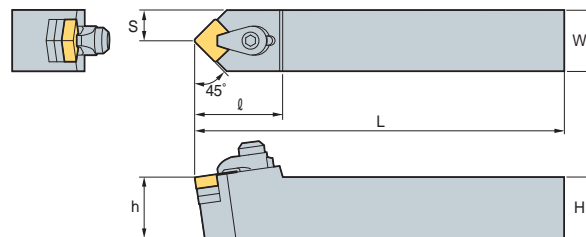

45°

(mm)

Designation	H	W	L	S	h	ℓ	Insert	Clamp	Screw	Shim	Spring	Wrench
CSDNN 2525-M12C	25	25	125	12.5	25	35	SN□N 1204□□ 1207□□	CH6R3	MHX0630 SHX0310	SS42CC	SR3	HW40L HW20L

B Ceramic Holder

CSKNR/L



SN□N

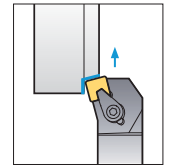
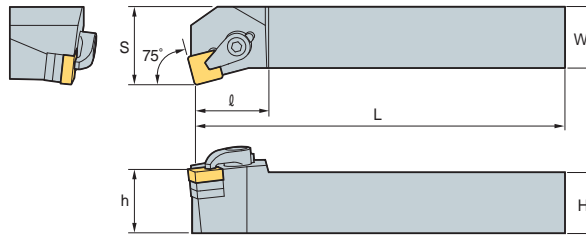

75°

• R type insert (mm)

Designation	H	W	L	S	h	l	Insert	Clamp	Screw	Shim	Spring	Wrench
CSKNR/L 2525-M12C	25	25	150	32	25	28	SN□N 1204□□ 1207□□	CH6R3	MHX0630 SHX0310	SS42CC	SR3	HW40L HW20L

CTFNR/L



TN□N

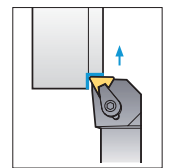
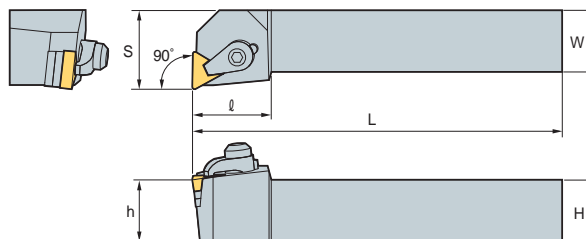

90°

• R type insert (mm)

Designation	H	W	L	S	h	l	Insert	Clamp	Screw	Shim	Spring	Wrench
CTFNR/L 2525-M16C	25	25	150	32	25	32	TN□N 1604□□ 1607□□	CH6R3	MHX0630 SHX0310	ST32CC	SR3	HW40L HW20L

CTGNR/L



TN□N

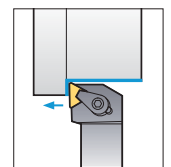
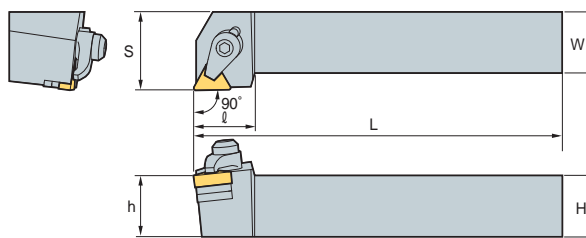

90°

• R type insert (mm)

Designation	H	W	L	S	h	l	Insert	Clamp	Screw	Shim	Spring	Wrench
CTGNR/L 2525-M16C	25	25	150	32	25	32	TN□N 1604□□ 1607□□	CH6R3	MHX0630 SHX0310	ST32CC	SR3	HW40L HW20L



Note) Generally, two shims are clamped to a Ceramic Holder.

However, only one shim is used in clamping 1207□□ and 1607□□ sized inserts.



High pressure coolant holder for inconel machining

KHP *new*

KORLOY High Pressure Coolant holder

- 300% increased productivity on Inconel machining vs. low pressure coolant system
- Cooling, tool life, and chip control are improved by the high volume coolant multi-directional injection system

Structure of Holder

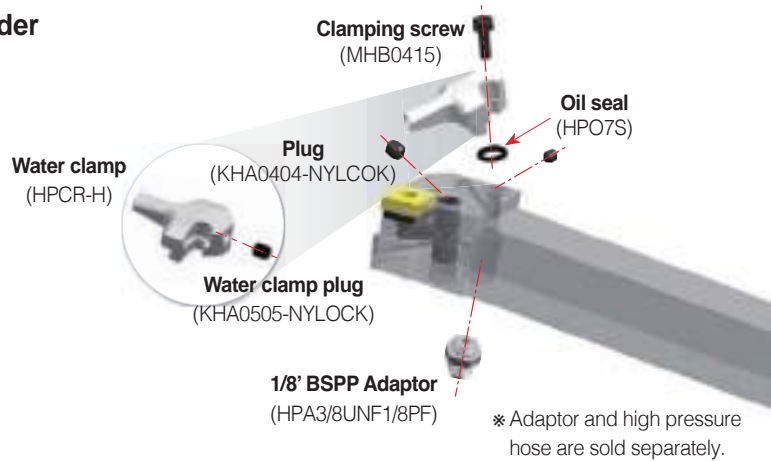

Features

- The optimal distance between the insert and the jet orifice and the ideal place of the jet orifice
- Maximized pressure of coolant due to the streamlined jet orifice
- Easy to clamp an insert for sliding clamp system

MAX 300 bar

Workpiece	The minimum pressure	The maximum pressure
P	50	300
M	70	
K	60	
N	50	
S	70	



The original position of water clamp

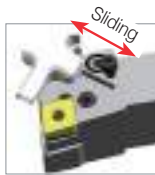

The position of placing insert



Optimal position and distance of spraying



Oval direct spray

Water clamp with a hole

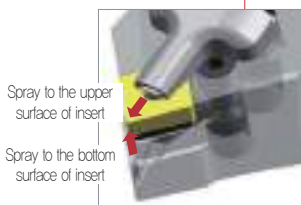

Water clamp with three holes

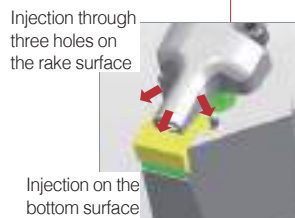
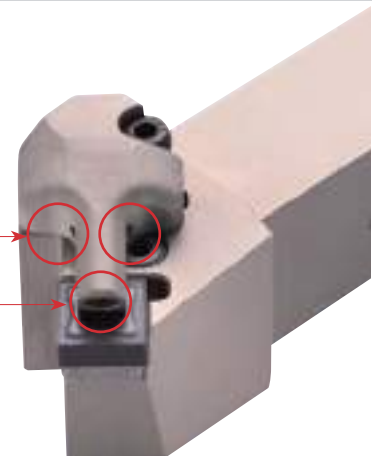

B Technical Information for KHP

How to use the water clamp



Application range

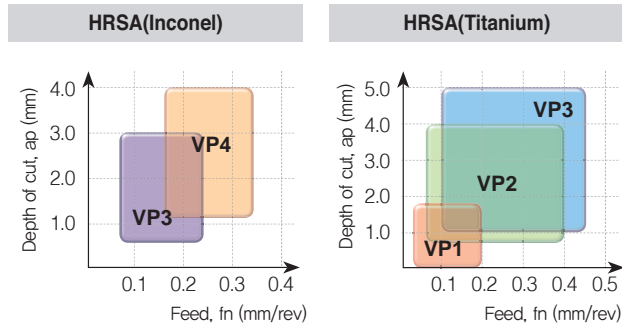

Grade Line-up

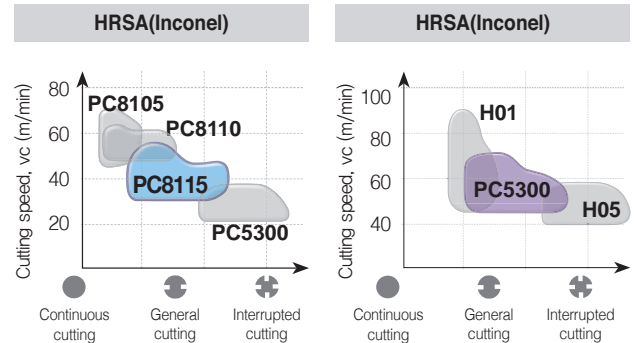

How to clamp the KHP

- Easy to clamp with 3 types of installation system
- The banjo type hose provides wider area for machining



- ※ Blank including a fixed oil seal provides easy clamping
- ※ Banjo screws provide easy clamping and clamping a holder to the turning machine with various types of blanks.

Components of KHP

- The components of high pressure coolant are sold separately
- Various components are available according to different machining sites and uses machining with high pressure coolant

Designation	Shape	Hose length	High pressure hose	Blank	Adaptor	Banjo screw	Copper washer	Pic.
HPH3/8UNF-200-SET	S S	200mm	1 EA	1 EA	2 EA	-	-	1
HPH3/8UNF-250-SET		250mm						
HPH3/8UNF1/8PF-200-SET	S B	200mm	1 EA	1 EA	1 EA	1 EA	3EA	2
HPH3/8UNF1/8PF-250-SET		250mm						
HPH1/8PF-200-SET	B B	200mm	-	-	-	2 EA	5EA	3
HPH1/8PF-250-SET		250mm						



PCLNR/L



CN□□

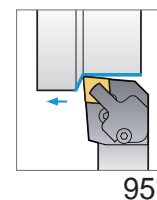
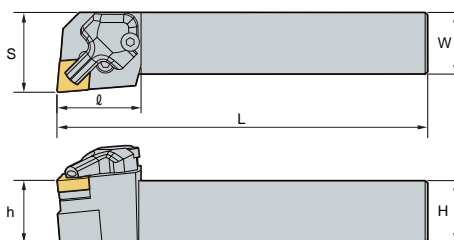
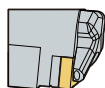

95°

• R type insert
(mm)

Designation	H	W	L	S	h	l	Insert	Lever	Screw	Shim	Ship pin	Wrench	Shim Pin Punch	Clamp	Clamping screw	Oil seal	Plug
PCLNR/L 2525-M12-KHP	25	25	150	32	25	34	CN□□1204□□										
3232-P12-KHP	32	32	170	40	32	34											

➔ Applicable inserts B28-B35

PDJNR/L



DN□□

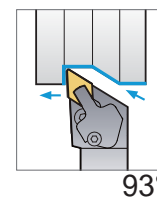
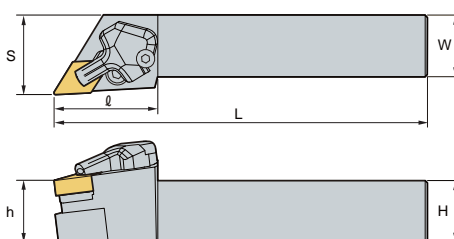
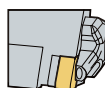

93°

• R type insert
(mm)

Designation	H	W	L	S	h	l	Insert	Lever	Screw	Shim	Ship pin	Wrench	Shim Pin Punch	Clamp	Clamping screw	Oil seal	Plug										
PDJNR/L 2525-M11-KHP	25	25	150	32.25	25	42	DN□□1104□□																				
2525-M1504-KHP	25	25	150	32.25	25	42	DN□□1504□□											LV3AN	VHX0617N	SD32N	SP3	HW20L HW25L HW30L	LSPS3	HPCR-H	MHB0415	HPO7S	KHA0404- NYLOCK
2525-M1506-KHP	25	25	150	32.25	25	42	DN□□1506□□											LV4BN	VHX0821N	SD43N	SP4N	HW20L HW30L	LSPS4	HPCR-H	MHB0415	HPO7S	KHA0404- NYLOCK

➔ Applicable inserts B36-B42

PSSNR/L



SN□□

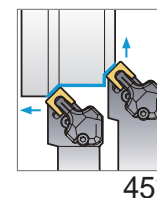
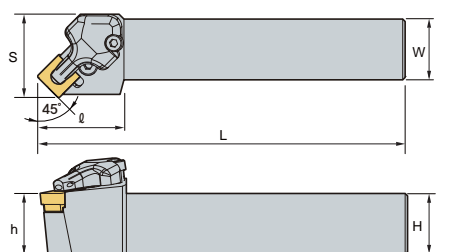
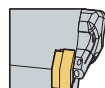

45°

• R type insert
(mm)

Designation	H	W	L	S	h	l	Insert	Lever	Screw	Shim	Ship pin	Wrench	Shim Pin Punch	Clamp	Screw bolt	Oil seal	Screw plug
PSSNR/L 2525-M12-KHP	25	25	150	34.25	25	34	SN□□1204□□										
							LV4N										

➔ Applicable inserts B44-B52

PWLNR/L



WN□□

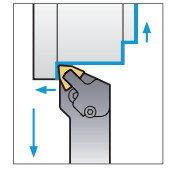
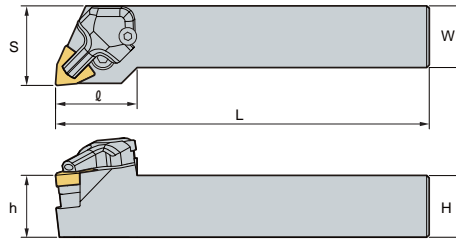
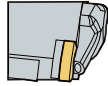

95°

• R type insert
(mm)

Designation	H	W	L	S	h	l	Insert	Lever	Screw	Shim	Shim pin	Wrench	Shim Pin Punch	Clamp	Clamping screw	Oil seal	Plug
PWLNR/L 2525-M08-KHP	25	25	150	32.25	25	33	WN□□0804□□										
3232-P08-KHP	32	32	170	39.25	32	33											

➔ Applicable inserts B62-B65

SRGCR/L



RCGT

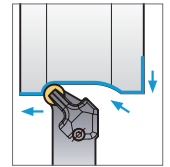
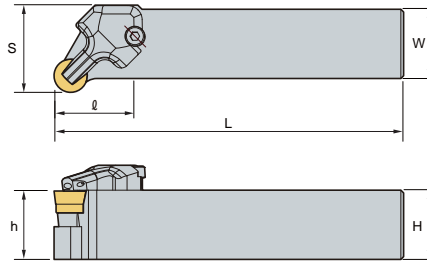

• R type insert
(mm)

Designation	H	W	L	S	h	l	Insert	Screw	Shim	Shim Screw	Wrench	Clamp	Clamping screw	Oil seal
SRGCR/L 2525-M12-KHP	25	25	150	31.5	25	-	RCGT1204M0							
								FTGA03512	SR12S	SHXN0509F	HW15P HW30L HW35L	HPCR/L-3H	MHB0415	HPO7S

➔ Applicable inserts B93

SVJBR/L



VB□□

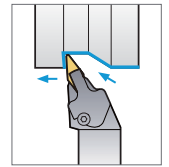
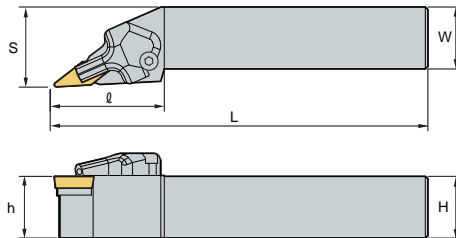

93°

• R type insert
(mm)

Designation	H	W	L	S	h	l	Insert	Screw	Shim Screw	Shim	Wrench	Clamp	Clamping screw	Oil seal
SVJBR/L 2525-M16-KHP	25	25	150	32.5	25	46.5	VB□□1604□□							
								FTGA03512	SHXN0509F	SV32S	TW15P HW30L HW35L	HPCR-H	MHB0415	HPO7S

➔ Applicable inserts B84-B85, B96

