

PALSA(Multi Edge)

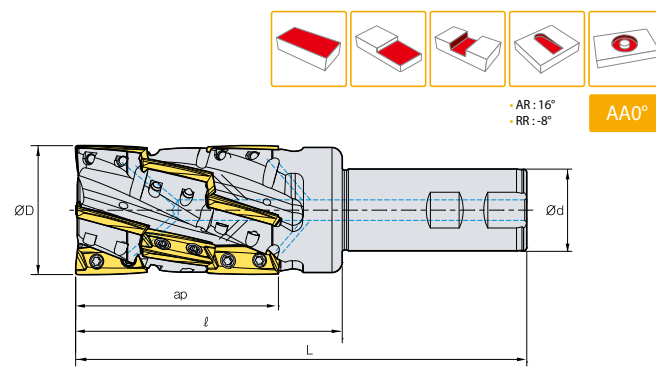

Designation	⊙	ØD	Ød	ℓ	L	ap	lbs
PALSA 250HM-4S125	12	2.5	1.25	5.118	8.661	3.78	4.97
250HM-4S150	12	2.5	1.50	5.118	8.661	3.78	5.51

Parts

Screw	Wrench	Applicable cutter Dia.
FTGA0511-P	TW20-100	Ø2.50

Available Inserts

Type	Designation	Coated								Cermet			Uncoated			
		NCM325	NCM335	NC5330	PC3500	PC3545	PC9530	PC215K	PD2000	CN2000	CN20	CN50	H01	G10	ST30A	ST20
Ø2.50	LXET 340SPEFR-250-MA															
	340SPEER-250-ML															

●: Stock item

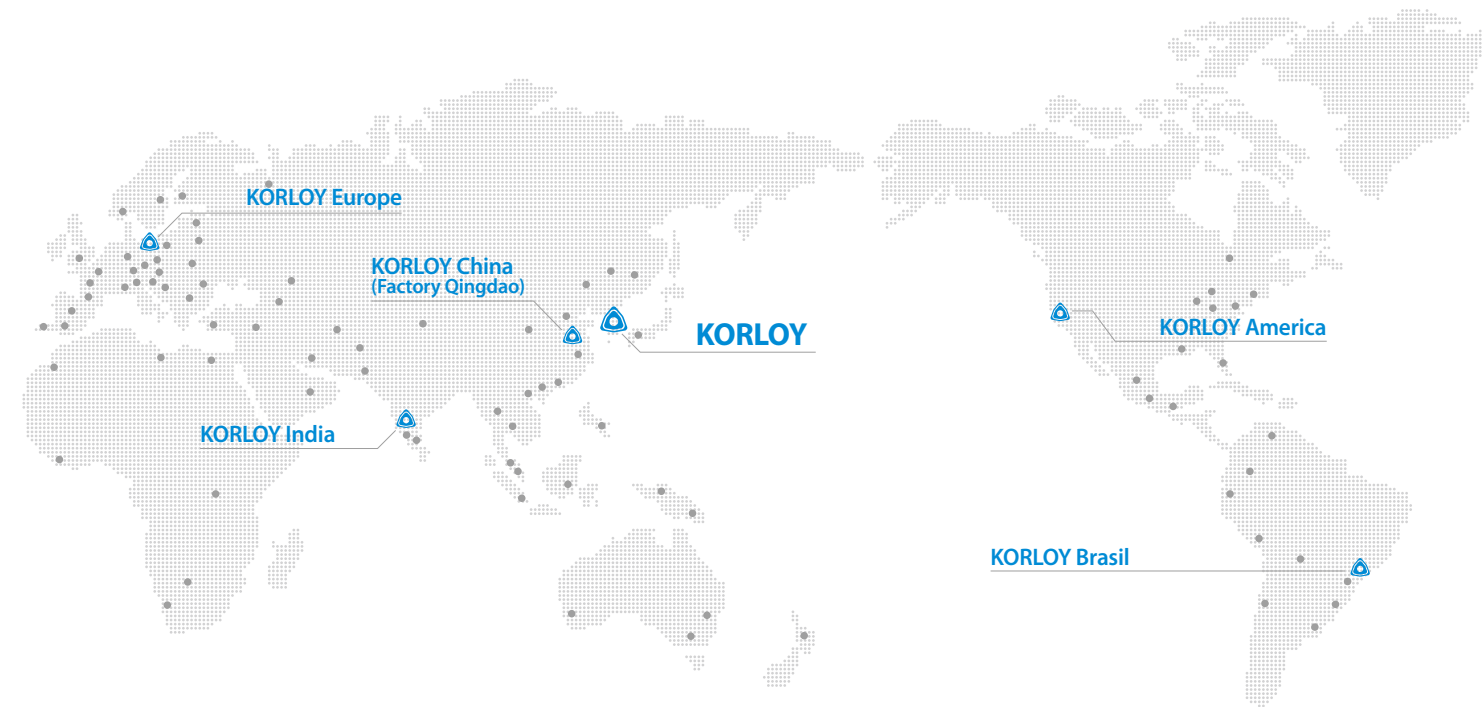

KORLOY

Head Office

Holytar B/D, 1350, Nambusunhwan-ro, Geumcheon-gu, Seoul, 153-823, Korea
 Tel : +82-2-522-3181 Fax : +82-2-522-3184, +82-2-3474-4744
 Web : www.korloy.com E-mail : export@korloy.com

Cheongju Factory

55, Sandan-ro, Heungdeok-gu, Cheongju-si, Chungcheongbuk-do, 361-290, Korea
 Tel : +82-43-262-0141 Fax : +82-43-262-0146

Jincheon Factory

54, Gwanghyewonsandan 2-gil, Gwanghyewon-myeon, Jincheon-gun, Chungcheongbuk-do, 365-831, Korea
 Tel : +82-43-535-0141 Fax : +82-43-535-0144

R & D Institute

55, Sandan-ro, Heungdeok-gu, Cheongju-si, Chungcheongbuk-do, 361-290, Korea
 Tel : +82-43-262-0141 Fax : +82-43-262-0711

KORLOY AMERICA Inc.

620 Maple Avenue, Torrance, CA 90503, USA
 Tel : +1-310-782-3800 Toll Free : +1-888-711-0001 Fax : +1-310-782-3885 E-mail : sales@korloy.us
www.korloyamerica.com



Seoul Headquarter



KORLOY Engineering Center



Cheongju Research & Development



Jincheon Factory Office



Jincheon Factory

20140520
 TN08-EI-01



Quality, Performance, Value - Guaranteed!

New indexable milling tool for the machining of high quality workpieces

Pro-L Mill



The completion of Indexable Milling Tool for high qualified workpiece

- Improved perpendicularity and lower cutting resistance by composition of clearance face and High Helix edge
- Improved chip flow due to helical type design of chip pocket and application of coolant system



KORLOY

