

Standard Programme – Performance Clamping  
**HPH CHUCKS**



# CLAMPING TECHNOLOGY



## The optimal clamping tool for every application

On using tools, their connection to the machine spindle, and therefore the clamping technology, plays a central role that is often undervalued.

On fine machining parts, very good results can be achieved with the highest radial run-out accuracies. The effect is very significant even on drilling or milling, as lower radial variations have a positive effect on tool lives.

Manufactured with the latest technology, the clamping technology programme from WTE offers the perfect solution for every application and a connection that ensures the tool has the necessary performance, radial run-out and change-

over accuracy in use. From the CNC precision drill chuck, through clamping tools with flange module, hydraulic and shrinking technology to adapters, the WTE standard programme covers a wide variety of systems and technologies. WTE offers a comprehensive standard programme also for machining with minimum quantity lubrication MQL.



Drilling from the solid |  
Boring | Countersinking



Milling



Turning



Reaming | Fine boring

# PRODUCT OVERVIEW CLAMPING TECHNOLOGY

## Hydraulic Chucks



### Features

- High run-out accuracy
- Vibration damping effect
- High radial stiffness
- Clamping without additional devices
- Quick setup times
- Flexible clamping range using reducing sleeves
- With resealable coolant duct holes
- With adjusting technology

### Available shank forms

- SK
- HSK-A
- HSK-C
- HSK-E
- HSK-F
- BT
- Module
- Adapter

### Maximum speed

Up to 40000 min<sup>-1</sup>

### Spare parts & accessories

- Reducing Sleeves
- Shrink Extensions
- Hydraulic Expansion Extensions
- Stop Screws
- Pressure Screws
- Coolant Transfer Pipe
- Misc. keys for adjustments

## HPH - High Performance Holder



### Features

- Very high holding forces
- Vibration damping effect
- High thermal stability
- All commercially available shanks can be clamped
- Quick setup times
- Very high transmissible torques
- Narrow design 3°
- With resealable coolant duct holes

### Available shank forms

- SK
- HSK-A
- HSK-C
- HSK-E
- HSK-F
- BT

### Maximum speed

Up to 40000 min<sup>-1</sup>

### Spare parts & accessories

- Reducing Sleeves
- Shrink Extensions
- Hydraulic Expansion Extensions
- Stop Screws
- Pressure Screws
- Coolant Transfer Pipe
- Misc. keys for adjustments

## Shrink Chucks



### Features

- High run-out accuracies
- Vibration damping effect
- High transmissible torques
- High flexibility in contours
- Creep resistant workable steel
- Side coolant duct hole
- With resealable coolant duct holes
- Narrow design 3°

### Available shank forms

- SK
- HSK-A
- HSK-C
- HSK-E
- HSK-F
- BT
- Module
- Adapter

### Maximum speed

Up to 40000 min<sup>-1</sup>

### Spare parts & accessories

- Shrink Extensions
- Coolant Transfer Pipe
- Misc. keys for adjustments

## CNC Precision Drill Chucks

**Features**

- Various clamping ranges possible
- Reliable pinion-bevel gear drive
- Clockwise and counter-clockwise rotation possible
- Slim construction

**Available shank forms**

- SK
- HSK-A, HSK-C, HSK-E, HSK-F
- B12
- BT
- Wohlhaupter
- 1835B
- VDI
- MORI-SEIKI
- ABS
- KOMET
- MK
- MAZAK
- UTS Widia
- PSC
- DECKEL
- CHIRON

**Maximum speed**

Up to 35000 min<sup>-1</sup>

**Spare parts & accessories**

Chuck assembly available as individual part;  
Coolant Transfer Pipe; Misc. keys for adjustments

## NC Standard Drill Chucks

**Features**

- 2 different clamping ranges possible
- Reliable pinion-bevel gear drive
- Clockwise and counter-clockwise rotation possible
- Slim construction

**Available shank forms**

- SK
- BT

**Maximum speed**

Up to 7000 min<sup>-1</sup>

**Spare parts & accessories**

Chuck assembly available as individual part;  
Coolant Transfer Pipe; Misc. keys for adjustments

## MICRO Universal Chucks

**Features**

- Continuously expandable clamping range
- for tool shanks from 0.2 to 6.4 mm
- High holding forces
- Quick setup times
- Flexible clamping

**Available shank forms**

- SK
- HSK-A
- HSK-E
- BT
- Cylindrical shank

**Maximum speed**

Up to 60000 min<sup>-1</sup>

**Spare parts**

Spare parts are only available on request.  
Please contact our Customer Service Team  
or your authorised WTE dealer.

# PRODUCT RANGE



## 1 Shrink Chucks

In long, short and heavy-duty design, however also with 3 degrees or KKB

## 2 HPH - High Performance Holder

In long, ultra-short and short heavy-duty design, however also with 3 degrees in additive design

## 3 Hydraulic Chuck

In long, ultra-short and short heavy-duty design as well as with compensation technology

## 4 NC Standard Drill Chucks

## 5 CNC Precision Drill Chucks

In all common shank forms

## 6 MICRO Universal Chucks

Also with cylindrical shank extension



## INNOVATIONS | HIGHLIGHTS

### HPH 3° Multi High Performance Holder with narrow contour 3 degrees



WTE has achieved a revolution in clamping technology with the HPH 3° Multi with narrow contour. Thanks to additive manufacturing, it has become possible to utilise the benefits of a hydraulic chuck in an even wider field of applications for the first time. On the one hand, the new chuck exhibits the narrow contour with the 3° back taper known from the shrink chuck and the familiar high holding forces, but does without costly shrink units.

The wide operating temperature range up to 120 °C ensures additional process reliability. It is suitable for all machining operations, particularly in contour-critical areas from a clamping diameter of 3 mm.

#### AT A GLANCE

- Reliable clamping even at temperatures up to 120 °C
- Optimum radial run-out accuracy of 3 µm with a projection length of 2.5 x D
- Better surface finish with longer tool life of the tool
- Shorter set-up times and lower tool costs

### HPH - High Performance Holder short heavy-duty design with resealable cooling channel bores



The WTE HPH in the short heavy-duty design has excellent rigidity, high torque transmission and withstands high thermal loads up to 120 °C, as occur for example during HPC milling. The bending resistance is 1.4 times greater than a conventional shrink chuck. In addition, WTE offers the HPH as a short heavy-duty design with resealable cooling channel bores. In this way the range of applications is expanded. It is also possible to use tools without internal cooling. In

use these advantages guarantee a very high-quality surface finish on the part, significantly higher milling speeds and shorter machining times. In addition, due to the good damping properties, chipping on the tool's cutting edge is prevented and as a result longer tool lives achieved for the tool used.

#### AT A GLANCE

- Maximum torque transmission
- Compact design
- Thermal stability up to 120 °C
- Resealable cooling channel bores
- Ideal for heavy machining
- Optimal damping properties for long tool life



## Hydraulic chuck Comp-R



The hydraulic chuck Comp-R guarantees perfect radial run-out on the usage of multi-bladed reamers in a close tolerance range. The error on the total system due to the tolerances on the spindle, clamping tool and tool is compensated and perfect radial run-out guaranteed. The Comp-R is perfectly suited to light machining tasks with multi-bladed reamers. In addition to the proven WTE hydraulic clamping technology,

it is possible to set, at three adjusting elements, the radial run-out exactly in a setting range of up to 10  $\mu\text{m}$ . The radial run-out is corrected straightforwardly and quickly using a hex wrench depending on the direction of the error. The system is self-locking, unintentional movement during fine machining is impossible.

### AT A GLANCE

- Compensation of errors on the overall system
- Easy handling
- No jamming of the tool
- Better surface quality and tool life
- Dirt resistant and low maintenance

## Hydraulic chuck with module connection



WTE hydraulic chucks with flange module are optimal for machining operations that require the compensation of radial run-out and angular errors on the machine spindle. These are adjusted radially using adjusting elements and produce

accuracies in the  $\mu$  range. In combination with the advantages of hydraulic technology, such as vibration damping, increased of tool lives.

### AT A GLANCE

- Compensation of radial run-out and angular errors
- Easy handling
- Better surface quality and longer tool life

# CHUCK SYSTEMS



## Hydraulic clamping technology

### Hydraulic chucks

Due to their high radial run-out accuracy and the resulting even cutting action as well as the excellent vibration damping, WTE hydraulic chucks guarantee optimal workpiece finishes. In addition, microstructure cracking on the tool's cutting edge is prevented by the hydraulic system, the tool lives increased and costs reduced. The high clamping reliability is ensured even at high spindle speeds. The chucks can be adjusted to the  $\mu$  thanks to axial and radial length adjustment. Designs for minimum quantity lubrication as well as short heavy-duty and ultra-short designs with steep taper are available in the standard programme.

#### ADVANTAGES

- Radial or axial length adjustment to the  $\mu$
- No reduction in the clamping forces at high spindle speeds, as a result high process reliability.
- Increased tool life due to very high radial run-out accuracy and repetition accuracy
- Suitable for MQL



### HPH - High Performance Holders

The new High Performance Holders combine the damping properties of hydraulic clamping technology with the high holding forces of shrinking technology. Thanks to an innovative manufacturing process, the chucks impress due to high torque transmission, ideal damping properties, outstanding rigidity of the overall system and a radial run-out accuracy of  $< 3 \mu\text{m}$ . The bending resistance is 1.4 times greater than a conventional shrink chuck in accordance with DIN 69882-8. In use these advantages guarantee a high surface finish on the part, significantly higher machining speeds and therefore short machining times, preventing chipping on the tool's cutting edge and permit long tool lives. The standard programme of HPHs covers short versions with additional decentral resealable cooling channel bores, an additively manufactured slender 3-degree design with direct clamping from a diameter of 3 mm, as well as versions for minimum quantity lubrication MQL.

#### ADVANTAGES

- High torque transmission
- Process reliability up to 120 °C
- Suitable for MQL





## Shrinking technology

### Shrink chucks

Using the shrink chucks the tools can be accurately clamped for almost all milling operations. High torque transmission and radial rigidity characterise this chuck. Long-term radial run-out accuracy and repetition accuracy of <math>< 3 \mu\text{m}</math> in the location bore guarantee high dimensional accuracy of the workpiece. The shrink chucks from WTE are finely balanced as standard so that high surface finishes and long tool lives are ensured. The standard programme of shrink chucks includes designs with slender external contour, heavy-duty designs as well as a broad MQL program. In addition, long designs up to 300 mm with HSK-A shank are available.

#### ADVANTAGES

- High torque transmission and radial rigidity.
- Long service life due to usage of heat-resistant tool steel
- Numerous possible combinations of shrink chucks and extensions.
- Suitable for MQL

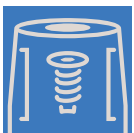

## Mechanical tool clamping

### CNC precision drill chucks | NC standard drill chucks | MICRO universal chucks

Mechanical chucks impress due to their simple construction and the uncomplicated handling. The clamping is safeguarded regardless of the direction of rotation even at high spindle speeds. The standard programme for mechanical tool clamping covers precision drill chucks that are also available in a micro design with direct clamping from 0.2 mm. Due to the modular design, the drill chucks are available with all forms of machine-side connections.





#### ADVANTAGES

- Simple construction and uncomplicated handling
- Safe clamping regardless of direction of rotation
- High spindle speed strength
- Modular design makes it possible to use drill chuck heads on all tool connections

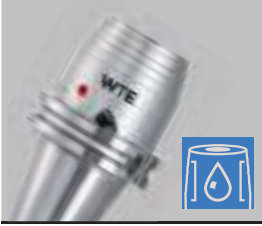

# SELECTION OF A CHUCK

The optimal chuck for every application

Chuck	Design	Milling			Drilling	Reaming
		HPC	Roughing	Finishing		
	Standard	<input type="checkbox"/>	<input type="checkbox"/>	<input checked="" type="checkbox"/>	★	★
	Short heavy-duty design <sup>1)</sup>	<input type="checkbox"/>	<input type="checkbox"/>	<input checked="" type="checkbox"/>	★	★
	Radial length adjustment	<input type="checkbox"/>	<input type="checkbox"/>	<input checked="" type="checkbox"/>	★	★
	Adjustable <sup>3)</sup>	<input type="checkbox"/>	<input type="checkbox"/>	<input checked="" type="checkbox"/>	<input checked="" type="checkbox"/>	★
	With dec. cooling channel bores <sup>2)</sup>	<input type="checkbox"/>	<input type="checkbox"/>	<input checked="" type="checkbox"/>	★	★
	Standard	<input checked="" type="checkbox"/>	<input checked="" type="checkbox"/>	<input checked="" type="checkbox"/>	<input checked="" type="checkbox"/>	<input checked="" type="checkbox"/>
	Short heavy-duty design <sup>1)</sup>	★	★	★	<input checked="" type="checkbox"/>	<input checked="" type="checkbox"/>
	Short heavy-duty design with cooling channel bores <sup>1)2)</sup>	★	★	★	<input checked="" type="checkbox"/>	<input checked="" type="checkbox"/>
	Narrow contour <sup>3°</sup>	<input type="checkbox"/>	<input type="checkbox"/>	★	★	★
	Standard	<input checked="" type="checkbox"/>	<input checked="" type="checkbox"/>	<input checked="" type="checkbox"/>	<input checked="" type="checkbox"/>	<input checked="" type="checkbox"/>
	Short design <sup>4)</sup>	<input checked="" type="checkbox"/>	<input checked="" type="checkbox"/>	<input checked="" type="checkbox"/>	<input checked="" type="checkbox"/>	<input checked="" type="checkbox"/>
	With dec. cooling channel bores <sup>2)</sup>	<input checked="" type="checkbox"/>	<input checked="" type="checkbox"/>	<input checked="" type="checkbox"/>	<input checked="" type="checkbox"/>	<input checked="" type="checkbox"/>
	Narrow contour <sup>3°</sup>	<input type="checkbox"/>	<input type="checkbox"/>	<input checked="" type="checkbox"/>	<input checked="" type="checkbox"/>	<input checked="" type="checkbox"/>
	CNC Precision Drill Chucks	<input type="checkbox"/>	<input type="checkbox"/>	<input type="checkbox"/>	★	<input checked="" type="checkbox"/>
	NC Standard Drill Chucks	<input type="checkbox"/>	<input type="checkbox"/>	<input type="checkbox"/>	★	<input type="checkbox"/>
	MICRO Universal Chucks	<input type="checkbox"/>	<input type="checkbox"/>	<input checked="" type="checkbox"/>	★	<input checked="" type="checkbox"/>

★ = 1st choice |  = highly suitable |  = suitable in some situations |  = not suitable

<sup>1)</sup> Short/heavy-duty design: Compact design for high rigidity.

<sup>2)</sup> With cooling channel bores: Chuck with additional decentral coolant outlets that, optionally, are resealable.

<sup>3)</sup> With compensation technology: Alignment function on the chuck for radial alignment feature for the compensation of radial run-out errors on the overall system.

<sup>4)</sup> Heavy-duty design: Reinforced contour for heavy-duty machining tasks, optionally with additional cooling channel bores.

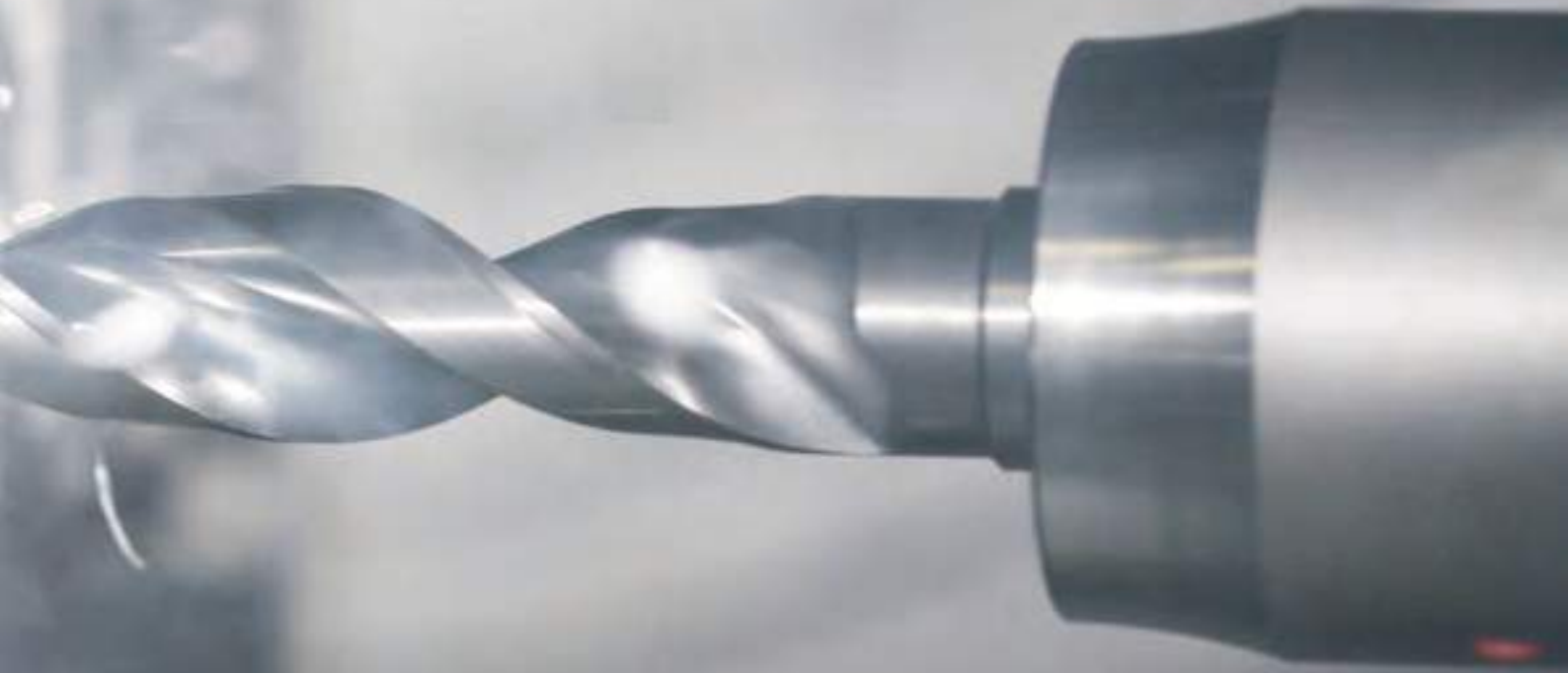

# Hydraulic clamping technology

## Application of WTE hydraulic clamping technologies



Our Hydraulic Chucks or HPH - High Performance Holder with axial and radial activated length adjustment can be used on wood and metal processing machines with rotating tools. There are different designs depending on the type of use, for example

Chucks for automatic tool change as per:  
ISO 7388-1 (DIN 69871); DIN 69893-HSK A, DIN 69893-F, DIN  
ISO 7388-2 (JIS B6339)

Chucks for manual tool change as per:  
DIN 69893-C

## Advantages of the WTE hydraulic clamping technology

- Extremely fast tool change
- High run-out accuracy
- Vibration damping tool clamping
- Increase of tool service life
- Reduction of micro-breakouts on the tool cutting edge
- Improvement of surface quality
- Can be used flexibly by using reducing sleeves
- Low maintenance costs due to closed clamping system
- Simple operation
- High torque transfer
- Design conforms to DIN 69882-7
- High positioning accuracy and repeatability
- Tool clamping with maximum run-out accuracy (maximum 3 µm)
- Continuous development
- Certified products as per DIN EN ISO 9001:2008 manufactured in Germany

## Elements of the hydraulic clamping technology

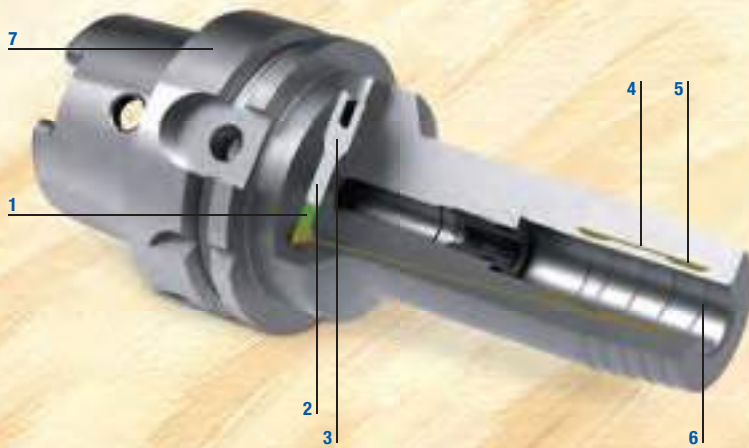

- 1 Sealing element** Seepage losses in the clamping bore are prevented by the lip seal.
- 2 Piston** Presses the hydraulic medium into the chamber system.
- 3 Clamping screw** A torque wrench is not necessary to actuate the piston for clamping.
- 4 Expanding sleeve** Clamps the tool shank centrally with evenly applied pressure.
- 5 Chamber system** Is produced by the connection of the expanding sleeve and body. Due to the hydraulic medium has a damping action on the tool and therefore a wear-reducing effect.
- 6 Groove** Oil, grease or lubricant residue is displaced into the groove by the high clamping pressure. The clamping surfaces remain largely dry, the transmission of the torque is ensured.
- 7 Body material** WTE hydraulic chucks are available for all common machine-side connections (HSK-A, HSK-C, SK, BT and flange module).

## Functional principle

On clamping using hydraulic clamping technology, an even pressure is built up in a sealed chamber system using a clamping screw and a piston. This pressure is applied to the tool via the built-in expanding sleeve.

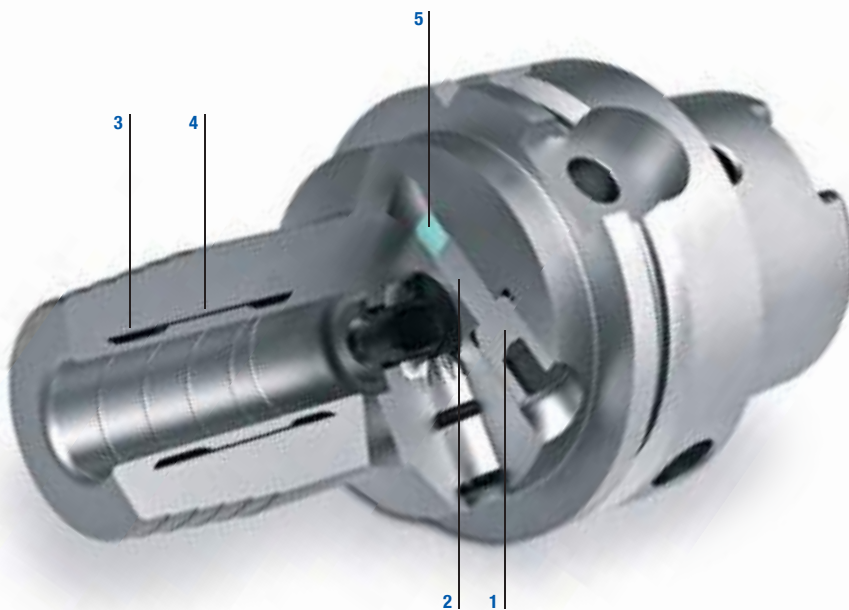

- 1** The clamping screw is screwed in to the stop using a hex wrench.
- 2** The piston presses the hydraulic medium into the
- 3** expansion chamber and causes the pressure to increase.
- 4** The thin-walled expanding sleeve bows evenly against the tool shank. Due this clamping process the tool shank is first centred and then powerfully clamped over a large area.
- 5** The sealing element ensures absolute freedom from leaks and a long service life.

## HPH 3° Multi - additively manufactured hydraulic clamping technology

WTE achieves a revolution in clamping technology with the new HPH technology with slender contour. For the first time it has become possible to utilise the benefits of a hydraulic chuck in an even wider field of applications. On the one hand, the new chuck has a slender contour with the 3° back taper known from the shrink chuck. On the other hand it offers the advantages of the WTE HPH (High Performance Holder). The new chuck offers significant benefits not only for mould making, but also for applications in the automotive and aerospace sector. Why? The HPH technology with slender contour is also suitable for all machining tasks in contour-critical areas.



## Hydraulic clamping technology with compensation technology

The "Comp-R" chuck is perfectly suited to light machining tasks with multi-bladed reamers. It builds on hydraulic clamping technology and the radial run-out can be set exactly using three adjustment elements. The radial run-out is corrected straightforwardly and quickly using a hex wrench depending on the direction of the error. The setting range is up to 10 µm. Wedges in the chuck align the tool, jamming of the tool is prevented. The system is self-locking, unintentional movement during fine machining is impossible. A fixed ring seals the alignment system. It is therefore low maintenance and not susceptible to dirt.

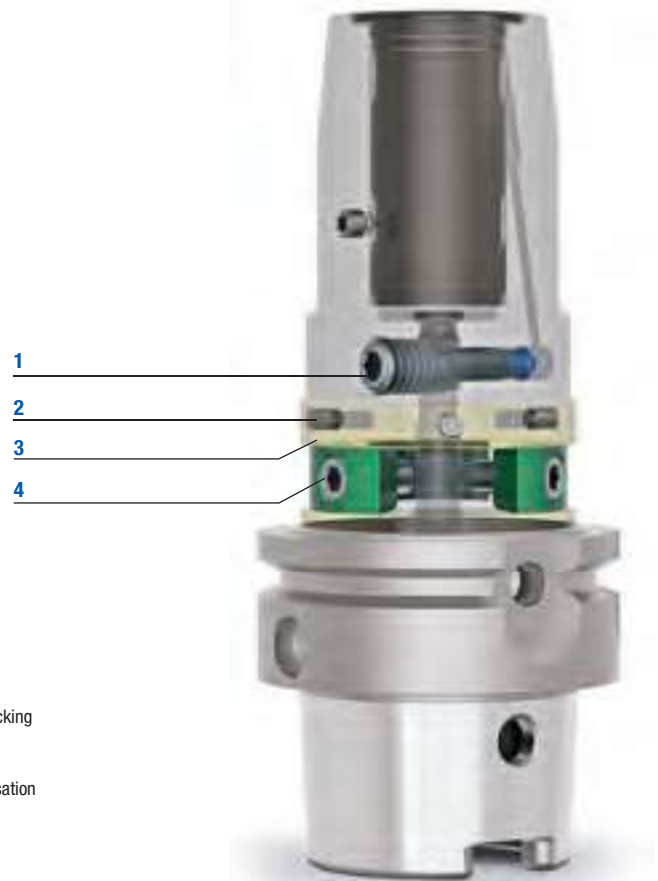



## Setting and handling notes for the run-out alignment of the Comp-R



### NOTE

The locking ring (3) is secured by a screw with locking varnish (2) and is not allowed to be removed.

1. Tighten the three adjusting screws (4) to a tightening torque of 1 Nm.
2. Measure the Comp-R using a run-out measuring device.
3. Tighten the adjusting screws (4) (to maximum 3 Nm) until the Comp-R has the stipulated radial run-out.
4. After the radial run-out alignment, set the required balancing value.

#### Result:

The radial run-out alignment of the Comp-R is complete.



- 1 Clamping screw
- 2 Screw for locking ring with locking varnish (3 pieces)
- 3 Locking ring
- 4 Adjusting screws for compensation adjustment (3 pieces)



## Safe clamping / care and maintenance

All hydraulic chucks and HPH - High Performance Holders - should, on correct operation in accordance with the operating manual, be checked for correct function and safety during each clamping process.

If deviations are found, the permitted transmittable torques may not be reached.

As a consequence it is recommended to have the hydraulic chuck checked by our repair service.

Prior to the usage of our hydraulic clamping technologies, the related location bores and taper surfaces are always to be cleaned. The clamping screw for the chuck must be regularly cleaned and lubricated to suit the conditions of usage and the ambient conditions.

The clamping device should only be stored in the unclamped state; attention is to be paid to corrosion protection.

# HPH - HIGH PERFORMANCE HOLDER



## Shank form SK as per DIN69871

---

SK 40 \_\_\_\_\_ 20-23

SK 50 \_\_\_\_\_ 24

## Shank form HSK

---

HSK-A 63 \_\_\_\_\_ 25-28

HSK-A 100 \_\_\_\_\_ 29-30

## Shank form BT

---

BT 40 \_\_\_\_\_ 31-37

## Spare parts & accessories

---

Spare parts & accessories \_\_\_\_\_ 38-40



# HPH - High Performance Holder

## HPH 3° MULTI, DIN69871, Form AD/AF

(prev. DIN 69871-AD/B), narrow design, 3°

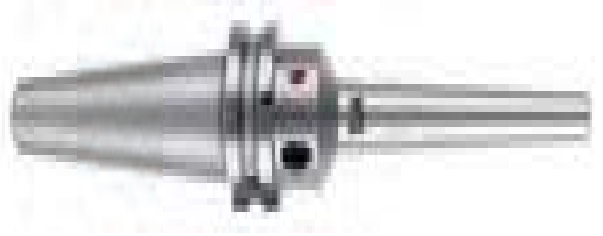
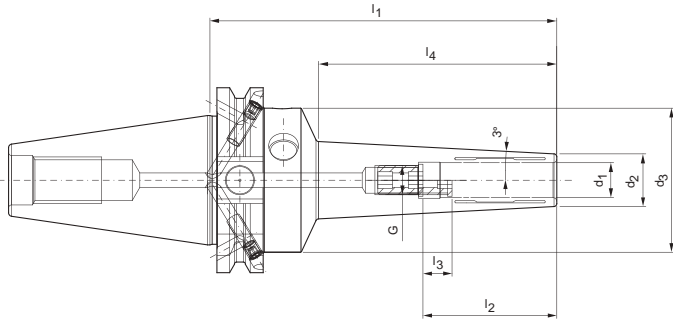

Nominal size SK/ISO	Dimensions							G	sw	Weight [kg]	Order designation	Order No.
	d <sub>1</sub>	d <sub>2</sub>	d <sub>3</sub>	l <sub>1</sub>	l <sub>2</sub>	l <sub>3</sub>	l <sub>4</sub>					
40	6	12	49.5	120	37	10	79.9	M5	2.5	1.2	15.404.40.06.Z/120	30655468
40	8	14	49.5	120	37	10	79.9	M6	3	1.2	15.404.40.08.Z/120	30655469
40	10	16	49.5	120	41	10	80.9	M8x1	3	1.2	15.404.40.10.Z/120	30655470
40	12	18	49.5	120	46	10	81.9	M10x1	5	1.2	15.404.40.12.Z/120	30655471

Dimensions in mm.

Basic form AD. Please indicate form AF (prev. B) in your order.

Spare parts and accessories at the end of this chapter.



# HPH - High Performance Holder DIN69871, Form AD/AF

(prev. DIN 69871-AD/B), short narrow design

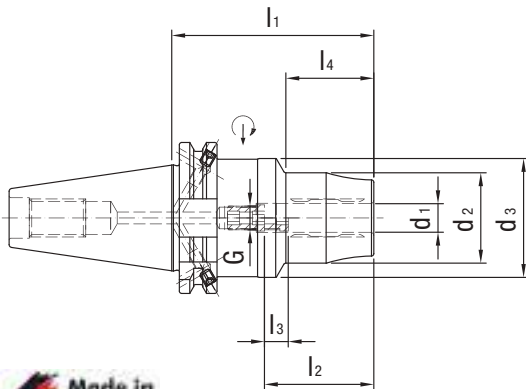

Nominal size SK/ISO	Dimensions							G	sw	Weight [kg]	Order designation	Order No.
	d <sub>1</sub>	d <sub>2</sub>	d <sub>3</sub>	l <sub>1</sub>	l <sub>2</sub>	l <sub>3</sub>	l <sub>4</sub>					
40	6	32	50	75	37	10	26	M5x15	2.5	1.4	15.407.40.06.Z	30339747
40	8	34	50	75	37	10	27	M6x15	3	1.4	15.407.40.08.Z	30339749
40	10	36	50	80	41	10	32	M8x1x15.5	3	1.4	15.407.40.10.Z	30339750
40	12	38	50	85	46	10	37	M10x1x9.8	5	1.5	15.407.40.12.Z	30339751
40	14	40	50	85	46	10	37	M10x1x13	5	1.6	15.407.40.14.Z	30339752
40	16	42	50	90	49	10	42	M12x1x15	5	1.6	15.407.40.16.Z	30339753
40	18	44	50	90	49	10	42	M12x1x17	5	1.7	15.407.40.18.Z	30339754
40	20	48	50	95	51	10	45	M16x1x15.8	5	1.7	15.407.40.20.Z	30339755
40	25	57	50	110	57	10	60	M16x1x19.8	5	2.2	15.407.40.25.Z	30339756
40	32	63	50	120	61	10	65	M16x1x25.8	5	2.5	15.407.40.32.Z	30339758

Dimensions in mm.

Basic form AD. Please indicate form AF (prev. B) in your order.

Spare parts and accessories at the end of this chapter. Custom designs available on request.



# HPH - High Performance Holder DIN69871, Form AD/AF

(prev. DIN 69871-AD/B), short heavy duty design

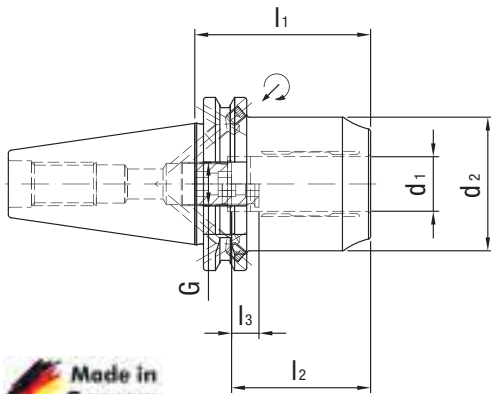

Nominal size SK/ISO	Dimensions					G	sw	Weight [kg]	Order designation	Order No.
	d <sub>1</sub>	d <sub>2</sub>	l <sub>1</sub>	l <sub>2</sub>	l <sub>3</sub>					
40	12	42	50	46	10	M8x1x13.5	3	1	15.408.40.12.Z	30494111
40	20	49	64.5	51	10	M16x1x13.5	8	1.4	15.408.40.20.Z	30372360

Dimensions in mm.

Basic form AD. Please indicate form AF (prev. B) in your order.

Spare parts and accessories at the end of this chapter. Custom designs available on request.



# HPH - High Performance Holder DIN69871, Form AD/AF

(prev. DIN 69871-AD/B), short heavy duty design, with resealable coolant duct holes

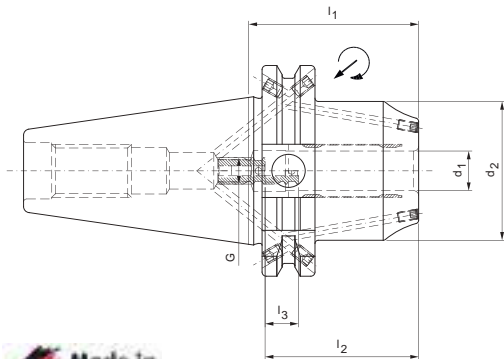

Nominal size SK/ISO	Dimensions					G	sw	Weight [kg]	Order designation	Order No.
	d <sub>1</sub>	d <sub>2</sub>	l <sub>1</sub>	l <sub>2</sub>	l <sub>3</sub>					
40	12	42	50	46	10	M8X1	3	1	15.408.40.12.KKB	30565346
40	16	46	64.5	49	10	M12x1	5	1.3	15.408.40.16.KKB	30565347
40	20	49	64.5	51	10	M16x1	8	1.4	15.408.40.20.KKB	30565348

Dimensions in mm.

Basic form AD. Please indicate form AF (prev. B) in your order.

Spare parts and accessories at the end of this chapter. Custom designs available on request.



# HPH - High Performance Holder DIN69871, Form AD/AF

(prev. DIN 69871-AD/B), short heavy duty design

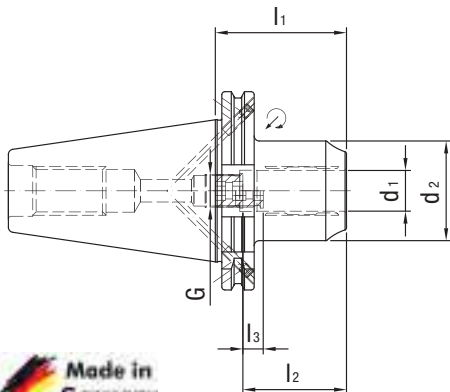

Nominal size SK/ISO	Dimensions					G	sw	Weight [kg]	Order designation	Order No.
	d <sub>1</sub>	d <sub>2</sub>	l <sub>1</sub>	l <sub>2</sub>	l <sub>3</sub>					
50	12	42	50	46	10	M8x1x13.5	3	2.8	15.408.50.12.Z	30515413
50	20	49	64.5	51	10	M16x1x13.5	8	3.1	15.408.50.20.Z	30435618
50	32	72	81	61	10	M16x1x13.5	8	4.1	15.408.50.32.Z	30471202

Dimensions in mm.

Basic form AD. Please indicate form AF (prev. B) in your order.

Spare parts and accessories at the end of this chapter. Custom designs available on request.





# HPH - High Performance Holder HPH 3° MULTI, DIN 69893-HSK A Narrow design, 3°

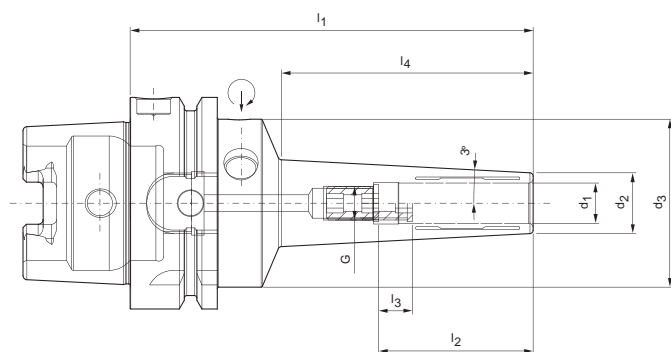

Nominal size HSK-A	Dimensions							G	sw	Weight [kg]	Order designation	Order No.
	d <sub>1</sub>	d <sub>2</sub>	d <sub>3</sub>	l <sub>1</sub>	l <sub>2</sub>	l <sub>3</sub>	l <sub>4</sub>					
63	6	12	50	120	37	10	73	M5	2.5	0.9	16.404.63.06.Z/120	30655463
63	8	14	50	120	37	10	74	M6	3	0.9	16.404.63.08.Z/120	30655465
63	10	16	50	120	41	10	74	M8x1	3	1	16.404.63.10.Z/120	30655466
63	12	18	50	120	46	10	75	M10x1	5	1	16.404.63.12.Z/120	30655467

Dimensions in mm.

Spare parts and accessories at the end of this chapter.



# HPH - High Performance Holder DIN 69893-HSK A

Short narrow design

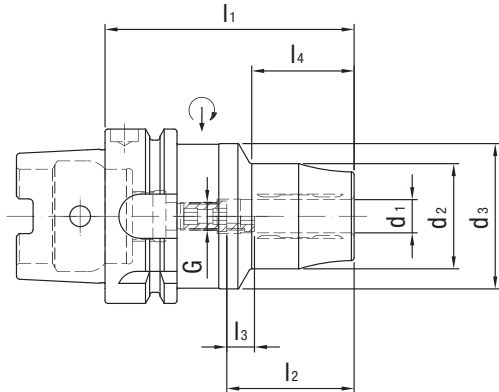

Nominal size HSK-A	Dimensions							G	sw	Weight [kg]	Order designation	Order No.
	d <sub>1</sub>	d <sub>2</sub>	d <sub>3</sub>	l <sub>1</sub>	l <sub>2</sub>	l <sub>3</sub>	l <sub>4</sub>					
63	6	32	50	80	37	10	26	M5x15	2.5	1.1	16.407.63.06.Z	30339759
63	8	34	50	80	37	10	27	M6x15	3	1.1	16.407.63.08.Z	30339760
63	10	36	50	85	41	10	32	M8x1x15.5	3	1.2	16.407.63.10.Z	30339761
63	12	38	52.5	90	46	10	37	M10x1x9.8	5	1.3	16.407.63.12.Z	30339762
63	14	40	52.5	90	46	10	37	M10x1x13	5	1.3	16.407.63.14.Z	30339763
63	16	42	52.5	95	49	10	42	M12x1x15	5	1.5	16.407.63.16.Z	30339764
63	18	44	52.5	95	49	10	42	M12x1x17	5	1.5	16.407.63.18.Z	30339765
63	20	48	52.5	100	51	10	45	M16x1x15.8	5	1.5	16.407.63.20.Z	30339766
63	25	57	53	120	57	10	62	M16x1x19.8	5	2.1	16.407.63.25.Z	30339767
63	32	63	53	125	61	10	62	M16x1x25.8	5	2.3	16.407.63.32.Z	30339768

Dimensions in mm.

Spare parts and accessories at the end of this chapter.

MQL-capable design possible on request. Custom designs available on request.



# HPH - High Performance Holder DIN 69893-HSK A

Short heavy duty design

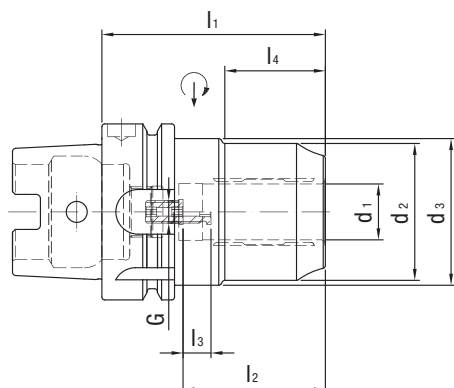

Nominal size HSK-A	Dimensions							G	sw	Weight [kg]	Order designation	Order No.
	d <sub>1</sub>	d <sub>2</sub>	d <sub>3</sub>	l <sub>1</sub>	l <sub>2</sub>	l <sub>3</sub>	l <sub>4</sub>					
63	12	42	52.5	80	46	10	34	M8x1	3	1.1	16.408.63.12.Z	30494132
63	20	49	52.5	80	51	10	36	M8x1	3	1.3	16.408.63.20.Z	30372363

Dimensions in mm.

Spare parts and accessories at the end of this chapter.

MQL-capable design possible on request. Custom designs available on request.



# HPH - High Performance Holder DIN 69893-HSK A

Short heavy duty design, with resealable coolant duct holes

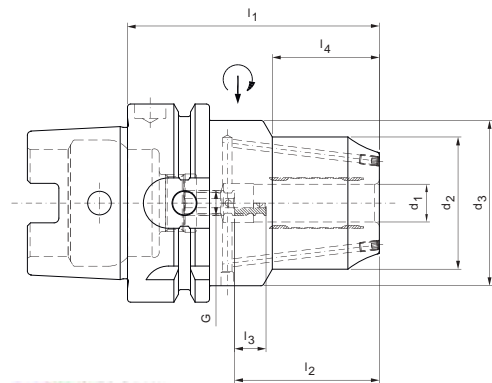

Nominal size HSK-A	Dimensions							G	sw	Weight [kg]	Order designation	Order No.
	d <sub>1</sub>	d <sub>2</sub>	d <sub>3</sub>	l <sub>1</sub>	l <sub>2</sub>	l <sub>3</sub>	l <sub>4</sub>					
63	12	42	52.5	80	46	10	34	M8x1	3	1.6	16.408.63.12.KKB	30565349
63	16	46	52.5	80	49	10	35	M8x1	3	1.4	16.408.63.16.KKB	30565353
63	20	49	52.5	80	51	10	36	M8x1	3	1.4	16.408.63.20.KKB	30565354

Dimensions in mm.

Basic form AD. Please indicate form AF (prev. B) in your order.

Spare parts and accessories at the end of this chapter. Custom designs available on request.



# HPH - High Performance Holder DIN 69893-HSK A

Short narrow design

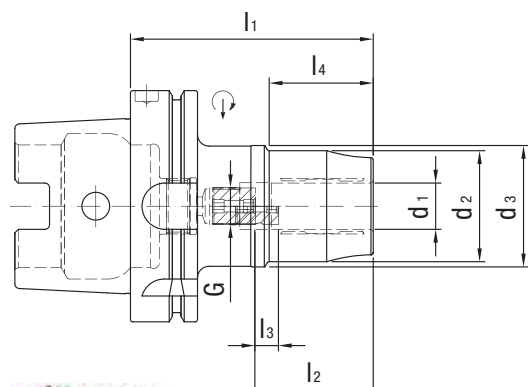

Nominal size HSK-A	Dimensions							G	sw	Weight [kg]	Order designation	Order No.
	d <sub>1</sub>	d <sub>2</sub>	d <sub>3</sub>	l <sub>1</sub>	l <sub>2</sub>	l <sub>3</sub>	l <sub>4</sub>					
100	6	32	50	85	37	10	26	M5x15	2.5	2.8	16.407.100.06.Z	30469210
100	8	34	50	85	37	10	27	M6x15	3	2.8	16.407.100.08.Z	30469216
100	10	36	50	90	41	10	32	M8x1x15.5	3	2.9	16.407.100.10.Z	30469218
100	12	38	52.5	95	46	10	37	M10x1x9.8	5	2.9	16.407.100.12.Z	30469220
100	14	40	52.5	95	46	10	37	M10x1x13	5	2.9	16.407.100.14.Z	30469221
100	16	42	52.5	100	49	10	42	M12x1x15	5	3	16.407.100.16.Z	30469222
100	18	44	52.5	100	49	10	42	M12x1x17	5	3	16.407.100.18.Z	30469229
100	20	48	52.5	105	51	10	45	M16x1x15.8	5	3	16.407.100.20.Z	30469233
100	25	57	63	115	57	10	60	M16x1x19.8	5	3.8	16.407.100.25.Z	30469234
100	32	63	75	120	61	10	60	M16x1x25.8	5	4	16.407.100.32.Z	30469236

Dimensions in mm.

Spare parts and accessories at the end of this chapter.

MQL-capable design possible on request. Custom designs available on request.



# HPH - High Performance Holder DIN 69893-HSK A

Short heavy duty design

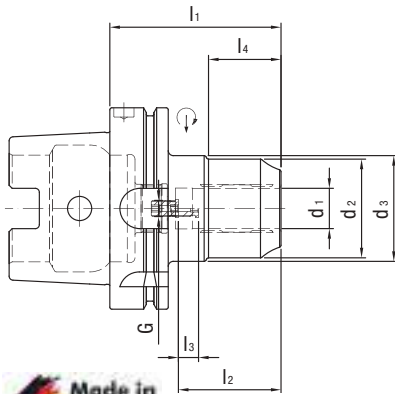

Nominal size HSK-A	Dimensions							G	sw	Weight [kg]	Order designation	Order No.
	d <sub>1</sub>	d <sub>2</sub>	d <sub>3</sub>	l <sub>1</sub>	l <sub>2</sub>	l <sub>3</sub>	l <sub>4</sub>					
100	12	42	52.5	85	46	10	34	M8x1	3	2.1	16.408.100.12.Z	30515435
100	20	49	52.5	85	51	10	36	M8x1	3	2.6	16.408.100.20.Z	30436113
100	32	68	72	100	61	10	42	M8x1	3	3.8	16.408.100.32.Z	30471219

Dimensions in mm.

Spare parts and accessories at the end of this chapter.

MQL-capable design possible on request. Custom designs available on request.



# HPH - High Performance Holder

## HPH 3° MULTI, BT MAS

Ultra-narrow design, coolant supply as per ISO 7388-2, Form JD/JF

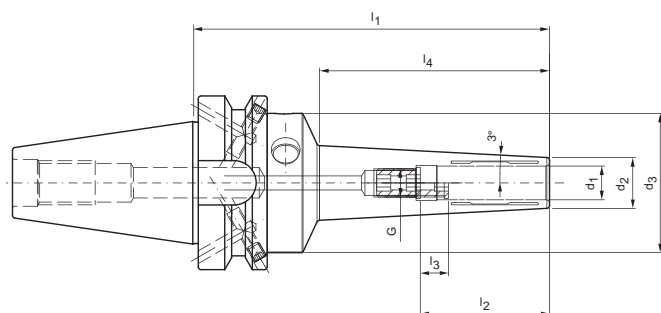

Nominal size BT	Dimensions							G	sw	Weight [kg]	Order designation	Order No.
	d <sub>1</sub>	d <sub>2</sub>	d <sub>3</sub>	l <sub>1</sub>	l <sub>2</sub>	l <sub>3</sub>	l <sub>4</sub>					
40	6	12	49.5	120	37	10	71.9	M5	2.5	1.3	22.404.40.06.Z.120	30756850
40	8	14	49.5	120	37	10	72.4	M6	3	1.3	22.404.40.08.Z.120	30756851
40	10	16	49.5	120	41	10	72.9	M8x1	3	1.3	22.404.40.10.Z.120	30756852
40	12	18	49.5	120	46	10	73.4	M10x1	5	1.3	22.404.40.12.Z.120	30756853

Dimensions in mm.

Basic form JD. Please indicate form JF (prev. B) in your order.

Spare parts and accessories at the end of this chapter.

Version with face connection on request. Custom designs available on request.



# HPH - High Performance Holder BT MAS

Short narrow design, coolant supply as per ISO 7388-2, Form JD/JF

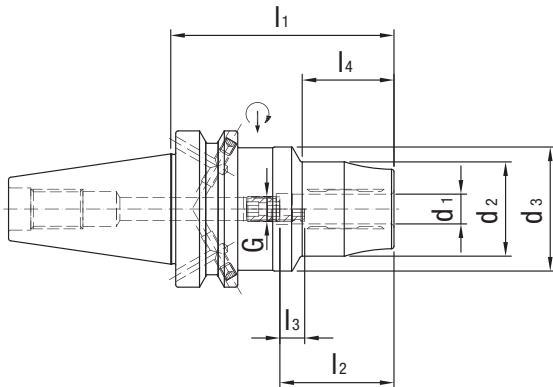

Nominal size BT	Dimensions							G	sw	Weight [kg]	Order designation	Order No.
	d <sub>1</sub>	d <sub>2</sub>	d <sub>3</sub>	l <sub>1</sub>	l <sub>2</sub>	l <sub>3</sub>	l <sub>4</sub>					
40	6	32	50	80	37	10	26	M5x12.5	2.5	1.6	22.407.40.06.Z	30466220
40	8	34	50	80	37	10	27	M6x12.5	3	1.6	22.407.40.08.Z	30466222
40	10	36	50	85	41	10	32	M8x1x13.5	3	1.6	22.407.40.10.Z	30466224
40	12	38	50	90	46	10	37	M10x1x13.5	5	1.7	22.407.40.12.Z	30466234
40	14	40	50	90	46	10	37	M10x1x13.5	5	1.8	22.407.40.14.Z	30466239
40	16	42	50	95	49	10	42	M12x1x13.5	5	1.8	22.407.40.16.Z	30466242
40	18	44	50	95	49	10	42	M12x1x13.5	5	1.9	22.407.40.18.Z	30466244
40	20	48	50	100	51	10	45	M16x1x13.5	8	1.9	22.407.40.20.Z	30466246
40	25	57	52	110	57	10	60	M16x1x13.5	8	2.4	22.407.40.25.Z	30466250
40	32	63	62	120	61	10	65	M16x1x13.5	8	2.7	22.407.40.32.Z	30466252

Dimensions in mm.

Basic form JD. Please indicate form JF (prev. B) in your order.

Spare parts and accessories at the end of this chapter.

Version with face connection on request. Custom designs available on request.





# HPH - High Performance Holder BT MAS

Short heavy duty design, coolant supply as per ISO 7388-2, Form JD/JF

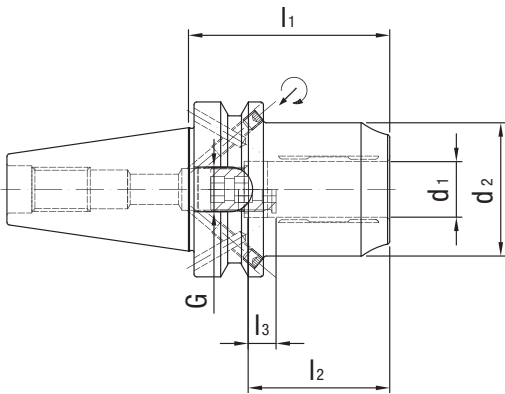

Nominal size BT	Dimensions					G	sw	Weight [kg]	Order designation	Order No.
	d <sub>1</sub>	d <sub>2</sub>	l <sub>1</sub>	l <sub>2</sub>	l <sub>3</sub>					
40	12	42	58	46	10	M8x1x13.5	3	1.1	22.408.40.12.Z	30494128
40	20	49	72.5	51	10	M16x1x13.5	8	1.4	22.408.40.20.Z	30372364

Dimensions in mm.

Basic form JD. Please indicate form JF (prev. B) in your order.

Spare parts and accessories at the end of this chapter.

Version with face connection on request. Custom designs available on request.



## HPH - High Performance Holder BT MAS

Short heavy duty design, coolant supply as per ISO 7388-2, Form JD/JF, with resealable coolant duct holes

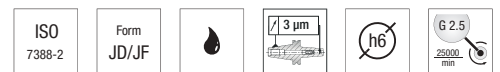
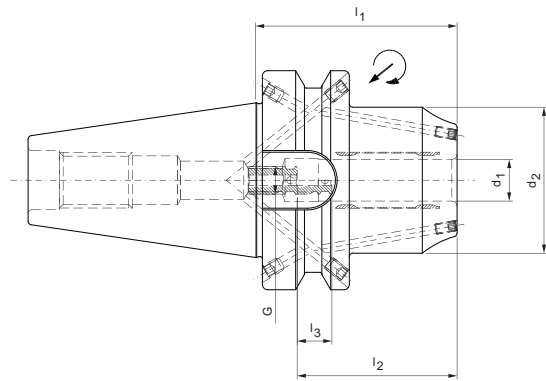

Nominal size BT	Dimensions					G	sw	Weight [kg]	Order designation	Order No.
	d <sub>1</sub>	d <sub>2</sub>	l <sub>1</sub>	l <sub>2</sub>	l <sub>3</sub>					
40	12	42	58	46	10	M8x1	3	1.1	22.408.40.12.KKB	30565357
40	16	46	72.5	49	10	M12x1	5	1.3	22.408.40.16.KKB	30565359
40	20	49	72.5	51	10	M16x1	8	1.6	22.408.40.20.KKB	30565361

Dimensions in mm.

Basic form JD. Please indicate form JF (prev. B) in your order.

Spare parts and accessories at the end of this chapter.

Version with face connection on request. Custom designs available on request.



# HPH - High Performance Holder BT MAS

Short heavy duty design, coolant supply as per ISO 7388-2, Form JD/JF

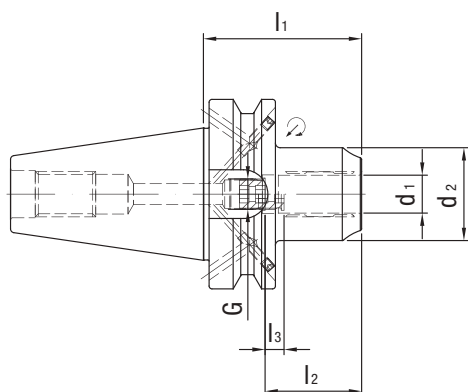

Nominal size BT	Dimensions					G	sw	Weight [kg]	Order designation	Order No.
	d <sub>1</sub>	d <sub>2</sub>	l <sub>1</sub>	l <sub>2</sub>	l <sub>3</sub>					
50	12	42	69	46	10	M8x1x13.5	3	3.4	22.408.50.12.Z	30515438
50	20	49	83.5	51	10	M16x1x13.5	8	4	22.408.50.20.Z	30435871
50	32	72	90	61	10	M16x1x13.5	8	4.6	22.408.50.32.Z	30471206

Dimensions in mm.

Basic form JD. Please indicate form JF (prev. B) in your order.

Spare parts and accessories at the end of this chapter.

Version with face connection on request. Custom designs available on request.



## Pressure Screw HPH

For pressure input. High-strength pressure screws - for safe acceptance of high clamping forces  
Coated pressure screws DLC - for optimum wear protection and long service life

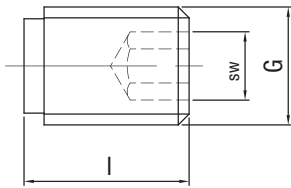

Order designation	Order No.	G	sw	l	Weight [kg]
89.122.288	10003470	M10	5	10	0.006
89.122.287	10070217	M10	5	14	0.009

### Allocation of Pressure Screw HPH

Order designation	Order No.	G	sw	l	For High Performance Holder
89.122.288	10003470	M10	5	10	16.408.63.20.Z; 16.408.100.20.Z; 16.408.63.12.Z; 16.408.100.12.Z
89.122.287	10070217	M10	5	14	Others

Dimensions in mm.



## Stop Screw HPH

For length adjustment

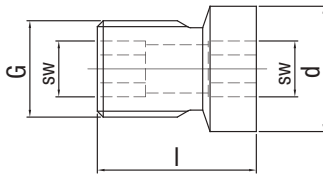

### Stop Screw HPH for HSK-A63; HSK-A100; SK40

Order designation	Order No.	G	sw	For clamping diameter	d	l	Weight [kg]
89.122.119	30340240	M5	2.5	6	5.5	15	0.001
89.122.120	30340241	M6	3	8	7	15	0.002
89.122.121	30340242	M8x1	3	10	9	15.5	0.005
89.122.122	30340243	M10x1	5	12	9.8	15.5	0.006
89.122.123	30340244	M10x1	5	14	13	16.5	0.008
89.122.124	30340245	M12x1	5	16	15	18	0.015
89.122.125	30340246	M12x1	5	18	17	20	0.02
89.122.126	30340247	M16x1	5	20	15.8	18.5	0.03
89.122.127	30340249	M16x1	5	25	19.8	22	0.05
89.122.128	30340250	M16x1	5	32	25.8	25	0.07

### Stop Screw HPH for BT40

Only "wet" design - thus short cantilever length

Order designation	Order No.	G	sw	For clamping diameter	d	l	Weight [kg]
89.122.88	30252539	M5	2.5	6	5.5	12.5	0.001
89.122.89	30252540	M6	3	8	7	12.5	0.002
89.122.23	30252541	M8x1	3	10	9	13.5	0.004
89.122.90	30252542	M10x1	5	12	9.8	13.5	0.006
89.122.90	30252542	M10x1	5	14	9.8	13.5	0.006
89.122.24	30252543	M12x1	5	16	13	13.5	0.011
89.122.24	30252543	M12x1	5	18	13	13.5	0.011
89.122.91	30252547	M16x1	8	20	15.8	13.5	0.021
89.122.91	30252547	M16x1	8	25	15.8	13.5	0.021
89.122.91	30252547	M16x1	8	32	15.8	13.5	0.021

### Stop Screw HPH for short heavy duty design

Only "wet" design - thus short cantilever length

Order designation	Order No.	G	sw	For clamping diameter
89.122.23	30252541	M8x1	3	20 (HSK)
89.122.91	30252547	M16x1	8	20 (ISO/BT)

Dimensions in mm.

Custom designs available on request.



## Reducing Sleeve, coolant sealed

With slits, for flexible diameter application

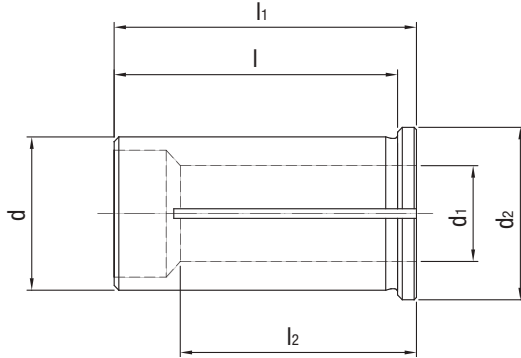

Dimensions							Order designation	Order No.
d	d <sub>1</sub>	d <sub>2</sub>	l	l <sub>1</sub>	l <sub>2</sub>	Weight [kg]		
12	1	16	40	44	20	0.04	40.456.12.01.Z	30503691
12	1.5	16	40	44	20	0.04	40.456.12.015.Z	30503718
12	2	16	40	44	20	0.04	40.456.12.02.Z	30503725
12	2.5	16	40	44	20	0.04	40.456.12.025.Z	30503728
12	3	16	40	44	29	0.03	40.456.12.03.Z	30251059
12	4	16	40	44	29	0.03	40.456.12.04.Z	30251060
12	5	16	40	44	29	0.03	40.456.12.05.Z	30251061
12	6	16	40	44	36	0.03	40.456.12.06.Z	30251062
12	7	16	40	44	37	0.03	40.456.12.07.Z	30251063
12	8	16	40	44	37	0.02	40.456.12.08.Z	30251064
12	9	16	40	44	37	0.02	40.456.12.09.Z	30251065
12	10	16	40	44	40	0.01	40.456.12.10.Z	30251066
20	3	25	50	54	28	0.1	40.456.20.03.Z	30251067
20	4	25	50	54	28	0.1	40.456.20.04.Z	30251068
20	5	25	50	54	28	0.1	40.456.20.05.Z	30251069
20	6	25	50	54	36	0.1	40.456.20.06.Z	30251070
20	7	25	50	54	38	0.1	40.456.20.07.Z	30251071
20	8	25	50	54	37	0.09	40.456.20.08.Z	30251072
20	9	25	50	54	38	0.09	40.456.20.09.Z	30251073
20	10	25	50	54	40	0.09	40.456.20.10.Z	30251074
20	11	25	50	54	40	0.08	40.456.20.11.Z	30251075
20	12	25	50	54	45	0.08	40.456.20.12.Z	30251076
20	13	25	50	54	45	0.07	40.456.20.13.Z	30251077
20	14	25	50	54	45	0.07	40.456.20.14.Z	30251078
20	15	25	50	54	45	0.06	40.456.20.15.Z	30251079
20	16	25	50	54	48	0.05	40.456.20.16.Z	30251080

Caution: Never clamp without tool - the reducing sleeve will be damaged!

# Reducing Sleeve, coolant sealed

With slits, for flexible diameter application

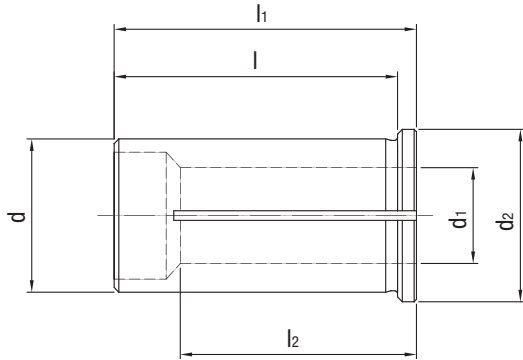

Dimensions							Order designation	Order No.
d	d <sub>1</sub>	d <sub>2</sub>	l	l <sub>1</sub>	l <sub>2</sub>	Weight [kg]		
25	3	30	56	60	29	0.18	40.456.25.03.Z	30251081
25	4	30	56	60	29	0.18	40.456.25.04.Z	30251082
25	5	30	56	60	29	0.18	40.456.25.05.Z	30251083
25	6	30	56	60	37	0.18	40.456.25.06.Z	30251084
25	7	30	56	60	37	0.18	40.456.25.07.Z	30251085
25	8	30	56	60	37	0.17	40.456.25.08.Z	30251086
25	9	30	56	60	38	0.17	40.456.25.09.Z	30251087
25	10	30	56	60	40	0.16	40.456.25.10.Z	30251088
25	12	30	56	60	46	0.15	40.456.25.12.Z	30251089
25	14	30	56	60	47	0.14	40.456.25.14.Z	30251090
25	16	30	56	60	48	0.13	40.456.25.16.Z	30251091
25	18	30	56	60	48	0.11	40.456.25.18.Z	30251092
25	20	30	56	60	50	0.09	40.456.25.20.Z	30251093
32	6	36	60	64	36	0.31	40.456.32.06.Z	30251094
32	7	36	60	64	37	0.31	40.456.32.07.Z	30251095
32	8	36	60	64	36	0.3	40.456.32.08.Z	30251096
32	9	36	60	64	37	0.3	40.456.32.09.Z	30251097
32	10	36	60	64	40	0.29	40.456.32.10.Z	30251098
32	11	36	60	64	40	0.28	40.456.32.11.Z	30251099
32	12	36	60	64	45	0.28	40.456.32.12.Z	30251100
32	13	36	60	64	45	0.28	40.456.32.13.Z	30251101
32	14	36	60	64	46	0.27	40.456.32.14.Z	30251102
32	15	36	60	64	46	0.26	40.456.32.15.Z	30251103
32	16	36	60	64	48	0.26	40.456.32.16.Z	30251104
32	17	36	60	64	48	0.25	40.456.32.17.Z	30251105
32	18	36	60	64	49	0.24	40.456.32.18.Z	30251106
32	19	36	60	64	49	0.23	40.456.32.19.Z	30251107
32	20	36	60	64	50	0.22	40.456.32.20.Z	30251108
32	22	36	60	64	50	0.19	40.456.32.22.Z	30251109
32	25	36	60	64	56	0.15	40.456.32.25.Z	30251110

Caution: Never clamp without tool - the reducing sleeve will be damaged!

Dimensions in mm.



## Reducing Sleeve, KKB

With coolant bores, for flexible diameter application

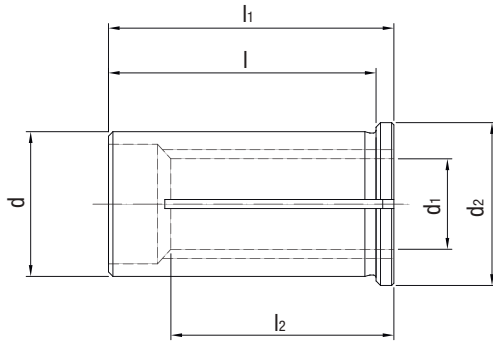

Dimensions							Order designation	Order No.
d	d <sub>1</sub>	d <sub>2</sub>	l	l <sub>1</sub>	l <sub>2</sub>	Weight [kg]		
12	3	16	40	44	29	0.03	40.456.12.03.KKB	30557343
12	4	16	40	44	29	0.03	40.456.12.04.KKB	30557344
12	5	16	40	44	29	0.03	40.456.12.05.KKB	30557345
12	6	16	40	44	36	0.03	40.456.12.06.KKB	30557346
12	8	16	40	44	37	0.02	40.456.12.08.KKB	30557347
20	3	25	50	54	28	0.1	40.456.20.03.KKB	30557348
20	4	25	50	54	28	0.1	40.456.20.04.KKB	30557350
20	5	25	50	54	28	0.1	40.456.20.05.KKB	30557351
20	6	25	50	54	36	0.1	40.456.20.06.KKB	30557352
20	8	25	50	54	37	0.09	40.456.20.08.KKB	30557353
20	10	25	50	54	40	0.09	40.456.20.10.KKB	30557354
20	12	25	50	54	45	0.08	40.456.20.12.KKB	30557355
20	14	25	50	54	45	0.07	40.456.20.14.KKB	30557356
20	16	25	50	54	48	0.05	40.456.20.16.KKB	30557358
32	6	36	60	64	36	0.31	40.456.32.06.KKB	30557359
32	8	36	60	64	36	0.3	40.456.32.08.KKB	30557360
32	10	36	60	64	40	0.29	40.456.32.10.KKB	30557361
32	12	36	60	64	45	0.28	40.456.32.12.KKB	30557362
32	14	36	60	64	46	0.27	40.456.32.14.KKB	30557364
32	16	36	60	64	48	0.26	40.456.32.16.KKB	30557365
32	18	36	60	64	49	0.24	40.456.32.18.KKB	30557366
32	20	36	60	64	50	0.22	40.456.32.20.KKB	30557367
32	25	36	60	64	56	0.15	40.456.32.25.KKB	30557369

Caution: Never clamp without tool - the reducing sleeve will be damaged!





## Shrink Extension

As flexible adaptation, length adjustment screw (from  $\varnothing$  6mm)

Tool length as per customer request possible

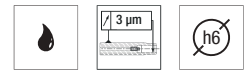
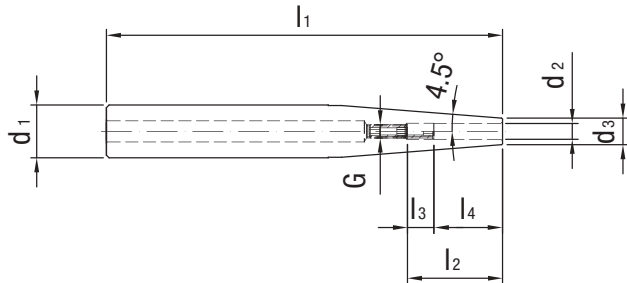

Dimensions							G	sw	Weight [kg]	Order designation	Order No.
d <sub>1</sub>	d <sub>2</sub>	d <sub>3</sub>	l <sub>1</sub>	l <sub>2</sub>	l <sub>3</sub>	l <sub>4</sub>					
12	3	8	150	-	-	12	-	0.1	-	40.357.12.03.Z	30344729
12	4	8	150	-	-	16	-	0.1	-	40.357.12.04.Z	30344730
12	5	10	150	-	-	20	-	0.1	-	40.357.12.05.Z	30344731
12	6	10	150	36	10	26	M5	2.5	0.1	40.357.12.06.Z	30344732
16	3	10	150	-	-	12	-	0.2	-	40.357.16.03.Z	30344733
16	4	10	150	-	-	16	-	0.2	-	40.357.16.04.Z	30344734
16	5	10	150	-	-	20	-	0.2	-	40.357.16.05.Z	30344735
16	6	10	150	36	10	26	M5	2.5	0.2	40.357.16.06.Z	30344736
16	8	12	150	36	10	26	M6	3	0.2	40.357.16.08.Z	30344737
20	3	10	150	-	-	12	-	0.3	-	40.357.20.03.Z	30344738
20	4	10	150	-	-	16	-	0.3	-	40.357.20.04.Z	30344739
20	5	10	150	-	-	20	-	0.3	-	40.357.20.05.Z	30344740
20	6	10	150	36	10	26	M5	2.5	0.3	40.357.20.06.Z	30344741
20	8	12	150	36	10	26	M6	3	0.3	40.357.20.08.Z	30344742
20	10	14	150	42	10	32	M8x1	3	0.3	40.357.20.10.Z	30344743
20	12	16	150	47	10	37	M10x1	5	0.3	40.357.20.12.Z	30344744

Dimensions in mm.



## Shrink Extension

As flexible adaptation, length adjustment screw (from  $\varnothing$  6mm)

Tool length as per customer request possible

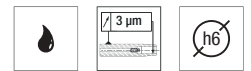
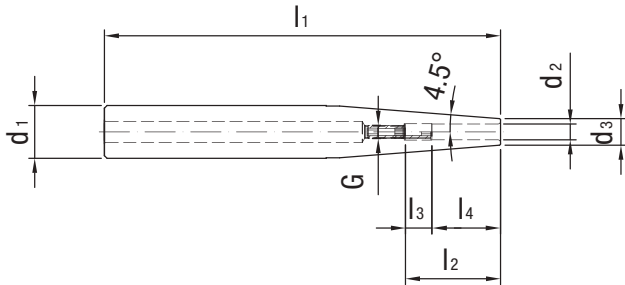

Dimensions							G	sw	Weight [kg]	Order designation	Order No.
d <sub>1</sub>	d <sub>2</sub>	d <sub>3</sub>	l <sub>1</sub>	l <sub>2</sub>	l <sub>3</sub>	l <sub>4</sub>					
25	3	10	150	-	-	12	-	0.5	-	40.357.25.03.Z	30344745
25	4	10	150	-	-	16	-	0.5	-	40.357.25.04.Z	30344746
25	5	15	150	-	-	20	-	0.5	-	40.357.25.05.Z	30344747
25	6	20	150	36	10	26	M5	2.5	0.5	40.357.25.06.Z	30344748
25	8	20	150	36	10	26	M6	3	0.5	40.357.25.08.Z	30344749
25	10	20	150	42	10	32	M8x1	3	0.5	40.357.25.10.Z	30344750
25	12	20	150	47	10	37	M10x1	5	0.5	40.357.25.12.Z	30344751
25	14	20	150	47	10	37	M10x1	5	0.4	40.357.25.14.Z	30344752
25	16	22	150	50	10	40	M10x1	5	0.4	40.357.25.16.Z	30344753
32	6	20	150	36	10	26	M5	2.5	0.8	40.357.32.06.Z	30344754
32	8	20	150	36	10	26	M6	3	0.8	40.357.32.08.Z	30344755
32	10	24	150	42	10	32	M8x1	3	0.8	40.357.32.10.Z	30344756
32	12	24	150	47	10	37	M10x1	5	0.8	40.357.32.12.Z	30344757
32	14	27	150	47	10	37	M10x1	5	0.8	40.357.32.14.Z	30344758
32	16	27	150	50	10	40	M10x1	5	0.8	40.357.32.16.Z	30344759
32	18	27	150	50	10	40	M10x1	5	0.7	40.357.32.18.Z	30337832
32	20	27	150	52	10	42	M10x1	5	0.7	40.357.32.20.Z	30337833

Dimensions in mm.

# AAS Stop Screw

With the use of WTE Reducing Sleeves for axial length adjustment

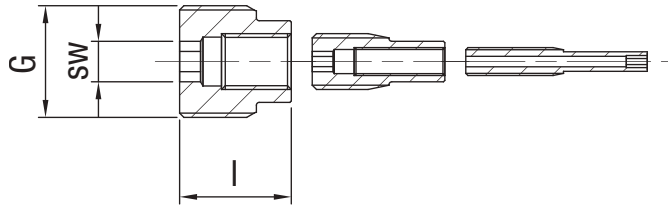

## Stop Screw AAS 12 for order designation 40.456.12.xx

Dimensions				Order designation	Order No.
G	sw	l	Weight [kg]		
M10x1	2.5	16	0.002	89.122.103	30308896
M4x0.5	1.5	26	0.001	89.122.101	30308901

## Stop Screw AAS 20 for order designation 40.456.20.xx

Dimensions				Order designation	Order No.
G	sw	l	Weight [kg]		
M16x1	5	16	0.002	89.122.99	30308897
M8x1	2.5	19	0.002	89.122.100	30308899
M4x0.5	1.5	26	0.001	89.122.101	30308901

## Stop Screw AAS 25 for order designation 40.456.25.xx

Dimensions				Order designation	Order No.
G	sw	l	Weight [kg]		
M16x1	5	20	0.002	89.122.104	30308904
M8x1	2.5	19	0.002	89.122.100	30308899
M4x0.5	1.5	26	0.001	89.122.101	30308901

## Stop Screw AAS 32 for order designation 40.456.32.xx

Dimensions				Order designation	Order No.
G	sw	l	Weight [kg]		
M16x1	5	20	0.002	89.122.104	30308904
M8x1	2.5	19	0.002	89.122.100	30308899

Dimensions in mm.



## Hydraulic Expansion Extension

As flexible adaptation

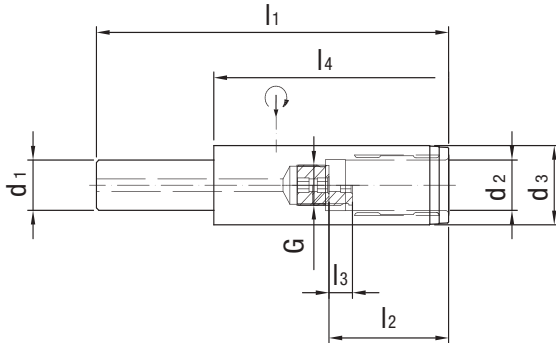

Dimensions							G	sw	Weight [kg]	Order designation	Order No.
d <sub>1</sub>	d <sub>2</sub>	d <sub>3</sub>	l <sub>1</sub>	l <sub>2</sub>	l <sub>3</sub>	l <sub>4</sub>					
20	12	25	150	46	10	100	M10x1	5	0.5	40.557.20.12.Z	30479021
20	20	31.5	150	51	10	100	M16x1	5	0.6	40.557.20.20.Z	30479022
32	20	31.5	150	51	10	90	M16x1	5	0.7	40.557.32.20.Z	30479024
32	20	31.5	200	51	10	90	M16x1	5	0.8	40.557.32.20.Z/200	30479025

## Coolant Transfer Pipe

For DIN 69893-HSK A/E

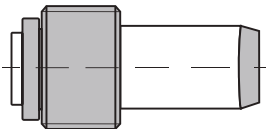

HSK	Weight [kg]	Order designation	Order No.
32	0.01	89.220.72	30326003
40	0.01	89.220.73	30326004
50	0.02	89.220.74	30326005
63	0.02	89.220.75	30326006
80	0.02	89.220.76	30326007
100	0.03	89.220.77	30326008

Dimensions in mm.



## Extraction Key

For easy extraction of the Reducing Sleeves from the WTE Hydraulic Chuck

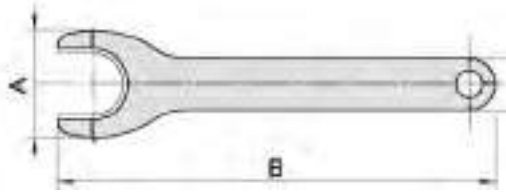

For	A	B	Order designation	Order No.
HS 12	24.6	100	89.206.26	30251198
HS 20	38	160	89.206.27	30251199
HS 25	51	180	89.206.28	30251200
HS 32	63	200	89.206.29	30251201

## Hexagonal T-key

For axial length adjustment

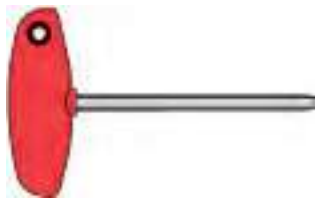

sw	l	Weight [kg]	Order designation	Order No.
2.5	150	0.02	89.206.01	10034540
3	150	0.02	89.206.02	10013347
5	150	0.06	89.206.03	10041807
8	150	0.1	89.206.04	10041808

Dimensions in mm.



## Assembly Key

For Coolant Transfer Pipe

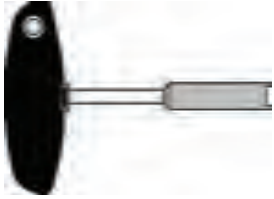

sw	Weight [kg]	Order designation	Order No.
32	0.01	89.206.20	10074750
40	0.01	89.206.21	10074751
50	0.01	89.206.22	10074752
63	0.01	89.206.23	10040110
80	0.02	89.206.24	10074774
100	0.02	89.206.25	10074775

## Hexagonal T-key

For pressure input

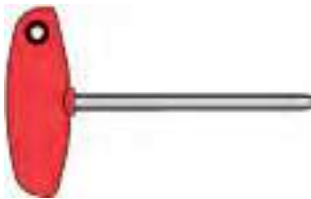

sw	l	Weight [kg]	Order designation	Order No.
5	100	0.06	89.206.15	10006236

Dimensions in mm.

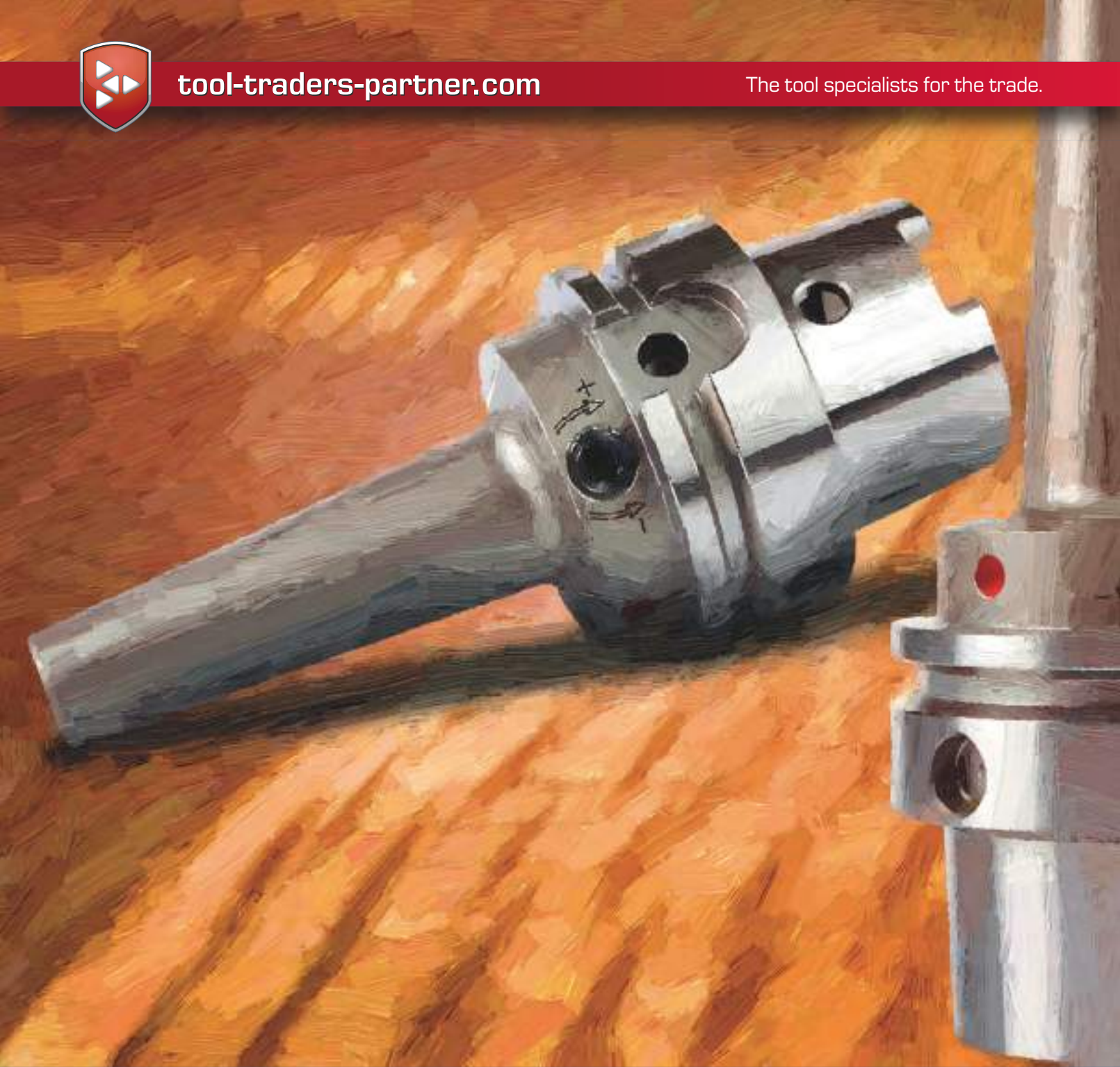

Standard Programme – High Performance Holder

## HPH 3° MULTI

# HPH – hydraulic chucking tech for special requirements!

## ADVANTAGE NO. 1

Slim 3° contour as on  
shrink adapters up to  
now

3°



High torque  
transmission

## ADVANTAGE NO. 2

Thermal stability up to  
120°C



Our arguments make the difference!  
Minimal tool restriction, high precision,  
excellent surfaces, for mould and tool making



nology



**ADVANTAGE NO. 3**

Long tool life

Optimal radial run-out <math>< 3 \mu\text{m}</math>



**ADVANTAGE NO. 4**

Very good vibration damping

Quick and easy chucking



**ADVANTAGE NO. 5**

Maximum flexibility due to usage of reducing sleeves



# HPH - High Performance Holder HPH 3° MULTI ISO 7388-1

(prev. DIN 69871-AD/B), narrow design, 3°, Form AD

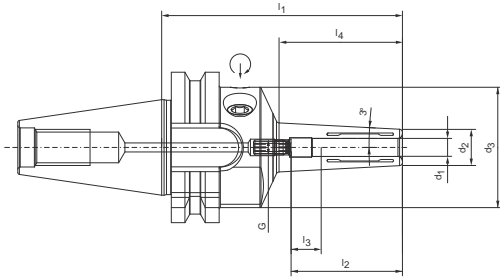

Nominal size SK	Dimensions							G	sw	Weight [kg]	Order designation	Order No.
	$d_1$	$d_2$	$d_3$	$l_1$	$l_2$	$l_3$	$l_4$					
30	3	9	40	80	28	16	40	M3	1,5	0,6	15.404.30.03.Z/80	30816303
30	4	10	40	80	28	12	40	M3	1,5	0,6	15.404.30.04.Z/80	30816304
30	5	11	40	80	28	8	41	M3	1,5	0,6	15.404.30.05.Z/80	30816305
30	6	12	40	80	37	10	41	M5	2,5	0,6	15.404.30.06.Z/80	30816307
30	8	14	40	80	37	10	41	M6	3	0,6	15.404.30.08.Z/80	30816308
30	10	16	40	80	41	10	42	M8x1	3	0,6	15.404.30.10.Z/80	30816311
30	12	18	40	80	46	10	42	M10x1	5	0,6	15.404.30.12.Z/80	30816312

# HPH - High Performance Holder HPH 3° MULTI ISO 7388-1

(prev. DIN 69871-AD/B), long narrow design, 3°, Form AD/AF

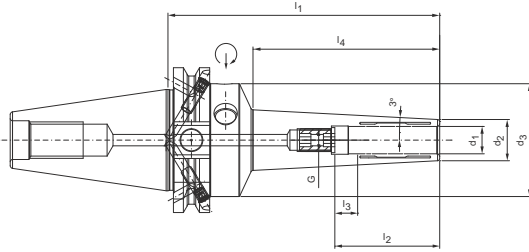

Nominal size SK	Dimensions							G	sw	Weight [kg]	Order designation	Order No.
	d <sub>1</sub>	d <sub>2</sub>	d <sub>3</sub>	l <sub>1</sub>	l <sub>2</sub>	l <sub>3</sub>	l <sub>4</sub>					
40	3	9	49,5	120	28	16	80	M2,5	1,3	1,1	15.404.40.03.Z/120	30777071
40	4	10	49,5	120	28	12	80	M2,5	1,3	1,2	15.404.40.04.Z/120	30777072
40	5	11	49,5	120	28	8	80	M2,5	1,3	1,2	15.404.40.05.Z/120	30777073
40	6	12	49,5	120	37	10	80	M5	2,5	1,2	15.404.40.06.Z/120	30655468
40	6	16	49,5	160	37	10	119	M5	2,5	1,6	15.404.40.06.Z/160	30816618
40	6	16	49,5	200	37	10	161	M5	2,5	1,9	15.404.40.06.Z/200	30816625
40	8	14	49,5	120	37	10	80	M6	3	1,2	15.404.40.08.Z/120	30655469
40	8	18	49,5	160	37	10	120	M6	3	1,6	15.404.40.08.Z/160	30816619
40	8	18	49,5	200	37	10	161	M6	3	2	15.404.40.08.Z/200	30816626
40	10	16	49,5	120	41	10	81	M8x1	3	1,2	15.404.40.10.Z/120	30655470
40	10	20	49,5	160	41	10	121	M8x1	3	1,7	15.404.40.10.Z/160	30816621
40	10	20	49,5	200	41	10	162	M8x1	3	2	15.404.40.10.Z/200	30816628
40	12	18	49,5	120	46	10	82	M10x1	5	1,2	15.404.40.12.Z/120	30655471
40	12	22	49,5	160	46	10	122	M10x1	5	1,8	15.404.40.12.Z/160	30816624
40	12	22	49,5	200	46	10	163	M10x1	5	2,2	15.404.40.12.Z/200	30816629
40	14	22	49,5	120	46	10	79	M10x1	5	1,3	15.404.40.14.Z/120	30782464
40	16	24	49,5	120	49	10	79	M12x1	5	1,3	15.404.40.16.Z/120	30782465
40	18	26	49,5	120	49	10	80	M12x1	5	1,4	15.404.40.18.Z/120	30782467
40	20	28	49,5	120	51	10	80	M16x1	5	1,4	15.404.40.20.Z/120	30782468

Dimensions in mm.

Basic form AD. Please indicate form AF (prev. B) in your order.

# HPH - High Performance Holder HPH 3° MULTI DIN 69893-A

Narrow design, 3°

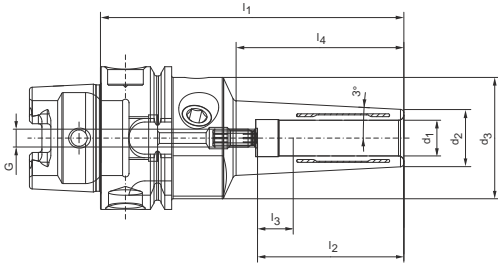

Nominal size HSK-A	Dimensions							G	sw	Weight [kg]	Order designation	Order No.
	$d_1$	$d_2$	$d_3$	$l_1$	$l_2$	$l_3$	$l_4$					
40	3	9	34	85	28	16	45	M2,5	1,3	0,3	16.404.40.03.Z/85	30817224
40	4	10	34	85	28	12	45	M2,5	1,3	0,3	16.404.40.04.Z/85	30817227
40	5	11	34	85	28	8	45	M2,5	1,3	0,3	16.404.40.05.Z/85	30817230
40	6	12	34	85	37	10	46	M5	2,5	0,3	16.404.40.06.Z/85	30817232
40	8	14	34	85	37	10	46	M6	3	0,4	16.404.40.08.Z/85	30817236
40	10	16	34	85	41	10	47	M5	2,5	0,4	16.404.40.10.Z/85	30817238
40	12	18	34	85	46	10	47	M5	2,5	0,4	16.404.40.12.Z/85	30817242

# HPH - High Performance Holder HPH 3° MULTI

## DIN 69893-A

Long narrow design, 3°

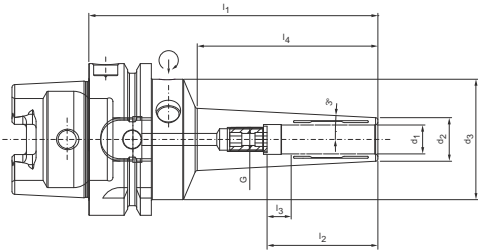

Nominal size HSK-A	Dimensions							G	sw	Weight [kg]	Order designation	Order No.
	d <sub>1</sub>	d <sub>2</sub>	d <sub>3</sub>	l <sub>1</sub>	l <sub>2</sub>	l <sub>3</sub>	l <sub>4</sub>					
63	3	9	50	120	28	16	73	M2,5	1,3	1	16.404.63.03.Z/120	30727351
63	4	10	50	120	28	12	73	M2,5	1,3	1	16.404.63.04.Z/120	30727356
63	5	11	50	120	28	8	73	M2,5	1,3	1	16.404.63.05.Z/120	30727359
63	6	12	50	120	37	10	73	M5	2,5	1	16.404.63.06.Z/120	30655463
63	6	16	50	160	37	10	111	M5	2,5	1,4	16.404.63.06.Z/160	30727381
63	6	16	50	200	37	10	152	M5	2,5	1,7	16.404.63.06.Z/200	30720821
63	7	13	50	120	37	10	74	M5	2,5	1	16.404.63.07.Z/120	30856764
63	8	14	50	120	37	10	74	M6	3	1	16.404.63.08.Z/120	30655465
63	8	18	50	160	37	10	111	M6	3	1,4	16.404.63.08.Z/160	30727383
63	8	18	50	200	37	10	152	M6	3	1,8	16.404.63.08.Z/200	30720823
63	9	15	50	120	37	10	74	M6	3	1	16.404.63.09.Z/120	30856766
63	10	16	50	120	41	10	74	M8x1	3	1	16.404.63.10.Z/120	30655466
63	10	20	50	160	41	10	113	M8x1	3	1,5	16.404.63.10.Z/160	30727385
63	10	20	50	200	41	10	154	M8x1	3	1,8	16.404.63.10.Z/200	30720824
63	11	17	50	120	41	10	74	M8x1	3	1	16.404.63.11.Z/120	30856768
63	12	18	50	120	46	10	75	M10x1	5	1	16.404.63.12.Z/120	30655467
63	12	22	50	160	46	10	113	M10x1	5	1,5	16.404.63.12.Z/160	30727390
63	12	22	50	200	46	10	154	M10x1	5	1,9	16.404.63.12.Z/200	30720825
63	13	20	50	120	46	10	75	M10x1	5	1,1	16.404.63.13.Z/120	30856770
63	14	22	50	120	46	10	71	M10x1	5	1,1	16.404.63.14.Z/120	30782387
63	16	24	50	120	49	10	72	M12x1	5	1,2	16.404.63.16.Z/120	30696274
63	18	26	50	120	49	10	72	M12x1	5	1,2	16.404.63.18.Z/120	30696276
63	20	28	50	120	51	10	72	M16x1	5	1,2	16.404.63.20.Z/120	30696278

# HPH - High Performance Holder HPH 3° MULTI DIN 69893-A

Narrow design, 3°

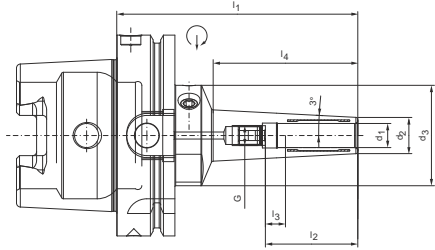

Nominal size HSK-A	Dimensions							G	sw	Weight [kg]	Order designation	Order No.
	d <sub>1</sub>	d <sub>2</sub>	d <sub>3</sub>	l <sub>1</sub>	l <sub>2</sub>	l <sub>3</sub>	l <sub>4</sub>					
100	3	9	50	120	28	16	70	M2,5	1,3	2,3	16.404.100.03.Z/120	30856775
100	4	10	50	120	28	12	70	M2,5	1,3	2,3	16.404.100.04.Z/120	30845043
100	5	11	50	120	28	8	70	M2,5	1,3	2,3	16.404.100.05.Z/120	30856776
100	6	12	50	120	37	10	70	M5	2,5	2,3	16.404.100.06.Z/120	30856777
100	7	13	50	120	37	10	70	M5	2,5	2,3	16.404.100.07.Z/120	30856778
100	8	14	50	120	37	10	71	M6	3	2,3	16.404.100.08.Z/120	30856779
100	9	15	50	120	37	10	71	M6	3	2,4	16.404.100.09.Z/120	30856780
100	10	16	50	120	41	10	71	M8x1	3	2,4	16.404.100.10.Z/120	30856781
100	11	17	50	120	41	10	71	M8x1	3	2,4	16.404.100.11.Z/120	30856782
100	12	18	50	120	46	10	72	M10x1	5	2,4	16.404.100.12.Z/120	30856783
100	13	20	50	120	46	10	72	M10x1	5	2,4	16.404.100.13.Z/120	30856784
100	14	22	50	120	46	10	68	M10x1	5	2,5	16.404.100.14.Z/120	30856785
100	16	24	50	120	49	10	68	M12x1	5	2,5	16.404.100.16.Z/120	30856786
100	18	26	50	120	49	10	69	M12x1	5	2,5	16.404.100.18.Z/120	30856787
100	20	28	50	120	51	10	69	M16x1	5	2,5	16.404.100.20.Z/120	30845056

# HPH - High Performance Holder HPH 3° MULTI DIN 69893-E

Narrow design, 3°

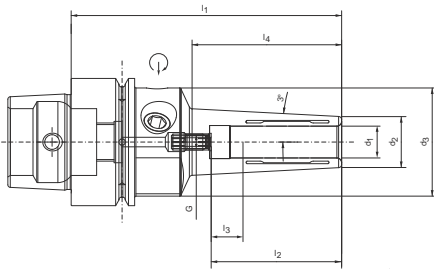

Nominal size HSK-E	Dimensions							G	sw	Weight [kg]	Order designation	Order No.
	d <sub>1</sub>	d <sub>2</sub>	d <sub>3</sub>	l <sub>1</sub>	l <sub>2</sub>	l <sub>3</sub>	l <sub>4</sub>					
40	3	9	34	85	28	16	45	M3	1,5	0,3	18.404.40.03.Z/85	30817154
40	4	10	34	85	28	12	45	M3	1,5	0,3	18.404.40.04.Z/85	30817157
40	5	11	34	85	28	8	45	M3	1,5	0,4	18.404.40.05.Z/85	30817158
40	6	12	34	85	37	10	46	M5	2,5	0,4	18.404.40.06.Z/85	30817160
40	8	14	34	85	37	10	46	M6	3	0,4	18.404.40.08.Z/85	30817161
40	10	16	34	85	41	10	47	M8x1	3	0,4	18.404.40.10.Z/85	30817162
40	12	18	34	85	46	10	47	M10x1	5	0,4	18.404.40.12.Z/85	30817165

# HPH - High Performance Holder HPH 3° MULTI DIN 69893-E

Narrow design, 3°

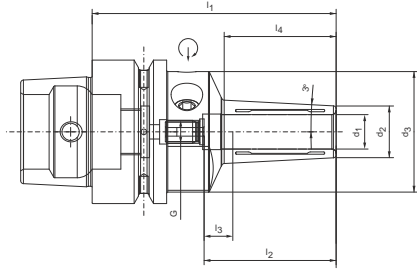

Nominal size HSK-E	Dimensions							G	sw	Weight [kg]	Order designation	Order No.
	$d_1$	$d_2$	$d_3$	$l_1$	$l_2$	$l_3$	$l_4$					
50	3	9	42	80	28	16	37	M3	1,5	0,6	18.404.50.03.Z/85	30817167
50	4	10	42	80	28	12	37	M3	1,5	0,6	18.404.50.04.Z/85	30817169
50	5	11	42	80	28	8	37	M3	1,5	0,6	18.404.50.05.Z/85	30817175
50	6	12	42	80	37	10	38	M5	2,5	0,6	18.404.50.06.Z/85	30817178
50	8	14	42	80	37	10	38	M6	3	0,6	18.404.50.08.Z/85	30817181
50	10	16	42	80	41	10	39	M8x1	3	0,6	18.404.50.10.Z/85	30817186
50	12	18	42	80	46	10	39	M10x1	5	0,6	18.404.50.12.Z/85	30817187



# HPH - High Performance Holder HPH 3° MULTI

## ISO 7388-2 (JIS B6339)

Narrow design, coolant supply as per ISO 7388-2, Form JD

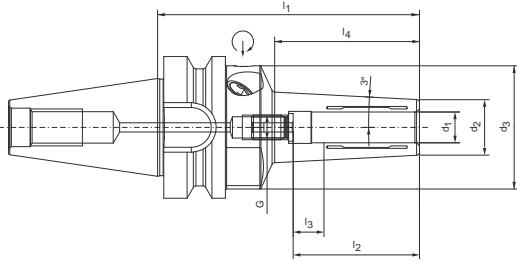

Nominal size BT	Dimensions							G	sw	Weight [kg]	Order designation	Order No.
	d <sub>1</sub>	d <sub>2</sub>	d <sub>3</sub>	l <sub>1</sub>	l <sub>2</sub>	l <sub>3</sub>	l <sub>4</sub>					
30	3	10	40	85	28	16	45	M3	1,5	0,6	22.404.30.03.Z/85	30818761
30	4	12	40	85	28	12	45	M3	1,5	0,6	22.404.30.04.Z/85	30818762
30	5	13	40	85	28	8	45	M3	1,5	0,6	22.404.30.05.Z/85	30818763
30	6	14	40	85	37	10	46	M5	2,5	0,6	22.404.30.06.Z/85	30818764
30	8	16	40	85	37	10	46	M6	3	0,7	22.404.30.08.Z/85	30818765
30	10	18	40	85	41	10	47	M8x1	3	0,7	22.404.30.10.Z/85	30818766
30	12	20	40	85	46	10	47	M8x1	3	0,7	22.404.30.12.Z/85	30818767
30	14	24	40	85	46	10	47	M8x1	3	0,7	22.404.30.14.Z/85	30818769
30	16	26	40	85	49	10	48	M8x1	3	0,7	22.404.30.16.Z/85	30818770
30	18	28	40	85	49	10	48	M8x1	3	0,7	22.404.30.18.Z/85	30818772
30	20	30	40	85	51	10	49	M8x1	3	0,7	22.404.30.20.Z/85	30818773

# HPH - High Performance Holder HPH 3° MULTI

## ISO 7388-2 (JIS B6339)

Long narrow design, coolant supply as per ISO 7388-2, Form JD/JF

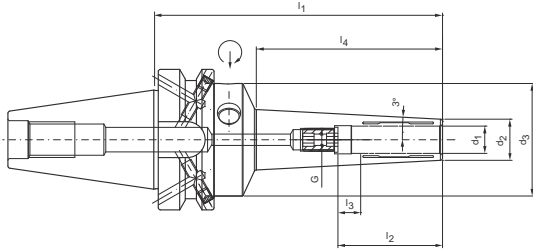

Nominal size BT	Dimensions							G	sw	Weight [kg]	Order designation	Order No.
	$d_1$	$d_2$	$d_3$	$l_1$	$l_2$	$l_3$	$l_4$					
40	3	9	49,5	120	28	16	72	M2,5	1,3	1,3	22.404.40.03.Z/120	30777235
40	4	10	49,5	120	28	12	72	M2,5	1,3	1,3	22.404.40.04.Z/120	30777237
40	5	11	49,5	120	28	8	72	M2,5	1,3	1,3	22.404.40.05.Z/120	30777238
40	6	12	49,5	120	37	10	72	M5	2,5	1,3	22.404.40.06.Z/120	30756850
40	6	16	49,5	160	37	10	111	M5	2,5	1,7	22.404.40.06.Z/160	30856803
40	6	16	49,5	200	37	10	153	M5	2,5	2	22.404.40.06.Z/200	30857105
40	8	14	49,5	120	37	10	72	M6	3	1,3	22.404.40.08.Z/120	30756851
40	8	18	49,5	160	37	10	112	M6	3	1,7	22.404.40.08.Z/160	30856804
40	8	18	49,5	200	37	10	153	M6	3	2	22.404.40.08.Z/200	30857106
40	10	16	49,5	120	41	10	73	M8x1	3	1,3	22.404.40.10.Z/120	30756852
40	10	20	49,5	160	41	10	113	M8x1	3	1,8	22.404.40.10.Z/160	30856806
40	10	20	49,5	200	41	10	154	M8x1	3	2,2	22.404.40.10.Z/200	30857112
40	12	18	49,5	120	46	10	74	M10x1	5	1,3	22.404.40.12.Z/120	30756853
40	12	22	49,5	160	46	10	114	M10x1	5	1,9	22.404.40.12.Z/160	30856808
40	12	22	49,5	200	46	10	155	M10x1	5	2,2	22.404.40.12.Z/200	30857114
40	14	22	49,5	120	46	10	71	M10x1	5	1,4	22.404.40.14.Z/120	30856795
40	16	24	49,5	120	49	10	71	M12x1	5	1,5	22.404.40.16.Z/120	30856796
40	18	26	49,5	120	49	10	72	M12x1	5	1,5	22.404.40.18.Z/120	30856797
40	20	28	49,5	120	51	10	72	M16x1	5	1,5	22.404.40.20.Z/120	30856799

Dimensions in mm.

Basic form JD. Please indicate form JF (prev. B) in your order.

# HPH - High Performance Holder HPH 3° MULTI ISO 7388-2 (JIS B6339)

Narrow design, 3° with face connection, Form JD

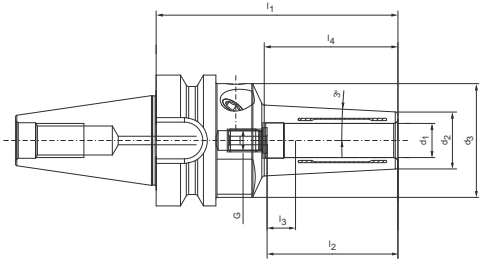

Nominal size BTFC	Dimensions							G	sw	Weight [kg]	Order designation	Order No.
	d <sub>1</sub>	d <sub>2</sub>	d <sub>3</sub>	l <sub>1</sub>	l <sub>2</sub>	l <sub>3</sub>	l <sub>4</sub>					
30	3	10	40	85	28	16	45	M3	1,5	0,6	27.404.30.03.Z/85	30818925
30	4	12	40	85	28	12	45	M3	1,5	0,6	27.404.30.04.Z/85	30818927
30	5	13	40	85	28	8	45	M3	1,5	0,6	27.404.30.05.Z/85	30818930
30	6	14	40	85	37	10	46	M5	2,5	0,6	27.404.30.06.Z/85	30818932
30	8	16	40	85	37	10	46	M6	3	0,6	27.404.30.08.Z/85	30818934
30	10	18	40	85	41	10	47	M8x1	3	0,6	27.404.30.10.Z/85	30818936
30	12	20	40	85	46	10	47	M8x1	3	0,6	27.404.30.12.Z/85	30818939
30	14	24	40	85	46	10	47	M8x1	3	0,7	27.404.30.14.Z/85	30818941
30	16	26	40	85	49	10	48	M8x1	3	0,7	27.404.30.16.Z/85	30818942
30	18	28	40	85	49	10	48	M8x1	3	0,7	27.404.30.18.Z/85	30818944
30	20	30	40	85	51	10	49	M8x1	3	0,7	27.404.30.20.Z/85	30818947

## Hydraulic clamping technology

### Application of WTE hydraulic clamping technologies



Our Hydraulic Chucks or HPH - High Performance Holder with axial and radial activated length adjustment can be used on wood and metal processing machines with rotating tools. There are different designs depending on the type of use, for example

Chucks for automatic tool change as per:  
ISO 7388-1 (DIN 69871); DIN 69893-A, DIN 69893-F, DIN 69893-E and  
ISO 7388-2 (JIS B6339)

Chucks for manual tool change as per:  
DIN 69893-C

### HPH 3° Multi - additively manufactured hydraulic clamping technology

WTE achieves a revolution in clamping technology with the new HPH technology with slender contour. For the first time it has become possible to utilise the benefits of a hydraulic chuck in an even wider field of applications. On the one hand, the new chuck has a slender contour with the 3° back taper known from the shrink chuck. On the other hand it offers the advantages of the WTE HPH (High Performance Holder). The new chuck offers significant benefits not only for mould making, but also for applications in the automotive and aerospace sector. Why? The HPH technology with slender contour is also suitable for all machining tasks in contour-critical areas.

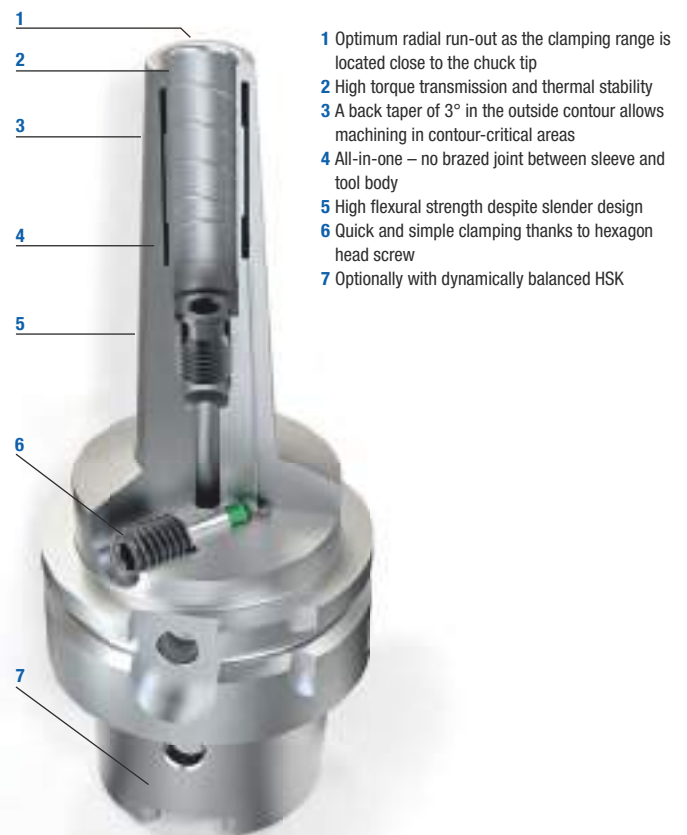

# WTE Comp-R

## The hydraulic chuck for special requirements!

The new chuck is based on proven WTE hydraulic expansion technology. In addition, the radial run-out can be set precisely with three adjustment elements. Wedges in the chuck serve to align the tool and, in turn, this prevents the tool from jamming. The system is self-locking and cannot become loose during fine machining. A fixed ring seals the alignment system.

As such, it requires very little maintenance and is not sensitive to dirt which results in an elongated tool life. Ideal form and position tolerances as well as high vibration damping are the further advantages of the new "Comp-R" chuck.



### ARGUMENTS

- Radial run-out accuracy adjustable to 0,000 mm
- The adjustment range is up to 0,015 mm
- Thermal stability up to 80° C
- Quick and easy chucking
- Straightforward and precise adjustment via adjusting screw

### AT A GLANCE

- Available in shank form HSK-A 63 und SK 50
- Ideal for reaming
- Chip version (Balluf chip) possible on request
- Uniform distribution of force
- Clamping range with h6 tolerance
- Can also be used with reducing sleeve

# WTE Hydros

## Hydraulic chucks – high holding forces, simple operation

High radial run-out accuracies and excellent vibration damping are the principal features of WTE hydraulic chucks. The use of WTE hydraulic chucks guarantees optimum workpiece finishes, long service life for the tools that are used and optimisation of the production process in terms of economical considerations.

WTE hydraulic chucks are available with both axial and radial length adjustment and are available in the standard range with the most commonly used shank forms. The use of reducing sleeves and special hydraulic chuck extensions also provides additional flexibility for this tool.

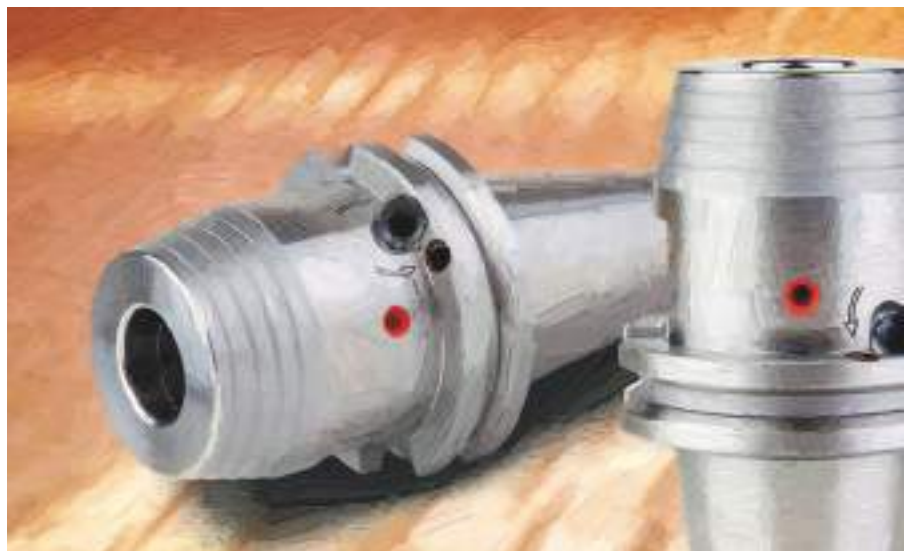

### ARGUMENTS

- High radial run-out accuracy (< 0,003 mm)
- Vibration damping effect
- High radial rigidity
- Clamping without additional equipment
- Fast set-up times possible
- Flexible clamping range due to reducing sleeves

### AT A GLANCE

- Available in all common shank forms
- Variant with radial or axial length adjustment possible
- Chip version (Balluf chip) possible for shank form SK and HSK-A
- MQL version also available on request

See detailed information at [www.wte-tools.de](http://www.wte-tools.de)



Your specialist for  
high accuracy chucks

Hydraulic Chucks  
HPH - High Performance Holder  
Shrink Chucks  
Precision CNC Drill Chucks  
Standard NC Drill Chucks  
MICRO Universal Chucks  
Services

[www.wte-tools.de](http://www.wte-tools.de)



Order No. 10149800 | V3.0.0