

B Technical Information for Auto Tools

Excellent for precision machining

Auto Tools

- High precision machining of small parts and complex forms, etc.
- High quality products through stable machining
- Exclusive insert for automatic lathes



▶ Type



▶ Application example

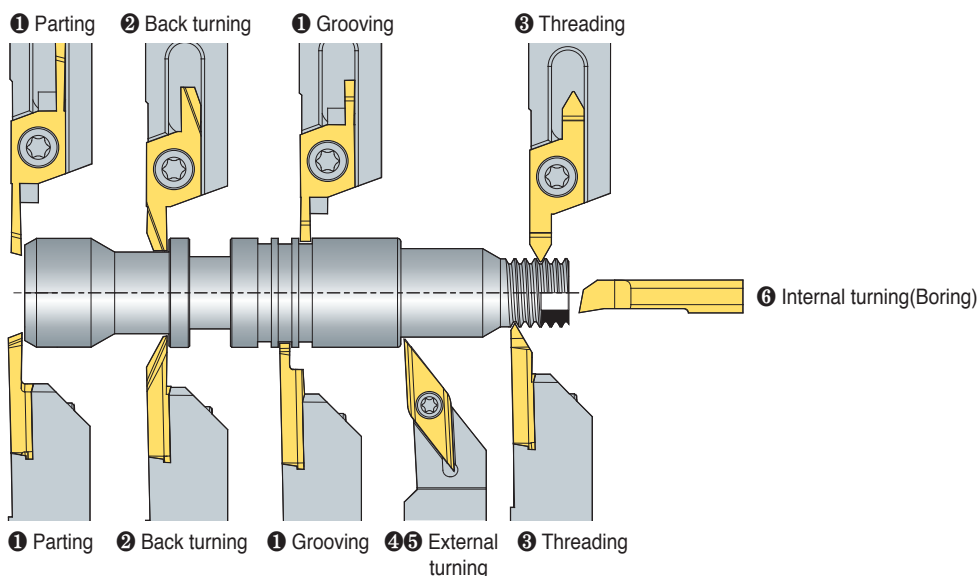

▶ Index

Specification	① Parting and Grooving						② Back turning			Specification	③ Threading	
Holder	SXGNR/L	SXGNR/L	MGEHR/L	SBHR/L	SBHR/L	MGEHR/L	SXGNR/L	SXGNR/L	SBHR/L	Holder	SXGNR/L	SBHR/L
Insert	SG	SC	MGMN	SBG	SBC	MGMN	SB	SGB	SBB	Insert	ST	SBT
Holder size	10~20mm	10~20mm	10~16mm	10~16mm	10~16mm	10~16mm	10~20mm	10~20mm	10~16mm	Holder size	10~20mm	10~16mm
Insert shape										Insert shape		
Cutting width	1~3mm	1~3mm	1.5~2.5mm	0.7~2.0mm	0.7~2.0mm	1.5~2.5mm	2~4mm	2~3mm	3.18mm	Screw ranges	Pitch ranges 0.5~1.5 / 1.5~3.0	Pitch ranges 0.2~1.5 / 1.0~2.0
ØDmax	Ø18	Ø18	Ø32	Ø16	Ø16	Ø32	Tmax 8	Tmax 8.5	Tmax 8.0	Insert	B185	B182
Page	B185	B185	B189	B182	B182	B189	B185	B185	B182			

Specification	④ External turning and Copy machining				⑤ External turning and Facing			Specification	⑥ Internal turning(Boring)				
Holder	SDJCR/L	SDNCN	SVJBR/L	SVJCR/L	SCACR/L	SCLCR/L	STACR/L	Holder	SCLCR/L	STUBR/L	STUPR/L	SWUBR/L	MSB
Insert	DC□□	DC□□	VB□□	VC□□	CC□□	CC□□	TC□□	Insert	CC□□	TB□□	TP□□	WB□□	-
Holder size	8~16mm	8~16mm	10~16mm	10~16mm	8~16mm	8~16mm	8~10mm	Shank diameter	Ø4~Ø10	Ø8	Ø8	Ø5~Ø8	Ø4~Ø6
Insert shape								Insert shape					
Feature	Offset "0"				Offset "0"			ØDmin	Ø5	Ø8	Ø10	Ø5.5	Ø3.2
Page	B177	B178	B178	B178	B177	B177	B178	Page	B150	B150	B150	B150	B192-B196



Auto Tools (ISO type)

- ▶ ISO inserts for automatic lathes
- ▶ Precise R shape with the use of minus tolerance of nose R
- ▶ Tolerance class precise enough in no need for adjusting tools with the use of accurate cutting edge height
- ▶ Sharp blade for excellent chip control and surface roughness with low cutting force
- ▶ High precision tools for electrical/ electronics instruments and medical instruments



▶ Code system (ISO type)

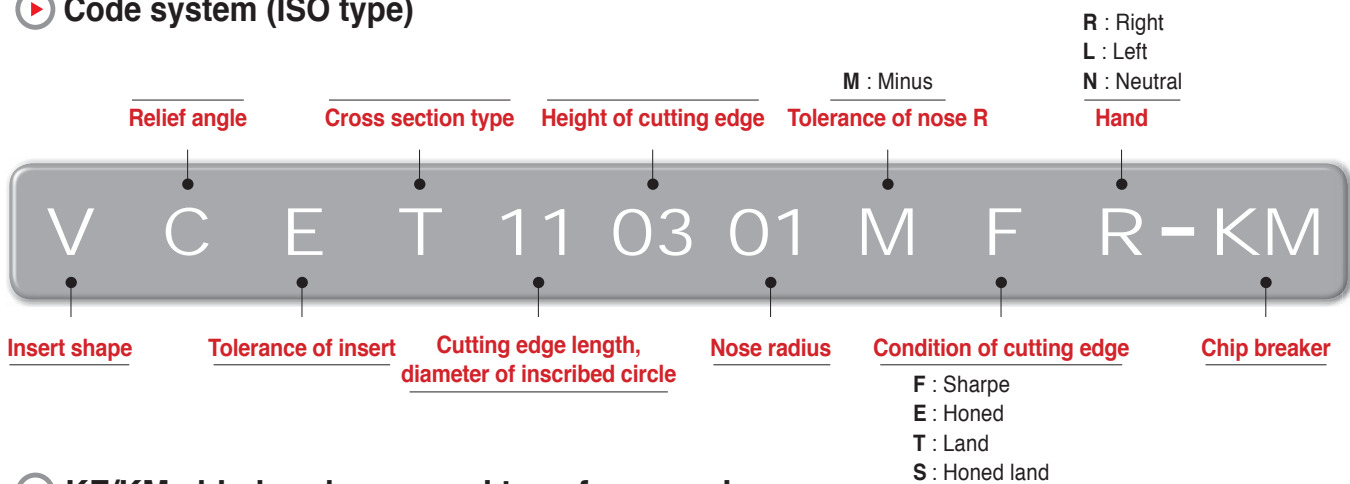

▶ KF/KM chip breaker, ground type for grooving

- Ground chip breaker with sharp cutting edge
- High precision insert of E-class tolerance with accurate nose radius

KF

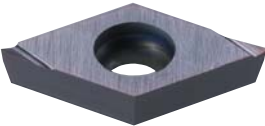

- For finishing
- Low cutting loads with sharp cutting edges
- Longer tool life due to lower chip evacuation resistance at high speed
- Excellent surface roughness

KM

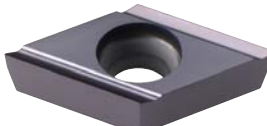

- For medium cutting to finishing
- Better chip flow due to wide chip pockets
- Longer tool life and better cutting action due to improved chip evacuation
- Excellent surface roughness

▶ VP1 chip breaker

- Exclusive chip breaker for hard-to-cut materials such as titanium alloy, Inconel, stainless steel, etc.
- Minimized cutting heat by reducing contact area between chips and rake surface with the use of high positive blade

VP1

- **Sharp cutting edge**
 - Excellent chip control
 - Low cutting resistance
 - High precision machining



- **High positive angle of rake surface**
 - Chip breaking at low depth of cut
 - Stable chip control at high depth of cut
 - Wide cutting area available with the use of optimized chip breaker width according to depth of cuts

SCACR/L

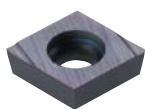

CC□T

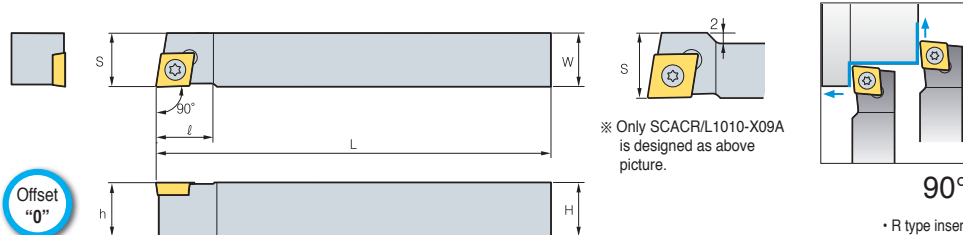

90°

• R type insert

(mm)

Designation	Stock		H	W	L	S	h	ℓ	Insert	Screw	Wrench
	R	L									
SCACR/L 0808-X06A	●		8	8	120	8	8	10	CC□T 0602 □□	FTKA02565	TW 07P
			10	10	120	10	10	10			
			10	10	120	12	10	13			
	●		12	12	120	12	12	16			
SCACR/L 1616-X09A	●		16	16	120	16	16	16	CC□T 09T3 □□	FTKA0410	TW 15P

➔ Applicable inserts, see pages B55 ~ 58, B80

● : Stock item

SCLCR/L

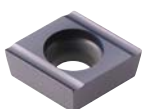

CC□T

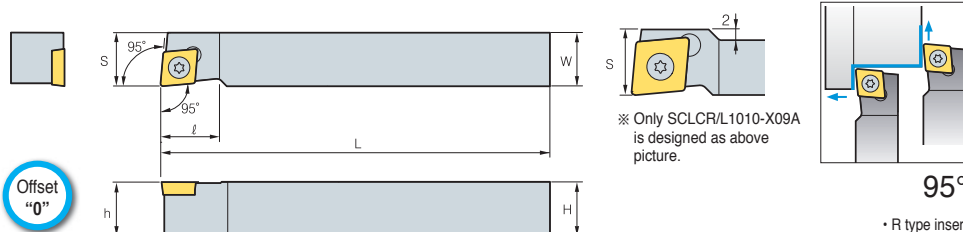

95°

• R type insert

(mm)

Designation	Stock		H	W	L	S	h	ℓ	Insert	Screw	Wrench
	R	L									
SCLCR/L 0808-X06A			8	8	120	8	8	10	CC□T 0602 □□	FTKA02565	TW 07P
	●		10	10	120	10	10	10			
			10	10	120	12	10	13			
	●		12	12	120	12	12	16			
SCLCR/L 1616-X09A			16	16	120	16	16	16	CC□T 09T3 □□	FTKA0410	TW 15P

➔ Applicable inserts, see pages B55 ~ 58, B80

● : Stock item

SDJCR/L

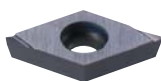

DC□T

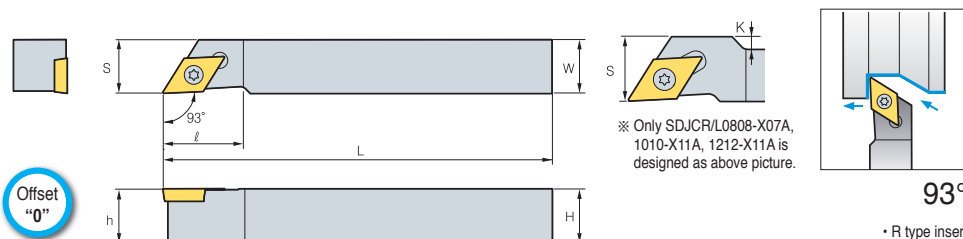

93°

• R type insert

(mm)

Designation	Stock		H	W	L	S	h	K	ℓ	Insert	Screw	Wrench
	R	L										
SDJCR/L 0808-X07A			8	8	120	10	8	2	18	DC□T 0702 □□	FTKA02565	TW 07P
	●		10	10	120	10	10	-	15			
	●		10	10	120	14	10	4	18			
	●		12	12	120	14	12	2	18			
	●		16	16	120	16	16	-	22			
SDJCR/L 1212-X11A			12	12	120	14	12	2	18	DC□T 11T3 □□	FTKA0410	TW 15P

➔ Applicable inserts, see pages B61 ~ 62, B81

● : Stock item



SDNCN



DC□T

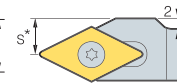
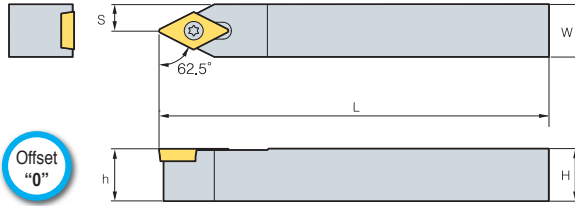

※ Only SDNCN1010-X11A is designed as above picture.

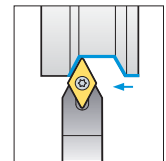

62.5°
(mm)

Designation	Stock	H	W	L	S	h	Insert	Screw	Wrench
SDNCN 0808-X07A		8	8	120	4	8	DC□T 0702 □□	FTKA02565	TW 07P
1010-X07A		10	10	120	5	10			
1010-X11A		10	10	120	7	10	DC□T 11T3 □□	FTKA0410	TW 15P
1212-X11A	●	12	12	120	6	12			
1616-X11A	●	16	16	120	8	16			

➡ Applicable inserts, see pages B61 ~ 62, B81

● : Stock item

STACR/L

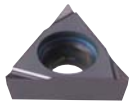

TC□T

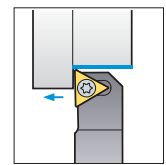
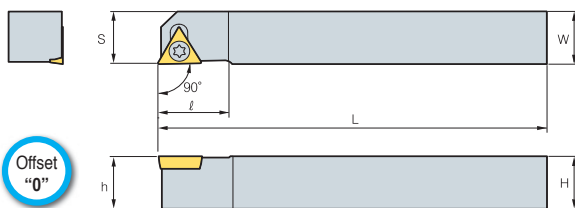

90°
• R type insert (mm)

Designation	Stock		H	W	L	S	h	K	ℓ	Insert	Screw	Wrench
	R	L										
STACR/L 0808-X08A			8	8	120	8	8	1	12	TC□T 0802 □□	FTNA 0206	TW 06P
1010-X08A			10	10	120	10	10	3	12			

➡ Applicable inserts, see pages B68

● : Stock item

SVJBR/L

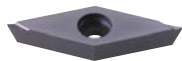

VB□T

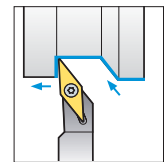
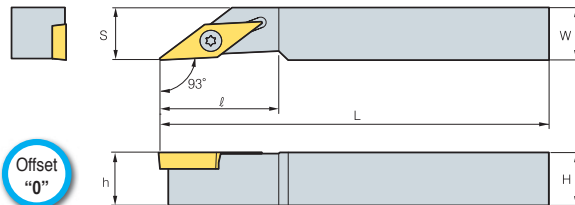

93°
• R type insert (mm)

Designation	Stock		H	W	L	S	h	ℓ	Insert	Screw	Wrench
	R	L									
SVJBR/L 1010-X11A			10	10	120	10	10	22	VB□T 1103 □□	FTKA 02565	TW 07P
1212-X11A	●		12	12	120	12	12	22			
1616-X11A			16	16	120	16	16	24			

➡ Applicable inserts, see pages B73 ~ B74, B85

● : Stock item

SVJCR/L

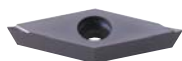

VC□T

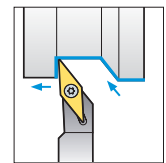
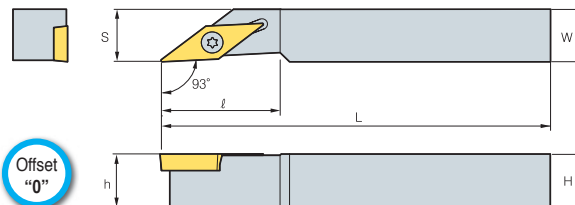

93°
• R type insert (mm)





Designation	Stock		H	W	L	S	h	ℓ	Insert	Screw	Wrench
	R	L									
SVJCR/L 1010-X11A			10	10	120	10	10	22	VC□T 1103 □□	FTKA 02565	TW 07P
1212-X11A	●		12	12	120	12	12	22			
1616-X11A			16	16	120	16	16	24			

➡ Applicable inserts, see pages B75 ~ 76, B86

● : Stock item

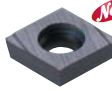
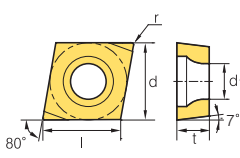
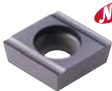
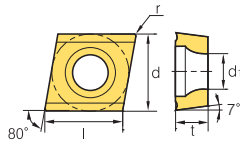
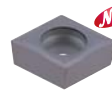
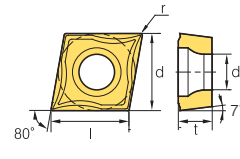
B Auto Tools (ISO Type)

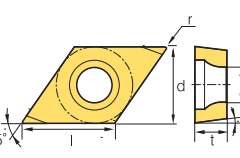
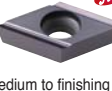
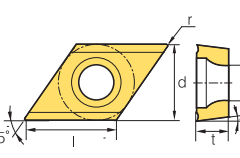

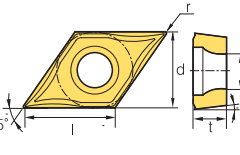







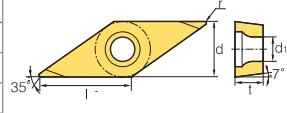

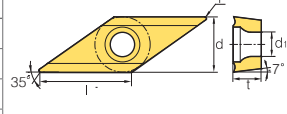
▶ Insert

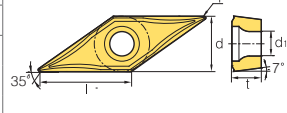
Picture	Designation	Cermet		Coated		Coated							Uncoated			Dimensions (mm)					Configuration					
		NC3220	NC3220	NC3220	NC3220	NC3010	NC3120	NC3220	NC3030	NC9020	NC9025	NC5330	PC8110	PC5300	PC9030	NC6205	NC6210	NC315K	U2	H01		G10E	l	d	t	r
 <p>Finishing (High precision)</p>	0602005MFR-KF																				6.6	6.35	2.38	0.05	2.8	
	060201MFR-KF										●										6.4	6.35	2.38	0.1	2.8	
	060202MFR-KF										●										6.2	6.35	2.38	0.2	2.8	
	09T3005MFR-KF																				9.8	9.525	3.97	0.05	4.4	
	09T301MFR-KF										●										9.6	9.525	3.97	0.1	4.4	
	09T302MFR-KF										●										9.2	9.525	3.97	0.2	4.4	
	0602005MFL-KF																				6.6	6.35	2.38	0.05	2.8	
	060201MFL-KF											●									6.4	6.35	2.38	0.1	2.8	
	060202MFL-KF											●									6.2	6.35	2.38	0.2	2.8	
	09T3005MFL-KF																				9.8	9.525	3.97	0.05	4.4	
09T301MFL-KF											●									9.6	9.525	3.97	0.1	4.4		
09T302MFL-KF											●									9.2	9.525	3.97	0.2	4.4		
 <p>Medium to finishing (High precision)</p>	0602005MFR-KM																				6.6	6.35	2.38	0.05	2.8	
	060201MFR-KM										●										6.4	6.35	2.38	0.1	2.8	
	060202MFR-KM										●										6.2	6.35	2.38	0.2	2.8	
	09T3005MFR-KM																				9.8	9.525	3.97	0.05	4.4	
	09T301MFR-KM										●										9.6	9.525	3.97	0.1	4.4	
	09T302MFR-KM										●										9.2	9.525	3.97	0.2	4.4	
	0602005MFL-KM																				6.6	6.35	2.38	0.05	2.8	
	060201MFL-KM											●									6.4	6.35	2.38	0.1	2.8	
	060202MFL-KM											●									6.2	6.35	2.38	0.2	2.8	
	09T3005MFL-KM																				9.8	9.525	3.97	0.05	4.4	
09T301MFL-KM											●									9.6	9.525	3.97	0.1	4.4		
09T302MFL-KM											●									9.2	9.525	3.97	0.2	4.4		
 <p>Finishing (High precision)</p>	060201MFN-VP1											●									6.6	6.35	2.38	2.8	0.1	
	060202MFN-VP1											●									6.4	6.35	2.38	2.8	0.2	
	060204MFN-VP1											●									6.2	6.35	2.38	2.8	0.4	
	09T301MFN-VP1											●									9.8	9.525	3.97	4.4	0.1	
	09T302MFN-VP1											●									9.6	9.525	3.97	4.4	0.2	
	09T304MFN-VP1											●									9.2	9.525	3.97	4.4	0.4	
 <p>Finishing (High precision)</p>	0702005MFR-KF																				7.8	6.35	2.38	0.05	2.8	
	070201MFR-KF											●									7.8	6.35	2.38	0.1	2.8	
	070202MFR-KF											●									7.8	6.35	2.38	0.2	2.8	
	11T3005MFR-KF																				11.6	9.525	3.97	0.05	4.4	
	11T301MFR-KF											●									11.6	9.525	3.97	0.1	4.4	
	11T302MFR-KF											●									11.6	9.525	3.97	0.2	4.4	
	0702005MFL-KF																				7.8	6.35	2.38	0.05	2.8	
	070201MFL-KF											●									7.8	6.35	2.38	0.1	2.8	
	070202MFL-KF												●								7.8	6.35	2.38	0.2	2.8	
	11T3005MFL-KF																				11.6	9.525	3.97	0.05	4.4	
11T301MFL-KF												●								11.6	9.525	3.97	0.1	4.4		
11T302MFL-KF												●								11.6	9.525	3.97	0.2	4.4		
 <p>Medium to finishing (High precision)</p>	0702005MFR-KM																				7.8	6.35	2.38	0.05	2.8	
	070201MFR-KM											●									7.8	6.35	2.38	0.1	2.8	
	070202MFR-KM											●									7.8	6.35	2.38	0.2	2.8	
	11T3005MFR-KM																				11.6	9.525	3.97	0.05	4.4	
	11T301MFR-KM											●									11.6	9.525	3.97	0.1	4.4	
	11T302MFR-KM											●									11.6	9.525	3.97	0.2	4.4	
	0702005MFL-KM																				7.8	6.35	2.38	0.05	2.8	
	070201MFL-KM											●									7.8	6.35	2.38	0.1	2.8	
	070202MFL-KM												●								7.8	6.35	2.38	0.2	2.8	
	11T3005MFL-KM																				11.6	9.525	3.97	0.05	4.4	
11T301MFL-KM												●								11.6	9.525	3.97	0.1	4.4		
11T302MFL-KM												●								11.6	9.525	3.97	0.2	4.4		
 <p>Finishing (High precision)</p>	070201MFN-VP1											●									7.8	6.35	0.1	2.38	2.8	
	070202MFN-VP1											●									7.8	6.35	0.2	2.38	2.8	
	070204MFN-VP1											●									7.8	6.35	0.4	2.38	2.8	
	11T301MFN-VP1											●									11.6	9.525	0.1	3.97	4.4	
	11T302MFN-VP1											●									11.6	9.525	0.2	3.97	4.4	
	11T304MFN-VP1											●									11.6	9.525	0.4	3.97	4.4	

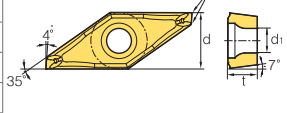
● : Stock item

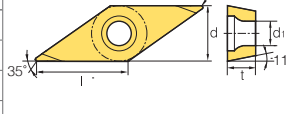

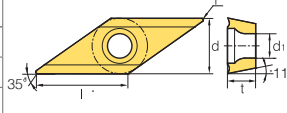
▶ Insert

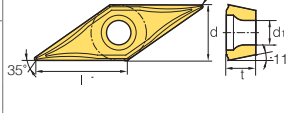
Picture	Designation	Cermet		Coated										Uncoated			Dimensions (mm)					Configuration			
		NC3220	NC3220	NC3220	NC3220	NC3010	NC3120	NC3220	NC3030	NC9020	NC5330	PC8110	PC5300	PC9030	NC6205	NC6210	NC315K	U2	H01	G10E	l		d	t	r
 <p>Finishing (High precision)</p>	1103005MFR-KF																			11.0	6.35	3.18	0.05	2.8	
	110301MFR-KF										●									11.0	6.35	3.18	0.1	2.8	
	110302MFR-KF											●								11.0	6.35	3.18	0.2	2.8	
	1103005MFL-KF																			11.0	6.35	3.18	0.05	2.8	
	110301MFL-KF																			11.0	6.35	3.18	0.1	2.8	
	110302MFL-KF																			11.0	6.35	3.18	0.2	2.8	
 <p>Medium to finishing (High precision)</p>	1103005MFR-KM																		11.0	6.35	3.18	0.05	2.8		
	110301MFR-KM										●								11.0	6.35	3.18	0.1	2.8		
	110302MFR-KM																		11.0	6.35	3.18	0.2	2.8		
	1103005MFL-KM																		11.0	6.35	3.18	0.05	2.8		
	110301MFL-KM																		11.0	6.35	3.18	0.1	2.8		
	110302MFL-KM																		11.0	6.35	3.18	0.2	2.8		
 <p>Finishing (High precision)</p>	110301MFN-VP1																		11.0	6.35	3.18	0.1	2.8		
	110302MFN-VP1																		11.0	6.35	3.18	0.2	2.8		
	110304MFN-VP1																		11.0	6.35	3.18	0.4	2.8		
 <p>Finishing (High precision)</p>	120300MFR-VP1																		11.0	7.50	3.18	0.0	2.8		
	120301MFR-VP1																		11.0	7.50	3.18	0.1	2.8		
	120302MFR-VP1																		11.0	7.50	3.18	0.2	2.8		
	120300MFL-VP1																		11.0	7.50	3.18	0.0	2.8		
	120301MFL-VP1																		11.0	7.50	3.18	0.1	2.8		
	120302MFL-VP1																		11.0	7.50	3.18	0.2	2.8		
 <p>Finishing (High precision)</p>	0802005MFR-KF																		8.0	6.35	2.38	0.1	2.3		
	080201MFR-KF																		8.0	6.35	2.38	0.1	2.3		
	080202MFR-KF																		8.0	6.35	2.38	0.2	2.3		
	080201MFL-KF																		8.0	6.35	2.38	0.1	2.3		
	080201MFL-KF																		8.0	6.35	2.38	0.1	2.3		
	080202MFL-KF																		8.0	6.35	2.38	0.2	2.3		
 <p>Medium to finishing (High precision)</p>	0802005MFR-KM																		8.0	6.35	2.38	0.1	2.3		
	080201MFR-KM																		8.0	6.35	2.38	0.1	2.3		
	080202MFR-KM																		8.0	6.35	2.38	0.2	2.3		
	0802005MFL-KM																		8.0	6.35	2.38	0.1	2.3		
	080201MFL-KM																		8.0	6.35	2.38	0.1	2.3		
	080202MFL-KM																		8.0	6.35	2.38	0.2	2.3		
 <p>Finishing (High precision)</p>	110301MFN-VP1																		11.0	6.35	3.18	0.1	2.8		
	110302MFN-VP1																		11.0	6.35	3.18	0.2	2.8		
	110304MFN-VP1																		11.0	6.35	3.18	0.4	2.8		

● : Stock item



B Auto Tools (Blade Type)

Auto tools (Blade type) *New*

- ▶ Blade insert for automatic lathes
- ▶ For external machining of precise small parts
- ▶ 4 types - SSB(for back turning), SGB(for grooving), SBT(for threading), SBC(for parting off)
- ▶ Convenient use of one holder to all blade inserts
- ▶ Exclusive holder for close cutting action to the sub spindle



▶ Code system of Auto tools insert (Blade type)

Turning (Back turning)	SB	B	R	25	10
	Small blade	Back turning	Hand R : Right L : Left	Length of insert	Nose radius
Grooving	SB	G	R	25	20
	Small blade	Grooving	Hand R : Right L : Left	Length of insert	Width of cutting edge
Threading	SB	T	R	25	60 - N - 010
	Small blade	Threading	Hand R : Right L : Left	Length of insert	Angle of thread Hand of thread R : Right L : Left N : None
Parting	SB	C	R	25	20
	Small blade	Parting off	Hand R : Right L : Left	Length of insert	Width of cutting edge Max. machining diameter Hand of thread R : Right L : Left N : None

▶ Code system of Auto tools holder (Blade type)

SB	H	R	10	10	K25	X
Small blade	Holder	Hand R : Right L : Left	Height of shank	Width of shank	Length of insert	sub spindle

▶ Types of blade insert

Possible to apply various types of blade inserts to one holder



SBB : For back turning

- Approach angle : 59°
- Max. cutting depth : 4mm
- Nose R : 0.05, 0.1, 0.2mm



SGB : For grooving

- Width : 0.5~2.5mm
- Nose R : 0.05mm



SBT : For threading

- V profile : 60°
- Pitch : 0.2~1.0mm
- Nose R : 0.05mm



SBC : For parting off

- Cutting width : 0.7~2.0
- D Max. : 16mm
- Nose R : 0.05mm



SBHR/L



SBBR SBGR
SBTR SBCR

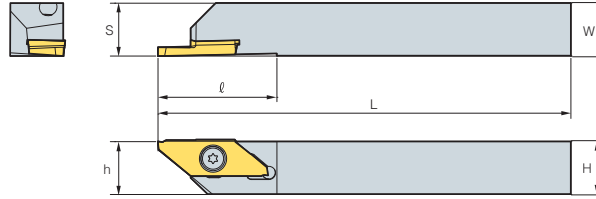

Designation	Stock		H	W	L	S	h	l	Insert	Screw	Wrench
	R	L									
SBHR/L	1010-K25	●	10	10	125	10	10	27	SB□R/L25	FTKA0409S	T9
	1212-K25	●	12	12	125	12	12	27			
	1616-K25	●	16	16	125	16	16	27			

● : Stock item

SBHR/L-X (sub spindle)



SBBR SBGR
SBTR SBCR

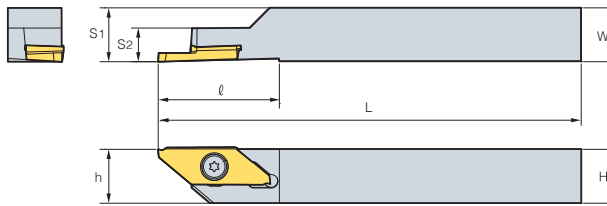

Designation	Stock		H	W	L	S ₁	S ₂	h	l	Insert	Screw	Wrench
	R	L										
SBHR/L	1010-K25-X	●	10	10	125	10	7.5	10	27	SB□R/L25	FTKA0407S	T9
	1212-K25-X	●	12	12	125	12	7.5	12	27			

● : Stock item

Insert

Application	Picture	Designation	Coated		Dimensions (mm)										Configuration	Feed direction		
			PC5300	PC8110	l	α	t	r	La	ar	f	D-MAX	Pitch					
													Min.	Max.				
Back turning		SBBR/L 25005	●	●	25	59	3.18	0.05	-	-	-	-	-	-	-	-		
		25010	●	●	25	59	3.18	0.10	-	-	-	-	-	-	-	-		
		25020	●	●	25	59	3.18	0.20	-	-	-	-	-	-	-	-		
Grooving		SBGR/L 2505	●	●	25	-	-	0.05	0.5	1.35	-	-	-	-	-	-		
		2510	●	●	25	-	-	0.05	1.0	2.75	-	-	-	-	-	-		
		2515	●	●	25	-	-	0.05	1.5	3.75	-	-	-	-	-	-		
		2520	●	●	25	-	-	0.05	2.0	3.75	-	-	-	-	-	-		
		2525	●	●	25	-	-	0.05	2.5	3.75	-	-	-	-	-	-		
Threading		SBTR/L 2560-N-005	●	●	25	-	-	0.05	-	-	1.59	-	0.2	2.0				
		2560-N-010	●	●	25	-	-	0.10	-	-	1.59	-	1.0	2.0				
		2560-R-005	●	●	25	-	-	0.05	-	-	0.6	-	0.2	1.5				
		2560-R-010	●	●	25	-	-	0.10	-	-	0.6	-	1.0	1.5				
		2560-L-005	●	●	25	-	-	0.05	-	-	0.6	-	0.2	1.5				
		2560-L-010	●	●	25	-	-	0.10	-	-	0.6	-	1.0	1.5				

● : Stock item



B Auto Tools (Blade Type)

▶ Insert

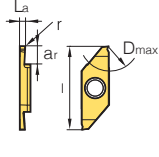
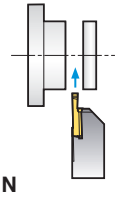
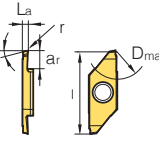
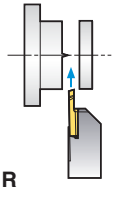
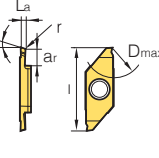
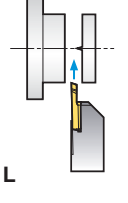
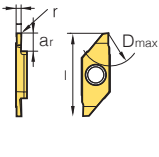
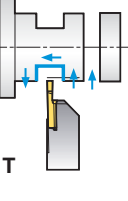
Application	Picture	Designation	Coated		Dimensions (mm)										Configuration	Feed direction
			PC5300	PC8110	l	α	t	r	La	ar	f	D-MAX	Pitch			
													Min.	Max.		
Parting off SBCR/L		SBCR/L 250708-N	●	●	25	0	-	0.05	0.70	4.3	-	8	-	-		
		251012-N	●	●	25	0	-	0.05	1.00	6.3	-	12	-	-		
		251512-N	●	●	25	0	-	0.05	1.50	6.3	-	12	-	-		
		252016-N	●	●	25	0	-	0.05	2.00	8.5	-	16	-	-		
		250708-R	●	●	25	15	-	0.05	0.70	4.3	-	8	-	-		
		251012-R	●	●	25	15	-	0.05	1.00	6.3	-	12	-	-		
		251512-R	●	●	25	15	-	0.05	1.50	6.3	-	12	-	-		
		252016-R	●	●	25	15	-	0.05	2.00	8.5	-	16	-	-		
		250708-L	●	●	25	15	-	0.05	0.70	4.3	-	8	-	-		
		251012-L	●	●	25	15	-	0.05	1.00	6.3	-	12	-	-		
		251512-L	●	●	25	15	-	0.05	1.50	6.3	-	12	-	-		
		252016-L	●	●	25	15	-	0.05	2.00	8.5	-	16	-	-		
		251012-T	●	●	25	0	-	0.05	1.00	6.3	-	12	-	-		
		251512-T	●	●	25	0	-	0.05	1.50	6.3	-	12	-	-		
		252016-T	●	●	25	0	-	0.05	2.00	8.5	-	16	-	-		

● : Stock item



Auto tools (For multi utility)

- ▶ Multifunctional insert for automatic lathes
- ▶ For external machining of precise small parts
- ▶ 5 types - SB(for back turning), SG(for grooving), ST(for threading), SC(for parting off), SGB(for grooving and back turning)
- ▶ Convenient use of one holder to all inserts
- ▶ Offset "0" to all ISO type holders

▶ Insert code system (Multi utility type)

B : Back turning **G** : Grooving
C : Parting off **T** : Threading
GB : Grooving and back turning

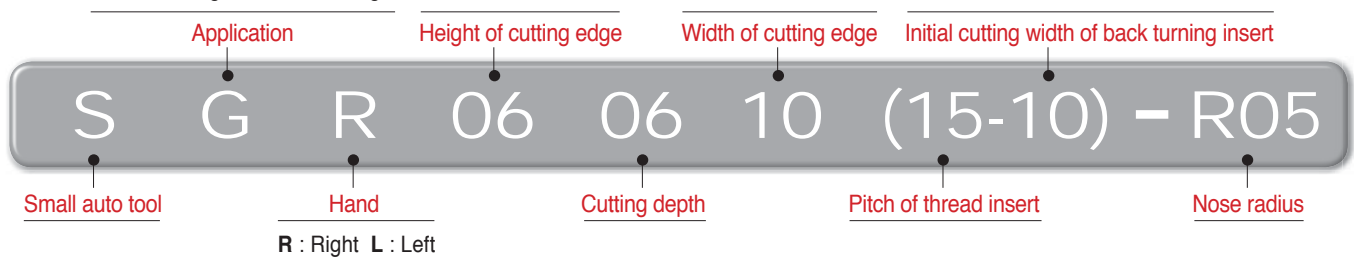

▶ Application example

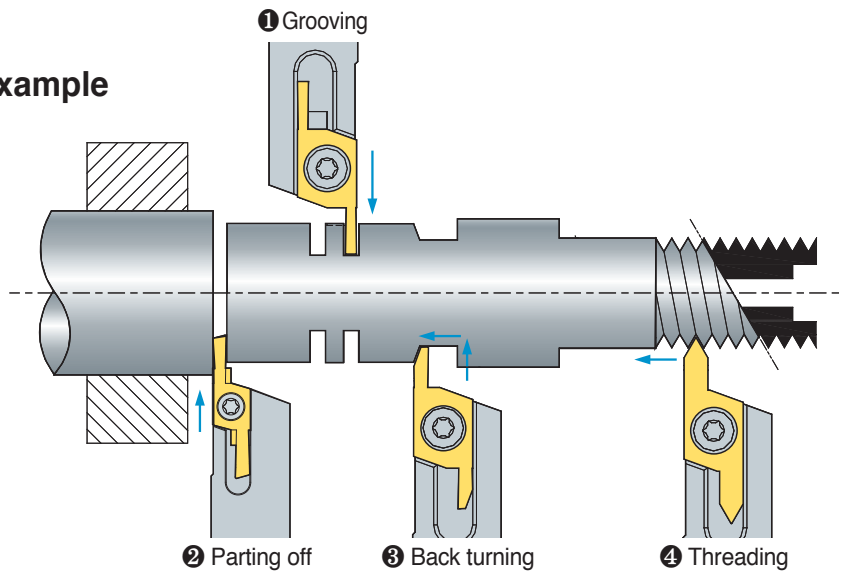

▶ Types of multifunctional insert

Possible to apply various types of blade inserts to one holder (Ex: All designations of 06 size inserts can be applied to one 06 size holder.)

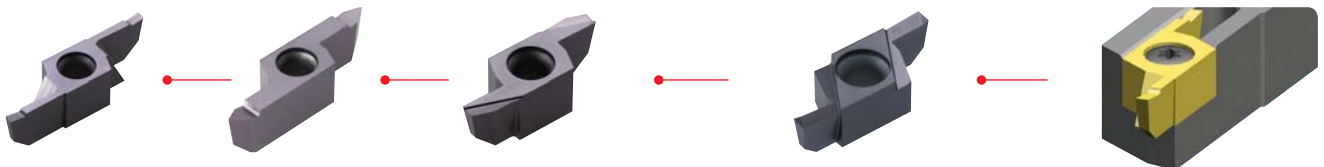

SG : Grooving

ST : Threading

SB : Back turning

SGB : Grooving and back turning

SC : Parting off

▶ Recommended cutting conditions

Workpiece	Turning		Grooving		Parting off		Back turning	
	Cutting speed, vc(m/min)	Feed, fn(mm/rev)	Cutting speed, vc(m/min)	Feed, fn(mm/rev)	Cutting speed, vc(m/min)	Feed, fn(mm/rev)	Cutting speed, vc(m/min)	Feed, fn(mm/rev)
Stainless steel	50 ~ 120	0.02 ~ 0.20	30 ~ 120	0.02 ~ 0.05	30 ~ 120	0.02 ~ 0.05	30 ~ 120	0.02 ~ 0.20
Carbon steel	50 ~ 150	0.01 ~ 0.25	50 ~ 150	0.02 ~ 0.08	50 ~ 150	0.01 ~ 0.08	50 ~ 150	0.01 ~ 0.25
Free cutting steel	30 ~ 150	0.02 ~ 0.25	30 ~ 150	0.02 ~ 0.08	30 ~ 150	0.01 ~ 0.08	30 ~ 150	0.01 ~ 0.25
Non ferrous metal	70 ~ 200	0.03 ~ 0.25	70 ~ 200	0.03 ~ 0.10	70 ~ 200	0.03 ~ 0.10	70 ~ 200	0.03 ~ 0.30



B Auto tools (For multi utility)

SXGNR/L



SBR, SGBR
SCR, STR, SGR

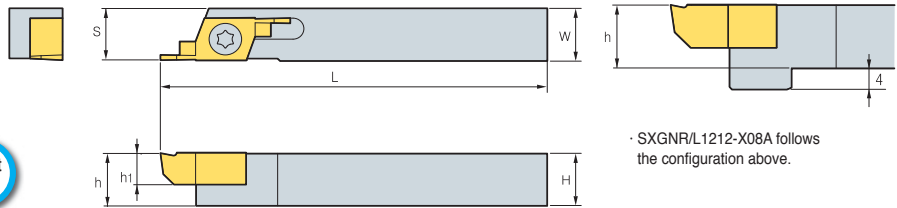

· SXGNR/L1212-X08A follows the configuration above.

· R type insert

(mm)

Designation	Stock		H	W	L	S	h	h ₁	Insert	Screw	Wrench
	R	L									
SXGNR/L 1010-X06A	●		10	10	125	10	10	6	S□R/L 06	FTNA 0408	TW 15P
	●		12	12	125	12	12	6			
	●		16	16	125	16	16	6			
	●		20	20	125	20	20	6			
SXGNR/L 1212-X08A	●		12	12	130	12	12	8	S□R/L 08	FTNA 0411	TW 15P
			16	16	130	16	16	8			
			20	20	130	20	20	8			
			20	20	130	20	20	8			

● : Stock item

▶ Insert

Application	Picture	Designation	Coated		Dimensions (mm)								Configuration	Feed direction
			PC9030		b ₁	b	W	L	r	h	T-MAX	ØD		
			R	L										
Back turning		SBR/L 060520-10-R00			1	2	8	22	0	6	5.5	-		
		060520-10-R05			1	2	8	22	0.05	6	5.5	-		
		060520-10-R10			1	2	8	22	0.1	6	5.5	-		
		060630-20-R00			2	3	8	24	0	6	6.5	-		
		060630-20-R05			2	3	8	24	0.05	6	6.5	-		
		060630-20-R10			2	3	8	24	0.1	6	6.5	-		
		080630-20-R00			2	3	8	23	0	8	6.5	-		
		080630-20-R05			2	3	8	23	0.05	8	6.5	-		
		080630-20-R10			2	3	8	23	0.1	8	6.5	-		
		080840-20-R00			2	4	8	27	0	8	8.5	-		
080840-20-R05			2	4	8	27	0.05	8	8.5	-				
080840-20-R10			2	4	8	27	0.1	8	8.5	-				
Parting off		SCR/L 060610-R00			-	1	8	24	0	6	-	11		
		060610-R05	●		-	1	8	24	0.05	6	-	11		
		060610-R10	●		-	1	8	24	0.1	6	-	11		
		060615-R00			-	1.5	8	24	0	6	-	11		
		060615-R05	●		-	1.5	8	24	0.05	6	-	11		
		060615-R10	●		-	1.5	8	24	0.1	6	-	11		
		060620-R00			-	2	8	24	0	6	-	11		
		060620-R05	●		-	2	8	24	0.05	6	-	11		
		060620-R10	●		-	2	8	24	0.1	6	-	11		
		081015-R00			-	1.5	8	31	0	8	-	18		
		081015-R05			-	1.5	8	31	0.05	8	-	18		
		081015-R10			-	1.5	8	31	0.1	8	-	18		
		081020-R00			-	2	8	31	0	8	-	18		
		081020-R05			-	2	8	31	0.05	8	-	18		
		081020-R10	●		-	2	8	31	0.1	8	-	18		
		081025-R00			-	2.5	8	31	0	8	-	18		
		081025-R05	●		-	2.5	8	31	0.05	8	-	18		
		081025-R10	●		-	2.5	8	31	0.1	8	-	18		
081030-R00			-	3	8	31	0	8	-	18				
081030-R05	●		-	3	8	31	0.05	8	-	18				
081030-R10			-	3	8	31	0.1	8	-	18				

● : Stock item

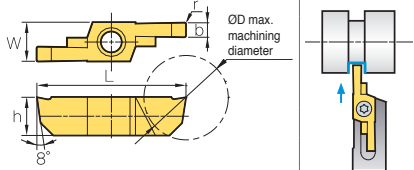
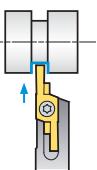
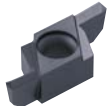
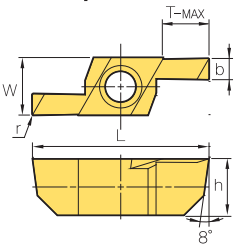
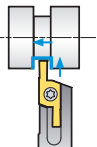
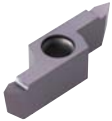
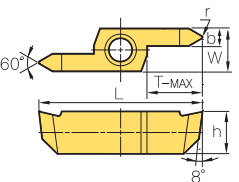
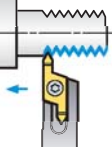

Insert

Application	Picture	Designation	Coated		Dimensions (mm)								Configuration	Feed direction
			PC9030		b	W	L	r	h	T-MAX	ØD	Pitch		
			R	L										
Grooving		SGR/L	060610-R00		1	8	24	0	6	-	11	-		
		060610-R05	●	1	8	24	0.05	6	-	11	-			
		060610-R10	●	1	8	24	0.1	6	-	11	-			
		060615-R00		1.5	8	24	0	6	-	11	-			
		060615-R05	●	1.5	8	24	0.05	6	-	11	-			
		060615-R10	●	1.5	8	24	0.1	6	-	11	-			
		060620-R00		2	8	24	0	6	-	11	-			
		060620-R05	●	2	8	24	0.05	6	-	11	-			
		060620-R10	●	2	8	24	0.1	6	-	11	-			
		081015-R00		1.5	8	31	0	8	-	18	-			
		081015-R05		1.5	8	31	0.05	8	-	18	-			
		081015-R10		1.5	8	31	0.1	8	-	18	-			
		081020-R00		2	8	31	0	8	-	18	-			
		081020-R05	●	2	8	31	0.05	8	-	18	-			
		081020-R10		2	8	31	0.1	8	-	18	-			
		081025-R00		2.5	8	31	0	8	-	18	-			
		081025-R05		2.5	8	31	0.05	8	-	18	-			
		081025-R10		2.5	8	31	0.1	8	-	18	-			
081030-R00		3	8	31	0	8	-	18	-					
081030-R05		3	8	31	0.05	8	-	18	-					
081030-R10		3	8	31	0.1	8	-	18	-					
Grooving and back turning		SGBR/L	0604520-R00		2	8	22	0	6	4.5	-	-		
		0604520-R05		2	8	22	0.05	6	4.5	-	-			
		0604520-R10		2	8	22	0.1	6	4.5	-	-			
		0604525-R00		2.5	8	22	0	6	4.5	-	-			
		0604525-R05		2.5	8	22	0.05	6	4.5	-	-			
		0604525-R10		2.5	8	22	0.1	6	4.5	-	-			
		0605530-R00		3	8	24	0	6	5.5	-	-			
		0605530-R05		3	8	24	0.05	6	5.5	-	-			
		0605530-R10		3	8	24	0.1	6	5.5	-	-			
		0805525-R00		2.5	8	24	0	8	5.5	-	-			
		0805525-R05		2.5	8	24	0.05	8	5.5	-	-			
		0805525-R10		2.5	8	24	0.1	8	5.5	-	-			
		0806530-R00		3	8	26	0	8	6.5	-	-			
		0806530-R05		3	8	26	0.05	8	6.5	-	-			
0806530-R10		3	8	26	0.1	8	6.5	-	-					
Threading		STR/L	06073215		3.2	8	25	0.06	6	7	-	0.5-1.5		
		06073230		3.2	8	25	0.19	6	7	-	1.5-3.0			
		08103215		3.2	8	31	0.06	8	10.5	-	0.5-1.5			
		08103230		3.2	8	31	0.19	8	10.5	-	1.5-3.0			

● : Stock item

B Auto tools (KGT/MGT type)

Auto tools (KGT/MGT type)

- ▶ Grooving insert for automatic lathes
- ▶ Exclusive holder for automatic lathes
- ▶ Economic double sided insert
- ▶ Strong clamping system secures stable machining and precision.
- ▶ A wide selection of chip breakers according to various cutting conditions such as low/high feed, continuous/interrupted machining, etc.

▶ Insert code system (KGT/MGT type)

KG	M	N	300	-	04	-	T
System code	Tolerance	Hand	Width of cutting edge		Corner nose radius of insert		Chip breaker
KG SYSTEM (KORLOY Grooving) MG SYSTEM (Multi Grooving)	M : Pressed class G : Ground class	N : Neutral R : Right L : Light I : Internal	2.0~8.0mm		0.2mm 0.3mm 0.4mm		L / R / T / LP / RP

▶ Holder code system (KGT/MGT type)

KG	E	H	R/L	1212	-	3	D25A
System code	Application	Holder type	Hand	Shank size	Cutting width		Max. cutting diameter
KG SYSTEM (KORLOY Grooving) MG SYSTEM (Multi Grooving)	E : External machining I : Internal machining	H : Horizontal type V : Vertical type U : Undercut type	R : Right L : Light	Height 12mm, width 12mm (For internal machining : Min. machining diameter)	2.0~3.0mm		Ø15~Ø32mm

▶ Chip breaker line-up

KGMN-L



- Sharp cutting edge
- For low feed machining
- For small diameter parts

KGMN-R



- Reinforced cutting edge
- For high feed machining
- For interrupted cutting

KGMN-T



- Sharp cutting edge
- Stronger chip control
- For turning and grooving

MGM(G)N-M



- Easier chip control by narrowing chip width with the use of chip breaker on rake surface center
- Smooth chip flow by small dots in external machining
- Available for both external machining and grooving

MGMN-G



- Specially designed chip breaker allows narrower chips to promote better chip flow with the use of center dots
- Exclusive chip breaker for grooving



KGEHR/L-D00A

Grooving, turning, parting off



KGGN KGMN KGMR/L

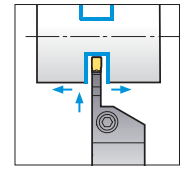
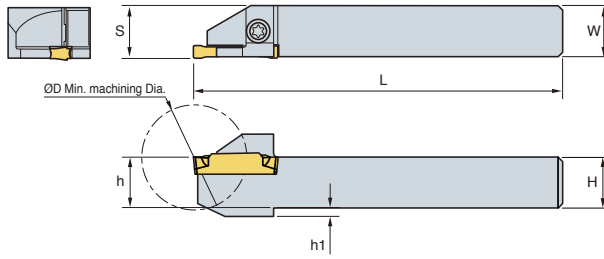

• R type insert
(mm)

Designation	Stock		H=(h)	W	L	S	h ₁	ØD Max	Insert	Screw	Wrench
	R	L									
KGEHR/L	●		10	10	125	10.2	2	20	KGMN200-□-□ KGMR/L200-□-□ KRMN200-C	ETNA0412	TW15L
	●		12	12	125	12.2	2	25			
	●		14	14	125	14.2	-	25			
	●		16	16	125	16.2	-	32			
	●		12	12	125	12.4	2	25	KGMN300-□-□ KGMR/L300-□-□ KRMN300-C KGGN□-□-□		
	●		16	16	125	16.4	-	32			
	●										

● : Stock item

▶ KGT Insert

Application	Picture	Designation	Coated					Dimensions (mm)					Configuration
			NC3220	NC3225	NC5330	PC5300	PC9030	b	r	l	d	α°	
Grooving		KGMRN 200-02-L	●	●	●	●	●	2.0	0.2	20	1.7	-	
		300-02-L	●	●	●	●	●	3.0	0.2	20	2.3	-	
Grooving, Parting off		KGMRN 200-02-R	●	●	●	●	●	2.0	0.2	20	1.7	-	
		300-02-R	●	●	●	●	●	3.0	0.2	20	2.3	-	
Grooving-turning		KGMRN 200-02-T	●	●	●	●	●	2.0	0.2	20	1.7	-	
		300-02-T	●	●	●	●	●	3.0	0.2	20	2.3	-	
		300-04-T	●	●	●	●	●	3.0	0.4	20	2.3	-	
Parting off (left handed)		KGMR 200-6D-LP			●	●		2.0	0.2	20	-	6	
		200-15D-LP			●	●		2.0	0.2	20	-	15	
		300-6D-LP			●	●		3.0	0.2	20	-	6	
		300-15D-LP			●	●		3.0	0.2	20	-	15	
Parting off (right handed)		KGMR 200-6D-RP			●	●		2.0	0.2	20	-	6	
		200-15D-RP			●	●		2.0	0.2	20	-	15	
		300-6D-RP			●	●		3.0	0.2	20	-	6	
		300-15D-RP			●	●		3.0	0.2	20	-	15	

● : Stock item



B Auto tools (MGT type)

MGEHR/L



MGMN

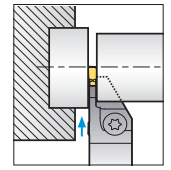
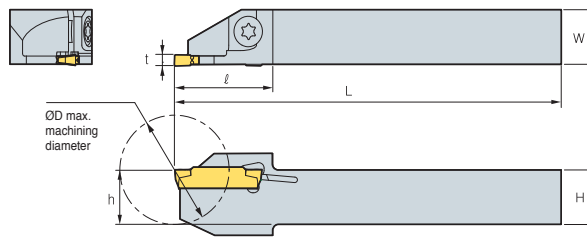

• R type insert
(mm)

Designation	Stock		ØD	H=h	W	L	ℓ	t	Insert	Screw	Wrench
	R	L									
MGEHR/L 1010-X15A	●		20	10	10	125	18	1.5	MGMN150-G	ETNA 0412	TW 15L
	●		25	12	12	125	19.5	1.5			
1010-X20A			20	10	10	125	18	2	MGMN200-M MGMN200-G	ETNA 0412	TW 15L
1212-X20A			25	12	12	125	19.5	2			
1616-X20A			32	16	16	125	25	2	MGMN250-M MGMN250-G	ETNA 0412	TW 15L
1010-X25A			20	10	10	125	20	2.5			
1212-X25A			25	12	12	125	20	2.5			
1616-X25A			32	16	16	125	25	2.5			

● : Stock item

▶ MGT Insert

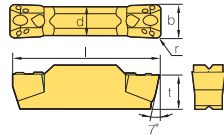
Application	Picture	Designation	Cermet		Coated				Uncoated			Dimensions (mm)					Configuration	
			CN2000	CN20	NC3120	NC3220	NC5330	NC3030	PC5300	PC9030	H01	G10E	A30	b	r	l		d
Grooving / Parting off	MGMN 	MGMN 150-G			●	●	●	●	●				1.5	0.15	16	1.2	3.5	
		200-G			●	●	●	●	●				2	0.2	16	1.6	3.5	
		200-M			●	●	●	●	●	●			2	0.2	16	1.6	3.5	
		250-G				●	●	●	●	●			2.5	0.2	18.5	2	3.85	
		250-M			●	●	●	●	●	●			2.5	0.2	18.5	2	3.85	

● : Stock item

