

Contact Points



18-35 mm / .7-1.4"



35-60 mm / 1.4-2.5"



50-150 mm / 2.0-6.0"



100-160 mm / 4.0-6.5"



160-250 mm / 6.5-10.0"

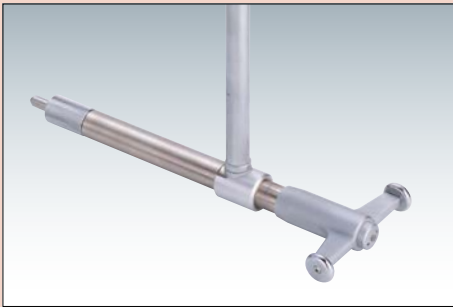

250-400 mm / 10.0-16.0"

Specifications

Inch							
Code No.	Range	Measuring force	Content of set			Probing depth	
			Bore gauge	Dial indicator	Anvils		
Graduation .0001"							
511-751	.7-1.4"	4 N or less	511-731	2923SB-10	9 pcs.	4"	
511-752	1.4-2.5"		511-732		6 pcs.		
511-753	2.0-6.0"	5 N or less	511-733		11 pcs.	6"	
511-754	4.0-6.5"		511-734		13 pcs.		
511-755	6.5-10.0"	6 N or less	511-735		6 pcs.	10"	
511-756	10.0-16.0"		511-736		5 pcs.		
Graduation .0005"							
511-741	.7-1.4"	4 N or less	511-731	2922SB	9 pcs.	4"	
511-742	1.4-2.5"		511-732		6 pcs.		
511-743	2.0-6.0"	5 N or less	511-733		11 pcs.	6"	
511-744	4.0-6.5"		511-734		13 pcs.		
511-745	6.5-10.0"	6 N or less	511-735		6 pcs.	10"	
511-746	10.0-16.0"		511-736		5 pcs.		
Bore gauge sets							
Code No.	Range	Measuring head units	Dial indicator				
511-931	.7-6.0"	511-731	2922SB				
511-932		511-732	2923SB-10				
511-935-10		511-733	543-312B				

Dimensions

