

Contact Points



60-100 mm / 2.4-4"



100-160 mm / 4-6.4"



150-250 mm / 6-10"

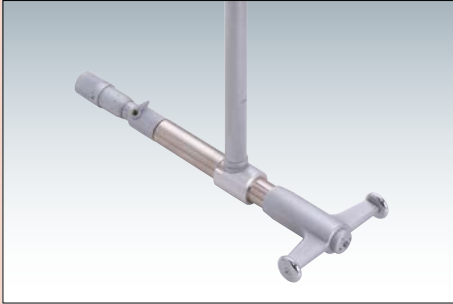

250-400 mm / 10-16"



400-600 mm / 16-24"

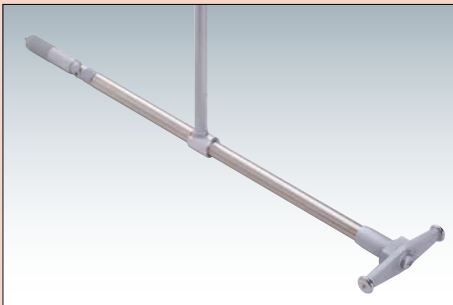

600-800 mm / 24-32"

Specifications

Metric							
Code No.	Range	Measuring force	Content of set			Probing depth	
			Bore gauge	Dial indicator	Sub-anvils		
Graduation 0.001 mm							
511-823	60-100 mm	5 N or less	511-803	2109SB-10	2 pcs.	150 mm	
511-824	100-160 mm		511-804		3 pcs.		
511-825	150-250 mm	6 N or less	511-805		4 pcs.		250 mm
511-826	250-400 mm		511-806		3 pcs.		
511-827	400-600 mm		511-807		2 pcs.		
511-828	600-800 mm		511-808		2 pcs.		
Graduation 0.01 mm							
511-813	60-100 mm	5 N or less	511-803	2046SB	2 pcs.	150 mm	
511-814	100-160 mm		511-804		3 pcs.		
511-815	150-250 mm	6 N or less	511-805		4 pcs.		250 mm
511-816	250-400 mm		511-806		3 pcs.		
511-817	400-600 mm		511-807		2 pcs.		
511-818	600-800 mm		511-808		2 pcs.		

Inch							
Code No.	Range	Measuring force	Content of set			Probing depth	
			Bore gauge	Dial indicator	Sub-anvils		
Graduation .0001"							
511-853	2.4-4.0"	5 N or less	511-833	2923SB-10	2 pcs.	4"	
511-854	4.0-6.4"		511-834		3 pcs.		
511-855	6.0-10.0"	6 N or less	511-835		4 pcs.		6"
511-856	10.0-16.0"		511-836		3 pcs.		
511-857	16.0-24.0"		511-837		2 pcs.		
511-858	24.0-32.0"		511-838		2 pcs.	10"	
Graduation .0005"							
511-843	2.4-4.0"	5 N or less	511-833	2922SB	2 pcs.	4"	
511-844	4.0-6.4"		511-834		3 pcs.		
511-845	6.0-10.0"	6 N or less	511-835		4 pcs.		6"
511-846	10.0-16.0"		511-836		3 pcs.		
511-847	16.0-24.0"		511-837		2 pcs.		
511-848	24.0-32.0"		511-838		2 pcs.	10"	

Dimensions

