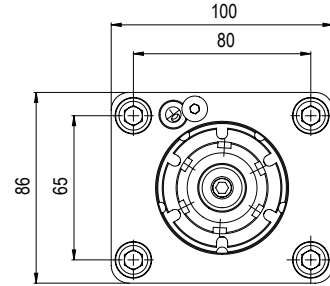
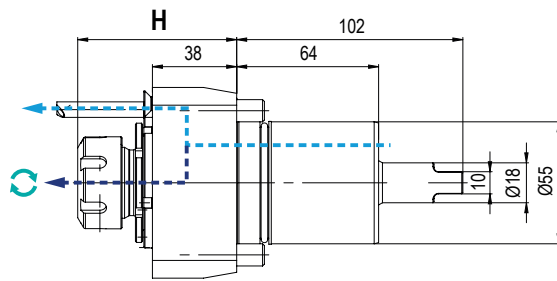

MODELLI DI TORNIO COMPATIBILI
 COMPATIBLE LATHE TYPES

OKUMA

Vedi pagine compatibilità 5.8 / 5.9 - See compatibility pages 5.8 / 5.9

NEW

Code	Output	Int Cool.	H	Nm	Rpm	kw	
99.OK.A01	ER-25	NO	71,7	40	8.000	8	
99.OK.A02	ER-25	✓	71,7	40	8.000	8	
99.OK.A14	ER-32	NO	78	70	6.000	6	
99.OK.A15	ER-32	✓	78	70	6.000	6	

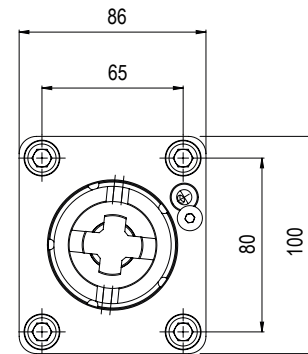
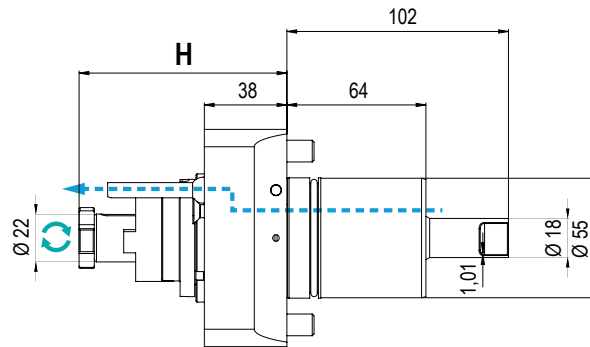
NEW

Code	Output	Int Cool.	H	Nm	Rpm	kw	
99.OK.A16	PF-20	NO	96	60	6.000	10	
99.OK.A17	PF-27	NO	97	60	6.000	10	