



Referans Nr.		m	h		s	s1	e1	d	sw	L	e	b	c	Sıkma Kuvveti Clamping Force Kgf	
			min	max											
1120-014 T	14	M12	0	50	12-66	25	100	M14	8	104	35.5	38	13	1600	1700
1120-016 T	16	M12	0	50	12-66	25	100	M14	8	104	35.5	38	13	1600	1700
1120-018 T	18	M12	0	50	12-66	25	100	M14	8	104	35.5	38	13	1600	1700
1130-014 T	14	M12	0	60	15-83	30	113	M18	10	130	39	48	17.5	2000	3040
1130-016 T	16	M12	0	60	15-83	30	113	M18	10	130	39	48	17.5	2000	3055
1130-018 T	18	M12	0	60	15-83	30	113	M18	10	130	39	48	17.5	2000	3085
1130-020 T	20	M12	0	60	15-83	30	113	M18	10	130	39	48	17.5	2000	3135
1130-022 T	22	M12	0	60	15-83	30	113	M18	10	130	39	48	17.5	2000	3150

Ürün Nr. 1120-1130 Kızaklı Kombine Bağlama Pabucu (K.K.S.P)

• **1120 Nr. K.K.S.P** (a) 14-18 "T" kanalda M12 imbus civata DIN 508 "T" pabuçla kullanılır. Parça yükseklik sıkma aralığı 0-50 mm ileri-geri hareket mesafesi 54mm'dir. Sıkma Kuvveti 1600 kgf.

• **1130 Nr. K.K.S.P** (a) 14-22 "T" kanalda M12 imbus civata DIN 508 "T" pabuçla kullanılır. Parça yükseklik sıkma aralığı 0-60 mm ileri-geri hareket mesafesi 68mm'dir. Sıkma Kuvveti 2000 kgf.

Product Nr. 1120-1130 Combined Sliding Clamp (K.K.S.P)

• **1120 Nr. K.K.S.P** (a) 14-18 is used in "T" Slot and M12 imbus bolt is used with DIN 508 "T" clamp. Height clamping gap of the piece is 0-50mm, back-and- forth movement distance is 54mm. Clamping force is 1600 kgf.

• **1130 Nr. K.K.S.P** (a) 14-22 is used in "T" Slot and M12 imbus bolt is used with DIN 508 "T" clamp. Height clamping gap of the piece is 0-60mm, back-and- forth movement distance is 68mm. Clamping force is 2000 kgf.

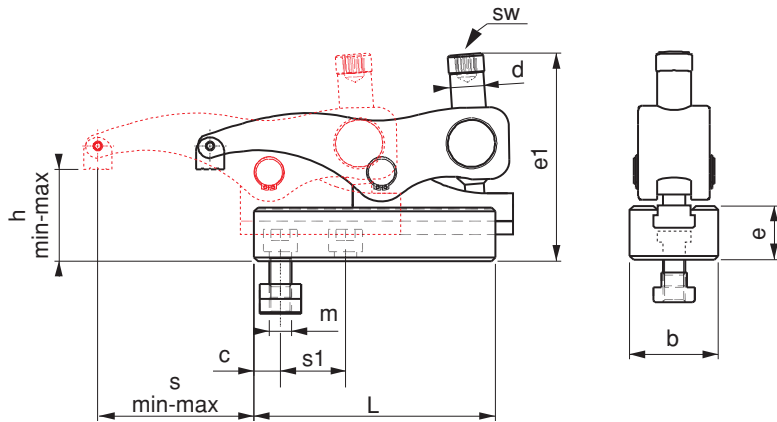

UYGULAMA;

- 1- Alt kızağı iş parçasına uygun şekle getir sabitle
- 2- Üst gövdeyi kızağa sür, istenilen pozisyona getir
- 3- Pabuç imbus civatasıyla iş parçasını sabitle
- 4- Parça işlenmek için hazır

APPLICATION;

- 1- Slide cradle is brought to suitable form with the work piece and then it is fixed
- 2- Upper body is driven to the slide and it is brought to desired position
- 3- Work piece is fixed with the imbus bolt of the clamp
- 4- Then the work piece becomes ready to be machined.



Kullanım Alanı

Enjeksiyon makineleri presler, freze tezgahları, matkap tezgahları ve çeşitli sanayi makineleri

Area of Use

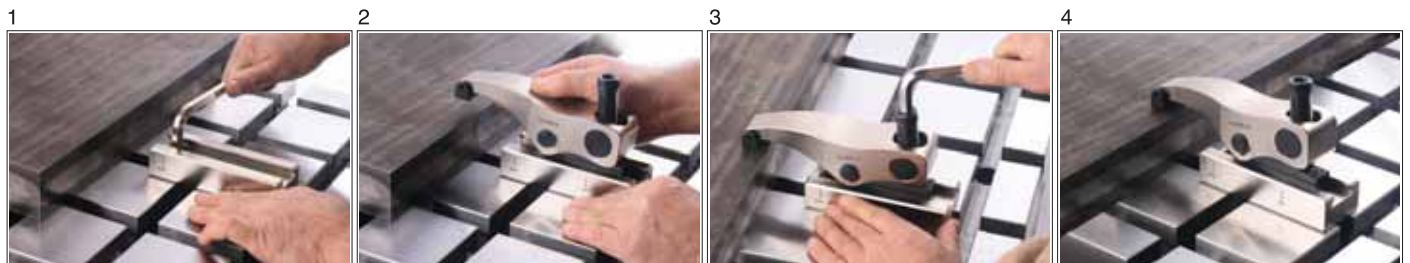
Injection Machines, Presses, Milling Machines, Drilling Machines and various Industrial Machines



Referans Nr.		m	h		s	s1	e1	d	sw	L	e	b	c	Sıkma Kuvveti Clamping Force Kg		
			min	max												
1150-118 T	18	M16	0	65	18-96	35	125	M20	12	140	43	55	19.5	2500	4410	
1150-120 T	20	M16	0	65	18-96	35	125	M20	12	140	43	55	19.5	2500	4460	
1150-122 T	22	M16	0	65	18-96	35	125	M20	12	140	43	55	19.5	2500	4515	
1150-124 T	24	M16	0	65	18-96	35	125	M20	12	140	43	55	19.5	2500	4620	
1150-128 T	28	M16	0	65	18-96	35	125	M20	12	140	43	55	19.5	2500	4725	
																
1160-222 T	22	M20	20	80	17-92	41.5	175	M24	12	24	178	55	74	24	5500	9030
1160-224 T	24	M20	20	80	17-92	41.5	175	M24	12	24	178	55	74	24	5500	9120
1160-228 T	28	M24	20	80	17-92	41.5	175	M24	12	24	178	55	74	24	5500	9180
1160-236 T	36	M24	20	80	17-92	41.5	175	M24	12	24	178	55	74	24	5500	9600

Ürün Nr. 1150-1160 Kızaklı Kombine Bağlama Pabucu (K.K.S.P)

• **1150 Nr. K.K.S.P** (a) 18-28 "T" kanalda M16 imbus civata DIN 508 "T" pabuçla kullanılır. Parça yükseklik sıkma aralığı 0-65mm ileri-geri hareket mesafesi 78mm'dir. Sıkma Kuvveti 2500 kgf.

• **1160 Nr. K.K.S.P** (a) 22-36 "T" kanalda M20-M24 imbus civata DIN 508 "T" pabuçla kullanılır. Parça yükseklik sıkma aralığı 20-80mm ileri-geri hareket mesafesi 73mm'dir. Sıkma Kuvveti 5500 kgf.

Product Nr. 1150-1160 Combined Sliding Clamp (K.K.S.P)

• **1150 Nr. K.K.S.P** (a) 18-28 is used in "T" Slot and M16 imbus bolt is used with DIN 508 "T" clamp. Height clamping gap of the piece is 0-65mm, back-and-forth movement distance is 78mm. Clamping force is 2500 kgf.

• **1160 Nr. K.K.S.P** (a) 22-36 is used in "T" Slot and M20-M24 imbus bolt is used with DIN 508 "T" clamp. Height clamping gap of the piece is 20-80mm, back-and-forth movement distance is 73mm. Clamping force is 5500 kgf.

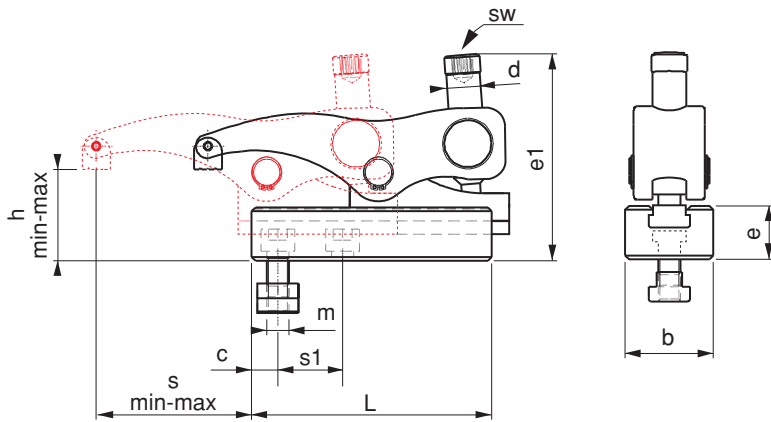

UYGULAMA;

- 1- Alt kızağı iş parçasına uygun şekle getir sabitle
- 2- Üst gövdeyi kızağa sür, istenilen pozisyona getir
- 3- Pabuç imbus civatasıyla iş parçasını sabitle
- 4- Parça işlenmek için hazır

APPLICATION;

- 1- Slide cradle is brought to suitable form with the work piece and then it is fixed
- 2- Upper body is driven to the slide and it is brought to desired position
- 3- Work piece is fixed with the imbus bolt of the clamp
- 4- Then the work piece becomes ready to be machined.

Kullanım Alanı

Enjeksiyon makineleri presler, freze tezgahları, matkap tezgahları ve çeşitli sanayi makineleri

Area of Use

Injection Machines, Presses, Milling Machines, Drilling Machines and various Industrial Machines

